

## Information Transfer Exercise on Landslide Conducted

The information transfer exercise on landslide was conducted by NBRO, DMC and selected local level organizations in 1<sup>st</sup> August.

The aim of the exercise is to discuss, confirm and familiarize the actions to take for the information transfer. Furthermore, it is purposed to reflect the confirmed actions to "Preparedness and Response Plan"(PRP) or "Standard Operation Procedure"(SOP) etc.

### In This Issue :

- Information Transfer Exercise on Landslide
- Counterpart Meeting
- Joint Coordinating Committee

## Information Transfer Exercise on Landslide

### Schedule and Participating Organizations

Participating organizations supported by DiMCEP team conducted the information transfer exercise on landslide under the following schedule.

July	Middle of July	Interview Survey to DDMCU	
	26th	Preparatory Meeting (DMC and NBRO)	
	27th- 29th	Explanation to GA, DDMCU, DS, GN	
August	1st	AM	Explanation to DMC
		14:00	Exercise
	5th, 10:30-		Evaluation Meeting (DMC, NBRO, DDMCU)

4 districts and, 1 DSD and GND of each district shown below were selected as targets.

GA/DDMCU	DSD	GND
Badulla	Haliela	Godegama
Kegalle	Kegalle	Bogala
Rathnapura	Rathnapura	Mahawala
Nuwara Eliya	Walapane	Alakolawewa

### Preparatory Meeting

The pre-meeting was held in 26th July. DiMCEP team explained the outline of the information transfer exercise. DMC and NBRO officers shared the overview of the exercise.

### Explanation to GA, DDMCU, DS, GN

From 27th to 29th July, DiMCEP team visited target DDMCU in order to explain about the exercise to DDMCU coordinators and related officers. At the same time, DiMCEP team interviewed about the reality and issues of information transfer at local level.

### The Outline of the Exercise

At the exercise, the 2 warning messages, level 1 and level 2 messages issued by NBRO were transferred to GN via DMC, DDMCU. The information flow for transferring level 2 message is shown below.

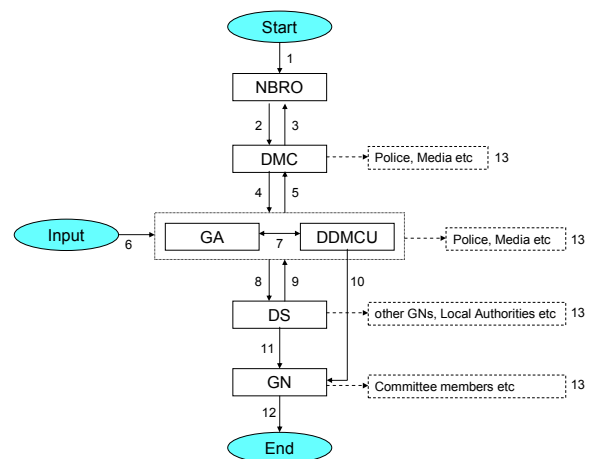

Level 2 message is "get ready to evacuate". At the exercise, local information from GN (rock fall etc) was also given to the DDMCU coordinators. Based on the level 2 message and the local information, GA and DDMCU discuss and make appropriate instructions to DS and GND.



Receiving the information (Kegalle)

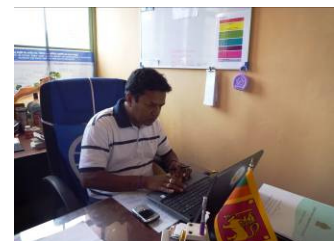

Issuing the warning document (Nuwara Eliya)



Discussion between DDMCU and DS (Rathnapura)

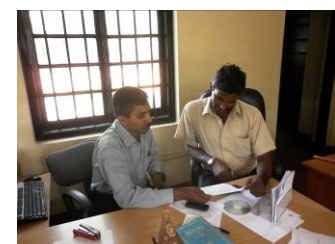

Sharing the information (Badulla)

## Evaluation Meeting

The evaluation meeting of the exercise was held in August 5th. Following 4 items are discussed based on the result of the exercise.

- How to transfer without any omitting or error?
- To which organizations should the information be transferred?
- How to judge and select the local area to be affected?
- How to handle and take countermeasures to the field information from communities?

The periodical information transfer exercises, Disaster Imagination Game (DIG) and the continuous discussions were proposed. Additionally, it is suggested that the result of the exercise and discussion is reflected to PRP or SOP.

DiMCEP team requested DMC to join the preparatory meeting at the first level, to participate the exercise as evaluators and to understand the necessity of providing the minimum equipments for information transfer such as fax to local level organizations.

## **Counterpart Meeting**

To share the information on the progress of the project, a series of CP meeting was held.

### The 2<sup>nd</sup> Counterpart Meeting

The 2<sup>nd</sup> counterpart Meeting was held at conference room of DMC in June 22nd.

The presentations on Activity 1-4 of Output 1, Disaster Impact Assessment (DIA) and the point of review of Preparedness and Response Plan were made.

### The 3<sup>rd</sup> Counterpart Meeting

In July 6th, the 3<sup>rd</sup> counterpart meeting was held at meeting room of DMC. A presentation on Output 3, landslide monitoring was made by NBRO and DiMCEP team. And a presentation on the questionnaire survey on tsunami watch was also made.



*The 2<sup>nd</sup> Counterpart Meeting*



*The 3<sup>rd</sup> Counterpart Meeting*

### The 4<sup>th</sup> Counterpart Meeting

The 4<sup>th</sup> counterpart Meeting was held in July 25th. The progress of Output 2, Automatic Weather Station (AWS) and Numerical Weather Prediction (NWP) systems relevant to Department of Meteorology was reported. The participants discussed lively on the data sharing of AWS.

A presentation on the investment effect for disaster

management was also made.

## **Joint Coordinating Committee**

Joint Coordinating Committee (JCC) was held at conference room of DMC in August 4<sup>th</sup>, chaired by Ms. S. M. Mohamed, Secretary of Ministry of Disaster Management.

### Objectives

JCC is the annual occasion for counterparts, JICA and DiMCEP team to gather and discuss on the project.

This time, JCC was held for the objectives to explain, discuss and confirm the progress and work plan of the DiMCEP (Item 1), the proposal of additional activity (Item 2), and the proposal of modification of the Project Design Matrix (PDM) (Item 3).

### Contents of Discussion

The contents of discussion on each item are as follows:

#### Item 1

On item 1, the progress and work plan of the DiMCEP were explained, discussed and confirmed. Department of Irrigation (DOI) requested to be included as a target of the capacity enhancement of the project.

DG of DMC expressed the importance of the data sharing on rainfall and water level.

#### Item 2

JICA Sri Lanka office explained the idea of the additional activity to review the district level PRP based on the recommendation of the short term expert team which was dispatched in April, May and June, 2011.

#### Item 3

Original PDM was modified, and PDM (Ver.2) was prepared based on the proposal by both sides.



*The 4<sup>th</sup> Counterpart Meeting*



*Joint Coordinating Committee*

## **Next Issue**

- Automatic Weather Station (AWS) / Numerical Weather Prediction (NWP)
- Activity for Output 5

DiMCEP Newsletter No.2 (August 2011)  
JICA Expert Team  
on Disaster Management Capacity Enhancement Project  
Adaptable to Climate Change  
c/o Disaster Management Centre, 2nd Floor,  
No.498, R.A.de Mel Mawatha, Colombo-3, Sri Lanka  
Tel: +94-(0)112-136-210 e-mail: jica.dmc@gmail.com