

year of operation (2018) the Fixed cost Component is expected to be high i.e. about 72% of total TAC, however, it will progressively decline over time as traffic volumes grow and 25 years later the ratio of Fixed Cost to Variable Cost is projected to be in case of the Eastern Corridor 26:74 and Western Corridor 49:51. The TAC is planned to be fixed in such a manner that DFCCIL neither suffers losses nor makes windfall profits.

Another interesting aspect is the relationship between the Track Access Charges paid to DFCCIL and the apportioned revenue to the length traversed over DFCCIL lines. In a scenario when freight tariff is assumed to grow at 1% the TAC is only 26% of the apportioned revenue in the first year (2018) for both corridors combined and increases to 34% in the 25<sup>th</sup> year and 50% in the 50<sup>th</sup> year. The increase is because the costs of maintaining the system are assumed to grow at 6% annually whereas tariff only grows at 1%. However what the analysis in the Business plan reveals is that the project is sustainable over the long run despite a relatively small % age of the freight revenue being assigned to the DFCCIL in the form of Track Access Charges. Profit after Tax is forecast to be Rs 363 Crores in 2018 growing to Rs 572 Crores in 25 years. This reflects the efficiency that will be brought in by DFCCIL in Operations and Maintenance through increase in mechanization, reduced manpower norms, induction of new technology, systems etc.

### 3.6.8 The Dedicated Freight Corridor & The High Speed Railway Corridor –Some Common Objectives

Both DFC and HSR Corridor proposals highlight the endeavour of IR to rapidly create rail transport capacity for both freight and passenger traffic, induct state of the art technology, improve quality of service and increase its market share in the transport sector. IR is already the fourth largest freight carrying railway system in the world transporting over a billion tonnes of originating freight traffic (1007 Million tonnes / 645 Billion NTKMs in 2012-13) and the largest passenger carrying system in the world transporting in terms of Passenger Kilometres (8640 Million Passengers / 1117 Billion Pass. Kms. in 2012-13). Although in the last 60 years or so there has not been very modest growth in route kilometres and various input indicators there has been very significant growth in output. This has been possible by periodical up-gradation of technology and adopting operational strategies to optimize asset utilisation. In the 61 years between 1950-51 and 2011-12 whereas the Index for growth of various inputs e.g. Route Kilometres increased from 100 to 121, Wagon Capacity from 100 to 311, Passenger Coaches from 100 to 356, Tractive Effort of Locomotives from 100 to 372 the actual Traffic Output grew from 100 to 1516 in terms of Net Tonne Kilometres and 100 to 1505 in terms of Non-Suburban Passenger Kilometres. This phenomenal growth in output against relatively modest investment based inputs could only be achieved by steady induction of new technology and adopting innovative operational strategies. However, a stage has been reached when incremental improvement may not be adequate and large investments in expanding capacity and inducting the latest technology have become essential to keep pace with the India's anticipated economic growth. There is, therefore, a degree of similarity in the objectives that DFC and HSR Corridors as brought out in the following paragraphs.

The two major developments that have taken place over the last half century or in railway transportation have been Heavy Haul / Long Haul Transportation in case of Freight Transport and HSR in case of passenger transportation. Both these areas require specialized technology and dedicated rail corridors. IR had missed out on these developments and is therefore keen to acquire and develop these technologies. In case of freight therefore a conscious decision has been taken to adopt the 25 tonne axle load with the potential to go up to 32.5 tonne in future and to introduce long haul operations by increasing train lengths to twice the present level and with trailing loads of 15000 tonnes. In case of Passenger transport speed is critical for competing with both air transport and road. IR last increased the Maximum Permissible speed of its trains to 130 km/h in the late 1960's on the New Delhi to Howrah and New Delhi to Mumbai Central Routes for Rajdhani Express trains. Since then there has been a marginal increase speed to 150 km/h between New Delhi & Agra as a trial measure. There is therefore an urgent need being felt on Indian Railways to introduce higher speeds on the system in terms of Semi High Speed i.e. 160 to 200 km/h on existing corridors and new HSR Corridors with speeds between 300 to 350 km/h.

During the last few years there has been growing concern for the environment. The World over a conscious effort is being made to reduce the emission of Green House Gases a major component of which is Carbon Dioxide. According to the International Energy Agency (CO<sub>2</sub> Emissions from Fuel Combustion *Highlights* - 2013 Edition) India is the third largest contributor to CO<sub>2</sub> emissions in the world behind China and the United States of America and emits more than 5% of global emissions. Emissions grew by about 3 times between 1990 and 2011. 52% of the emissions were contributed by the power generation sector. Against

total emissions from fuel combustion of 1745.1 million tonnes of CO<sub>2</sub> the share of Transport is 169.9 Million Tonnes or 9.73%. Out of 169.9 Million Tonnes contributed by the Transport Sector the share of the Road sector is 154.1 million tonnes or 90% of the total CO<sub>2</sub> emissions of the Transport sector. The share of rail, shipping and aviation put together is therefore extremely small i.e. about 1% of the total CO<sub>2</sub> emissions of the country. The Government, therefore, is extremely keen promoting railway development and Railways increasing their market share in both freight and passenger segments on environmental considerations. According to a 'Green House Gas Emission Reduction Analysis for the DFC' conducted by Ernst & Young there would be a saving of 457 million tonnes of CO<sub>2</sub> emissions over 30 years. In case of HSR the UIC estimates CO<sub>2</sub> emissions in case of HSR, 100 passenger kilometres generate 4 Kg of CO<sub>2</sub>, Cars 14 Kg and aeroplanes 17 Kg. With regards energy efficiency the passenger kilometres carried per Unit (1 Kwh) is 170 in case of HSR, 54 in case of bus, 39 for cars and 20 for aircraft. HSR benefits also accrue in terms of efficiency in land use and in imposing external costs on society.

DFC experience of implementing two DFC projects also provides useful learning for the implementation of HSR Corridor once a decision is taken for implementation. This is applicable in case establishing new Standards for schedule of dimensions, construction standards for civil structures, signalling and telecommunication and overhead electrification as well as for rolling stock. There is also valuable experience in terms of land acquisition procedures, contract strategy, contract packaging and procurement procedures.

A major area where HSR Corridor will need to differ from DFC is in its Business Plan Model. In case of DFC, IR shall be collecting the freight as per its tariff from the consignor and will only pay a relatively small component to DFCCIL as Track Access Charge. This is because traffic volumes will be very high from the beginning and will be based on IR tariff which is high by global standards. The margins in Passenger Business are much lower than in Freight, therefore, in case of HSR the Business Model will need to be different and various options for generating non rail based revenue may need to be explored such as development of office and shopping space at Railway Stations or real estate development in the vicinity of stations.

#### REFERENCES

- Preliminary Engineering cum Traffic Study – Western Freight Corridor, RITES, January 2007
- Preliminary Engineering cum Traffic Study – Eastern Freight Corridor, RITES, January 2007
- Business Plan for DFCCIL, 2012 Draft Version XIV, Dedicated Freight Corridor Corporation of India Limited
- Data on DFCCIL Website
- Twelfth Five Year Plan (2012-2017), Volume II, Planning Commission

### 3.7 Plan for Semi High Speed Train on India Railways

#### 3.7.1 The Quest for Speed

Since time immemorial there has been an urge in all societies to improve mobility. This is why man progressed from a walking individual to taming animals for personal and goods transport, these included horses, donkeys, oxen and elephants. The invention of the 'wheel' came as a fundamental contribution to land transportation as it facilitated longer journeys in carts and carriages and subsequently facilitated railway systems and motorized transport. This along with water transport in boats and sail ships led to the spread of civilization to the far corners of the earth. The Industrial Revolution was based on utilizing the power of the steam engine. The development in the early nineteenth century of the Steam locomotive and the rolling of steel wheel on steel rail transformed surface transport for all time to come. Ever since then there has been an endeavour to constantly improve the speed of rail transport. For a major portion of the nineteenth and early twentieth century rail was the premier mode of transport. During the period railway networks expanded across most continents. With the invention of the fuel combustion engine and the automobile technology there was competition from the road sector after the development of massive highway networks, the world over, particularly, in the mid and latter half of the twentieth century. The development of air travel for long distance passenger journeys also impacted the primacy of rail. In all modes there has been a continuous effort to increase speeds and reduce journey times. With rapid technological advances the results achieved have also been remarkable. In case of air travel the Concorde became the First Aircraft to cross the sound barrier, more to prove a point, in long distance travel although the experience was short lived on viability and safety criteria. For air travel the optimum speed is presently considered to be about 900-950 Kmph. In case of road transport also speed has been a vital criteria, however, other than for individual speed records the potential for very high speeds beyond 120 Kmph or so in personal car based regular road transportation has serious constraints particularly related to safety. Therefore 120 to 140 Kmph is perhaps an optimal speed for automobile transportation.

#### 3.7.2 Progress of Speed in Rail Transport – Global Experience

Ever since the invention of the Steam Locomotive there has been the effort to improve on speed and at regular intervals new speed records have been established. This applies to steam traction, diesel and electric traction as well. The setting of rail speed records has been followed by increase in commercial speed of trains. What is interesting to note is that even as early as the beginning of the 20<sup>th</sup> Century remarkable absolute speed records were being established in rail transport as may be seen in the Table 3.7-1. A representative sample is indicated for all three types of traction.

**Table 3.7-1 Rail Speed Records Established by Different Modes of Traction for Selected Years**

YEAR	COUNTRY	SECTION	SPEED KMPH	TRACTION	LOCOMOTIVE/TRAIN
1825	BRITAIN	STOCKTON TO DARLINGTON	24	STEAM	STEPHENSON'S LOCOMOTION NO 1
1830	BRITAIN	MANCHESTER – LIVERPOOL	48	STEAM	STEPHENSON'S ROCKET
1848	USA	BOSTON – LAWRENCE	96.5	STEAM	BOSTON & MAINE 'ANTELOPE'
1907	GERMANY	MUNICH – AUGSBURG	154.5	STEAM	BAYERISCHEN S 2/6 #3201
1934	BRITAIN	GRANTHAM – PETERBOROUGH	161	STEAM	A1#4472 'FLYING SCOTSMAN'
1935	USA	MILWAUKEE – NEW LISBON	181	STEAM	CLASS A Nr.2 ATLANTIC 'HIAWATHA'
1938	BRITAIN	GRANTHAM – PETERBOROUGH	202.8	STEAM	A4 #4468 'MALLARD'
1934	USA	DENVER – LINCOLN	181	DIESEL	BUDD 'PIONEER ZEPHYR'
1939	GERMANY	HAMBURG – BERLIN	215	DIESEL	LINKE-HOFMANN SVT 137 155
1972	SPAIN	AZUQUECA – GUADALAJARA	222	DIESEL	TALGO III 353 005
1987	BRITAIN	DARLINGTON – YORK	238.9	DIESEL	HST INTERCITY 125 CLASS43
1997	RUSSIA	MOSCOW – ST. PETERSBURG	271	DIESEL	LOCOMOTIVE TEP 80-002
2002	SPAIN	LERIDA – ZARAGOZA	256.4	DIESEL	TALGO XXI
1901	GERMANY	MARIENFELDE – ZOSSEN TEST TR.	162	ELECTRIC	SIEMENS & HALSKE RAIL CAR
1903	GERMANY	MARIENFELDE – ZOSSEN TEST TR.	210.2	ELECTRIC	AEG RAIL CAR
1955	FRANCE	LAMOTHE –MORCENX	331	ELECTRIC	ALSTHOM ELECTRIC LOCO BB9004
1981	FRANCE	MIOLINS – EN TONNERROIS	380.4	ELECTRIC	TGV –PSE16
1988	FRANCE	PASILLY – TONNERRE	408.4	ELECTRIC	TGV-PSE 88
1990	FRANCE	COURTRALAIN – TOURS	515.3	ELECTRIC	TGV (ATLANTIQUE) 325
2007	FRANCE	PARIS – STRASSBOURG	574.8	ELECTRIC	TGV V150 4402

Source: Research on Optimum Speed for High Speed Lines (Volume I) – International Union of Railways UIC, October 2012

The increase in speed records also resulted in improvement average speeds of trains and the improvements right through the twentieth century were remarkable. The introduction of High Speed Trains with their dedicated infrastructure and rolling stock pioneered by the Japanese 'Bullet Trains' as early as 1964 gave further impetus to rail travel with the massive reduction in journey times. The French TGV trains were able to achieve similar speeds some years later. Table 3.7-2 gives details of the development of commercial / average speeds of trains in various countries.

**Table 3.7-2 Average Rail Speed Established on Selected Routes in Various Countries**

COUNTRY	SECTION	TYPE	TRAIN	DISTANCE (Km.)	YEAR	AVERAGE SPEED (Kmph.)	MAXIMUM SPEED (Kmph.)
UK	Swindon - London	Steam	Cheltenham Spa Express	124	1932	<b>114.8</b>	129
Germany	Berlin – Hamburg	Diesel	Fliegender Hamburger	286	1933	<b>124.3</b>	160
USA	Sparta – Portage	Steam	Morning Hiawatha	126	1939	<b>130.4</b>	161
USA	Chicago-Denver	Diesel	Denver Zephyr	1636	1936	<b>134.0</b>	187
France	Paris – Dijon	Electric	Mistral	315	1964	<b>132.1</b>	160
Japan	Tokyo –Osaka	Electric	Hikari Shinkasen	515	1965	<b>162.8</b>	210
France	Paris – Lyon	Electric	TGV Sud-Est	429	1989	<b>214.0</b>	260
Japan	Hiroshima Kokura	Electric	Nozomi Shinkansen	192	1997	<b>250.4</b>	300
France	Lyon Aix en provence	Electric	TGV Duplex	290	2005	<b>263.3</b>	320
France	Lorraine - Champagne	Electric	TGV POS	168	2007	<b>279.3</b>	320
China	Wuhan -Guangzhou	Electric	CRH2	922	2009	<b>313.0</b>	350

Source: Research on Optimum Speed for High Speed Lines (Volume II) – International Union of Railways UIC, October 2012



It will be observed that with the Introduction of High Speed Train operation average speeds are now in the 200 to 300 Kmph range and maximum permissible speeds have grown to 250 to 350 Kmph. On Indian Railways whereas several advances have been made in Rail Transportation the Maximum and Average Speeds of Passenger Trains are still at the level of what had been achieved in the early years of the 20<sup>th</sup> Century in developed countries.

### 3.7.3 Progress of Speed in Rail Transport – Indian Railway Experience

The first railway in India came in 1853 when the Great Indian Peninsula Railway ran a train from Mumbai (Bori Bunder) to Thana. Thereafter, the growth of the network was rapid. Even then in the early years speed was a consideration. In 1886 the journey from Delhi to Howrah a distance of 1526 Km. took over 43 hours at an average speed of about 35 Kmph, by 1889 the distance was covered in 37 ½ hrs or an average speed of 40 kmph and some years later was further reduced to 31 ½ hrs. By 1906 the journey time was down to 28 ½ hours or an average speed of 50 Kmph. The Steam Locomotives designs used on the IR System were constantly upgraded. Major upgrades took place in 1905 or so with standardised BESA (British Engineering Standards Association) designs being developed, later 1925-28 the Indian Standard Design being coming out for various services and further improvements in 1940's and 1950's the Journey times as a result also improved. A maximum speed of about 100 Kmph was achieved by steam hauled trains. With few stoppages even with Steam Locomotives fairly good average speeds were possible. Although Diesel locomotives provided considerable improvement in terms of acceleration capability and no requirement for watering or coaling better average speeds could be achieved. The Table below shows the change in speeds on two routes over time. The major improvement came with the introduction of the Rajdhani Express in March 1969 between Howrah and Delhi with a maximum permissible speed of 120 Kmph. As will be seen since then though speed has gone up to 140 Kmph the improvement has been marginal.

**Table 3.7-3 Change in speed over time on Delhi – Mumbai and Delhi – Howrah Routes.**

	TRAIN NAME	YEAR	TRACTION	FROM	TO	DISTANCE	JOURNEY TIME	AV. SPEED	MAX. SPEED
1	Frontier Mail*	1928	STEAM	Bombay	Delhi (Delhi Jn)	1392	23.5 hrs	59 KMPH	
2	Golden Temple Mail (* Name Changed)	2014	ELECTRIC	Bombay	Delhi (Nizamuddin)	1377	22.5 hrs	61 KMPH	110 KMPH
3	Rajdhani Express	2014	DIESEL	Bombay	New Delhi	1384	16 hrs	87 KMPH	140/120 KMPH
3	Calcutta Delhi Mail	1906	STEAM	Howrah	Delhi Jn	1444	28 ½ hrs	50 KMPH	
4	Kalka Mail	2014	ELECTRIC	Howrah	Delhi Jn	1444	26 hrs	55 KMPH	110
5	Rajdhani Express	1969	DIESEL	Howrah	New Delhi	1447	17.20 hrs	83 KMPH	120 KMPH
6	Rajdhani Express	2014	ELECTRIC	Howrah	New Delhi	1447	16.55 hrs	86 KMPH	140 KMPH

Source: Study Team Research

There has therefore been only a marginal improvement in speeds both commercial and maximum permissible speed over the last century. The modest achievements in speed of passenger train speeds on Indian Railways has resulted in IR exploring options for introducing faster trains on the system, particularly as with the development of the Dedicated Freight Corridors there will be significant additional capacity on the existing trunk routes.

### 3.7.4 Present Policy Regarding Increasing Speed of Passenger Services on IR

The maximum permissible speed for most Mail/Express train services on Indian Railways is 100 or 110 Kmph. In the case of some Rajdhani & Shatabadi Express Trains it is 140 Kmph on very few routes viz. New Delhi - Howrah and New Delhi to Agra (150 Kmph on part of the route). On some others for Rajdhani Express, Shatabadi and Duronto trains it is 120 Kmph. The maximum permissible

speed is dependent upon track structure, signalling system, coaching stock and locomotive used to haul the trains. As the maximum permissible speed of trains on Indian Railways has remained in the 100 to 120 Km/h range for many decades there is now growing clamour for improving speeds of passenger services. As a result the Indian Railways is adopting a two pronged strategy for increasing speed. It plans to augment speed initially to 160 Km/h and subsequently to 200 Km/h on IR's existing Broad Gauge routes. This increase of speed to 160 – 200 Km/h is known as 'Semi High Speed'. The plan will be implemented in a phased manner and its implementation will depend upon political will, availability of funds and the priority IR assigns to the scheme over several competing requirements like augmenting capacity, gauge conversion, safety works etc. And also Indian Railways proposes to augment speeds to 250 - 350 Km/h on a few new lines dedicated to High Speed Train operations and with new rolling stock. A number of such corridors have been identified and Feasibility Studies have been initiated for these include Delhi – Chandigarh – Amritsar, Hyderabad – Vijayawada – Chennai, Chennai – Bengaluru – Coimbatore – Ernakulam, Ahmedabad – Mumbai, Delhi – Agra – Lucknow – Varanasi – Patna and Howrah to Haldia.

### 3.7.5 Plan for Introducing Semi High Speed Trains with Maximum Speed of 160 Km/h

Indian Railways at present plans to upgrade speeds from a present level of Maximum Permissible Speed of 120-140 Km/h (for some trains only like Rajdhani & Shatabdi Express trains) to 160 Km/h in the first phase and to 200 Km/h in the second phase on selected routes. The routes identified so far for a Maximum Permissible Speed of 160 Km/h are:

- **New Delhi to Agra Cantt.** as this is a very popular route used by International & Domestic tourists who visit the Taj Mahal
- **New Delhi to Chandigarh** which is a very busy and popular route with three pairs of inter-City Shatabdi Expresses and one pair of Janshatabdi Express trains already running every day and
- **New Delhi to Kanpur** which is also a very busy stretch of the Delhi to Howrah Trunk Route and as Kanpur is an important commercial and industrial centre in Uttar Pradesh. Moreover, Kanpur is the junction Station for going to nearby Lucknow, the State Capital.

The New Delhi to Agra Route is proposed to be upgraded to 160 Km/h by the end of 2014 and the other two routes shall be taken up in 2015. Work to be done on this section has already been identified. The newly formed High Speed Railway Corporation (HSRC) is expected to engage consultants for the Delhi - Chandigarh and New Delhi – Kanpur routes. HSRC has also received a separate and independent proposal from the Government of Karnataka. This is for a Semi High Speed link between the State Capital of Bangalore and the city of Mysore which is an important administrative, business and educational centre apart from being a Tourist Centre and the Capital of the Princely State of Mysore. The proposal is for an independent new line on Broad Gauge with a maximum speed of 200 Km/h. The HSRC is presently initiating Feasibility Study for the Project which will also examine options for funding the project line. The proposal will help HSRC crystallize infrastructure requirements for Broad Gauge including track, signalling & Telecom and Electric traction for 200 Km/h will help in augmenting speeds on existing BG routes.



Figure 3.7-1 Semi High Speed Railway Route

### 3.7.6 Augmenting Infrastructure for Up-gradation to 160 Km/h

The key items in case Delhi to Agra increase of Speed to 160 Km/h that need to be implemented are provision of thick web switches at certain remaining locations, installation of a Route Relay Interlocking facility at Agra Cantt., provision of fencing on the line at vulnerable locations to prevent animals from crossing, attention to certain curves, through packing, completion of TPWS (Train Protection and Warning system) works, commissioning of an additional Traction Sub Station on the route. As the Maximum permissible Speed is already 150 Km/h on a portion of the route the increase in speed is expected to give a marginal benefit only. However, it is proposed to reduce journey time by almost half an hour from an overall journey time of 130 minutes by trimming the Engineering Allowance and Traffic recovery time provided, transferring some passenger movement to a third line which is open but only used for freight and through benefits that will accrue from the installation of a Traction Sub Station and route Relay interlocking. The key elements for augmenting speeds to 160 Km/h on any section shall be the (i) Fencing at vulnerable locations, (ii) provision of thick web switches, (iii) installing an appropriate train protection system like TPWS to prevent risk of collisions (iv) maintenance of track geometry to a very high standard and (v) IR Standard IV interlocking. The final clearance for increasing speed for passenger services is given by the Commissioner of Railway Safety and he shall do so if he is fully satisfied with the results of the Oscillation Speed trial results that are conducted. It needs to be noted that the basic track structure, latest Rolling stock available such as the LHB Coaches and WAP 5 Electric Locos are already designed and fit for 160 Km/h operation on trunk routes.

## Chapter 4 Formulation of HSR Basic Plan in India

### 4.1. Definition of High Speed

#### (1) Definition of HSR in this project

For the purpose of analysis about world high speed rail technology and thereafter exploring formulation of high-speed rail plan, first of all definition of high speed rail should be given. However International Union of railways (UIC) even has stated about ‘definitions of high speed’ as bellow.

‘We have deliberately used the word “definitions” in the plural because there is no single standard definition of high speed rail (nor even a standard usage of the term: sometimes it is called “high speed” and sometimes “very high speed”). The definitions vary according to the criteria used since high speed rail corresponds to a complex reality’

However UIC often refer to Europe Union (EU) definition, given in Directive 96/48. High speed rail is a combination of all the elements which constitute the system, therefore the Directive describes high speed infrastructure and rolling stock respectively and the definition is divided into two cases, new constructed lines and upgraded lines like bellow.

- Infrastructure
  - Specially built High Speed lines equipped for speed generally equal to or greater than 250km/h
  - Specially upgraded High Speed lines equipped for speeds of the order 200 km/h
- Rolling stock, The High Speed advanced-technology trains
  - at a speed of at least 250 km/h on lines specially built for High Speed, while enabling speeds of over 300 km/h to be reached in appropriate circumstances
  - at a speed of order 200 km/h on existing lines which have been or are specially upgraded

‘High speed rail travel’ is mentioned in ‘Indian Railways Vision 2020’ and it is also described in 2 levels divided.

- High-Speed Trains, To provide bullet train service at 250 - 350 km/h
- Raising of speed, regular passenger trains to 160-200 km/h on segregated routes

In this study, a new HSR line will be constructed whichever it is partially or completely. All these things considered, definition of high speed is due to be a speed equal or greater than 250 km/h on lines specially built for high speed.

#### (2) Increasing Operation Speed

The full-fledged era of HSR opened in 1964 on a new high speed line. When the first high-speed train operated, the maximum operation speed was 210 km/h. That has been increasing since then due to development of various technical aspects, such as infrastructure, rolling stock and operations. Figure 4.1-1 shows evolution of maximum speed on rail.

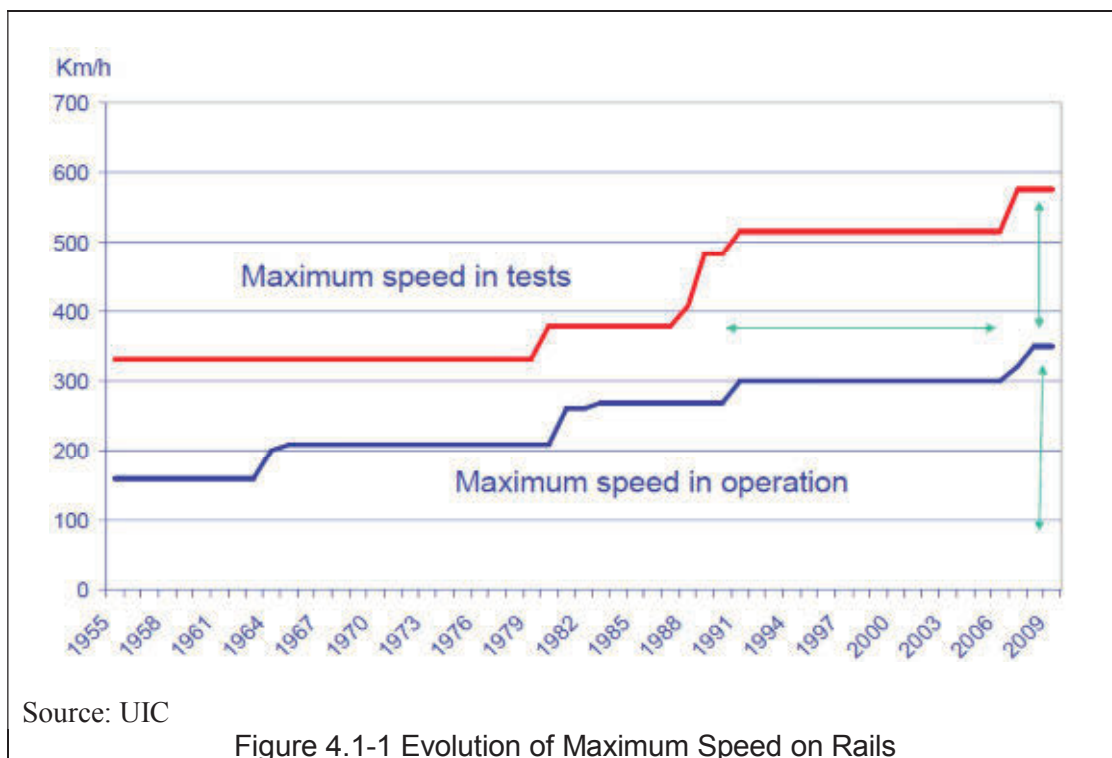

After the year 1980, maximum operation speed steady increased along with maximum speed in tests. Currently 300 km/h or more is the mainstream of maximum operation speed of HSR.

### (3) Expanding HSR network

The world's earliest HSR started its operation in Japan in 1964. It is only 515 km in length. France's TGV began in 1981 and other European countries have followed. During the 21<sup>st</sup> century, high speed lines have been constructed in Asia countries, South Korea, Taiwan and China.

According to UIC, there are 14 countries where commercial high speed operation over 250 km/h is realized at the instant of 1<sup>st</sup> Nov. 2013. (Table 4.1-1 )



Table 4.1-1 High Speed Lines in the World

Country	Number of lines	Year, the first operation	Maximum speed (km/h)	Distance (km)	Track gauge (mm)
Japan	6	1964	320	2388	1435
France	9	1981	320	2036	1435
Italy	7	1988	300	923	1435
Germany*1	11	1991	300	1334	1435
Spain	15	1992	300	2515	1435
Belgium	4	1997	300	209	1435
United Kingdom	2	2003	300	113	1435
South Korea	2	2004	300	412	1435
Taiwan	1	2007	300	345	1435
Switzerland	1	2007	250	35	1435
China	26	2008	*2. 300 (350)	9867	1435
Turkey	2	2009	250	444	1435
The Netherlands	1	2009	300	120	1435
Austria	1	2012	250	93	1435

(Note)

\*1: include ABS partially ; up-graded line, of which maximum operation speed 230 km/h

\*2: Maximum operation speed was reduced from 350 km/h down to 300 km/h in July 2011

Source : UIC data (updated 1<sup>st</sup> November 2013) compiled by Study team

In these countries stated in table 4.1-1, all of track gauges are standard gauge and most of the maximum speed is over 300 km/h.

Hereafter the principal eight countries such as Japan, France, Italy, Germany, Spain, South Korea, Taiwan, and China, which operates at speed equal to over 300 km/h and over 300 km length of high speed lines, are mainly being analyzed in high speed rail technology.

## 4.2 Necessity of HSR System in India

### 4.2.1 Role of High Speed Rail

Railway can be classified into 3 types such as Urban or Suburban Rail, Conventional Intercity Rail and High Speed Rail. Urban or Suburban Rail is a mode to carry passengers in urban area or between the city and its suburban by high frequent service and its distance between the stations is short (from a few km to few dozen km). Typical example of Urban Rail in India is Delhi Metro in Delhi. It operates by maximum speed of 80km/h and runs up to every 3 to 6 minutes. And Conventional Intercity Rail is a mode to transfer passenger between the cities and its distance between the stations is about several tens of km. It runs by the speed of a hundred and several tens of km/h and its typical examples are Shatabdhi Express or Rajidhani Express operated by IR and the important cities are connected by these trains.

On the other hand, High Speed Rail is a mode to connect large cities in a short time by maximum speed of over 300km/h. the competing mode of HSR is mostly airplane and HSR is competitive in the range of between 300km and 800km in distance and around 4 hours in traveling time due to the improvement of train speed and long ours security check at the airport.

### 4.2.2 High Speed Rail System is Quite Different System from Conventional Line System

High Speed Rail which is operated with the maximum commercial speed of 320km/h in the world has been established by assembling the technologies which are different from the ones used in conventional line. To achieve safe high speed operation, more precise technologies should be introduced since vibration of rolling stock is greater and in case of accident the damage will be huge because of its high speed. It is written that high speed rail system is composed by the subsystems which are quite different from conventional line.

The technology development of High Speed Rail has been done to achieve much faster speed operation than the speed of conventional line from the beginning of its development. A lot of different and modern technologies such as the structure and maintenance methodology of track, rolling stock, electrification system and Automatic Train Control (ATC), etc. have been adopted to HSR.

With regard to track, there were occurrences of track irregularity caused by high lateral force generated from high speed operation and the technical development regarding track maintenance to deal with such problem of high lateral force has been created. As of now, ballast-less track and very strict maintenance standard compared to the one of conventional line have been introduced to achieve safe high speed operation.

As to rolling stock, the technology development regarding running resistance in high speed are, adhesion coefficient, running stability, power collection of pantograph, bearing metal, wind pressure occurred when the train runs into the tunnel, passing of trains in opposite direction, and braking distance, etc. have been created. Rolling stock which has aerodynamic shape and sophisticated body structure has been created.

As to electricity, there was development of technologies such as catenary structure endurable for high speed and high frequent operation and enforcement of its material, compounding of catenary and installation of vibration reduction equipment to reduce the vibration caused by high speed operation. Reliability of HSR has been improved.

As to signaling system, to achieve safe high speed operation, as an example, Automatic Train Control (ATC) which displays signal on the indicator in the rail car (cab signal) and interlocks brake with cab signal has been created and installed since there is no margin for human error.

As mentioned above, technologies to achieve safe high speed operation has been introduced in various elements which compose high speed rail system such as track, electric, signal and rolling stock, etc. thus high speed rail is peculiar system which needs fast technological upgrade.

#### 4.2.3 Necessity of HSR in India

HSR is needed as a measure to archive several goals and demands indicated in Railway Vision 2020 with its various features. 6 main items which HSR will satisfy are written blow:

1. Safety is the top priority of HSR
2. High Capacity
3. High Frequency
4. Network Expansion
5. High Energy Efficiency
6. Strong Infrastructure and HSR System for Natural Disaster

##### (1) Safety

As indicated in Railway Vision 2020, HSR System needs to aim at making railway operations free of accidents, derailment, collision or fire on trains. Safety is highly required for HSR.

HSR has been established as very safe transport system mainly in East Asia and Europe since Shinkansen was opened in 1964 in Japan.

HSR is required for safety transport network in India.

##### (2) High Capacity/Frequency

As indicated in Figure 4.2-1, passenger transport activity is growing rapidly in India and its growth is driven by rapid population growth, economic growth, urbanization and motorization.

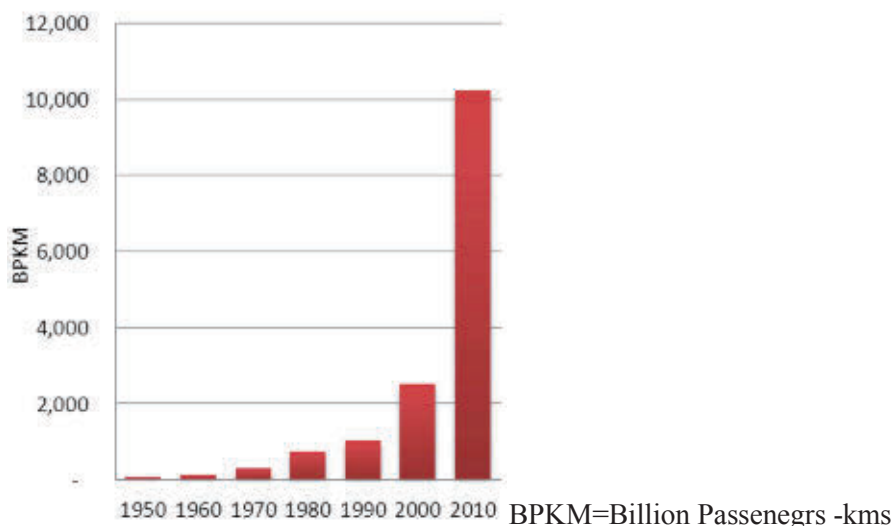

\*Estimation by different Ministries and Planning Commission. Estimations are on higher side as compared to much other estimation.

Source: TERI

Figure 4.2-1 Trends in Passenger Mobility in India 1950 - 2010

HSR should be one of the solutions to transport the high passenger demand by high capacity and frequency transport service.

### (3) Network Expansion

As per the Railway Vision 2020, new 25,000km railway line will be constructed by 2020 to expand and strengthen the railway network in India. HSR will also be a part of this expansion and 4 HSR Corridors out of 7 corridors planned in India are to be constructed by 2020.

HSR strengthen transport network between major cities in the world with its high-speed performance and mass transport performance and it is expected that HSR will strengthen transport network of major cities in India.

### (4) High Energy Efficiency

As indicated in Railway Vision 2020, Indian Railways has made efforts to reduce carbon footprint for climate protection by some measures.

HSR is a mode with high energy efficiency compared with other modes (Figure 4.2-2). HSR as an environment-friendly measure matches the way which Indian Railways goes to protect environment including energy serving and reduction in carbon emission.

PKM/Unit of Energy (kWh)

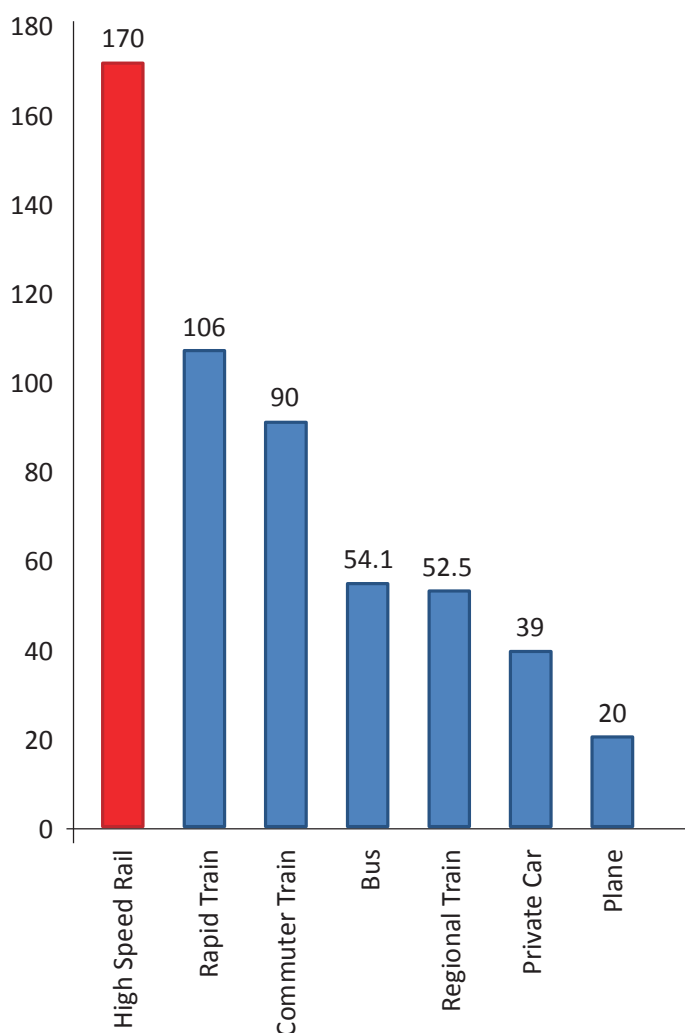

Source: TERI

Figure 4.2-2 Energy Efficiency – Passenger Transit

#### (5) Strong Infrastructure and HSR System for Natural Disaster

It is very important to be strong against natural disasters. Maharashtra and Gujarat state are the place to be anticipated the occurrence of several natural disasters such as rain, storm and especially earthquake. The earthquake happened in Gujarat state in January, 2001 and it wreaked enormous damage.

The strong infrastructure is required to secure stable transport network in case of natural disaster. HSR is established as strong transport system to limit damage from such natural disasters by accumulation of technology development in the world.



## 4.3 Basic Characteristics of HSR System in the World

### 4.3.1 Overview of Main Characteristics

This section describes main characteristics of world principle HSR network.

HSRs in the world are described in the country-wise chronological order of inauguration

#### 1) Japan (1964)

- Japan started revenue service operation of the Tokaido Shinkansen railway (route length approximately 515 km) at a maximum speed of 210 km/h in 1964 to become the first HSR operating country in the world.
- Japan has established a HSR system to run high-speed trains which adopt Electric Multiple Units,(EMUs) on the tracks constructed to high-level specification by adopting the standard gauge (different from that of conventional railways), that have thoroughly eradicated accidents by eliminating level crossings and applying a high-reliability train protection system with a cab-signal system.
- The Tokaido Shinkansen railway, which is completely independent of conventional (narrow-gauge) railways, is dedicated to high-speed passenger train, realizing high-frequency operation at headways of four minutes during the time zone of most frequent train operation.
- The HSR network has steadily been extended thereafter to constitute a scale over 2,000 km in length, with the maximum train speed increased meanwhile to 320 km/h.
- Although high speed trains run in HSR sections in principle, due to the difference in the track gauge existing between HSRs and conventional ones, high speed trains implement through-operation to/from some conventional lines of which track gauge has been converted into standard gauge.
  - Construction of HSR to high-level standards independent of conventional railways
  - HSR independent of conventional railways is dedicated to high speed passenger trains
  - Partly through-operation to/from conventional lines via terminals

#### 2) France (1981)

- France started operation of TGV trains on a 273 km-long section, part of the LGV (HSR) South-East line, at 260 km/h in 1981, as the first high-speed railway operator in Europe or the second HSR operator in the world.
- To run high speed trains under the LGV system, France adopted “an utilizing conventional lines approach” to use (1) a new HSR constructed to high-level standards and (2) part of conventional standard-gauge railways in urban areas, thereby establishing another HSR model, which has been adopted thereafter into railways in different European countries of which conventional lines are of the standard-gauge type.
- As a result of speedup and increases in the demand for high-speed trains, newly built high speed railway sections have become increasingly longer to exceed 2,000 km, thereby constituting a main part of most of the current HSR networks.
- Whereas LGV high speed railways are dedicated to TGV trains, they are operating on conventional lines in the vicinity of stations and terminals.
- TGV high-speed trains are operated to/from remote destinations via terminals or to/from neighboring countries through conventional railways as international trains.
- The maximum design speed is 300 km/h for the South-East and Pacific lines and 350 km/h for the North European line and those constructed thereafter, with the construction standards simultaneously revised. The current maximum speed for revenue service is 320 km/h set for the LGV Mediterranean line.
  - Construction of new railways to high-level standards while partially utilizing

conventional railways

- New-constructed sections of HSR are dedicated to high-speed passenger trains in principle
- Through-operation to/from conventional lines both in the vicinity of stations and via terminals

### 3) Italy (1988)

- The Italian HSR era began in 1988 with the revenue service operation of ETR 450 on 252 km Rome-Florence ‘Diretissima’ the first high speed line in Europe, which is opened partially in 1977.
- Italy electrified its HSR originally under the DC 3 kV system while assuming through-operation to/from conventional railways, which was later converted into the AC 25 kV system that is advantageous for high-speed train operation, however.
- Italy has gradually expanded its HSR network up to a length over 900 km, with maximum train speed raised to 300 km/h, while partly utilizing conventional railways for high-speed train operation.
- Despite that the new HSR in Italy is designed to operate not only passenger trains but also freight trains, freight trains are not operated at the moment.

- Construction of new railways to high-level standards while partially utilizing conventional railways
- New-constructed sections of HSR are dedicated to high-speed passenger trains in principle
- Through-operation to/from conventional lines both in the vicinity of stations and via terminals

### 4) Germany (1991)

- The HSR system started in Germany in 1991 when ICE1 trains ran at 250 km/h in the Hannover-Wurzburg, which is opened partially in 1988 and Mannheim-Stuttgart sections including new-constructed sections of HSR.
- A feature of the high-speed railway network in Germany is that construction of HSR (NBS 250 to 300 km/h) is underway in combination with the improvement of conventional railways (ABS 230 km/h or less).
- While assuming common use with freight trains, the first-generation HSRs were constructed to such specifications as axle load (19.5 t) and maximum gradient (12.5‰). In consideration of the burdens on maintenance, however, the second-generation HSR (Köln-Frankfurt section (NBS)) and those constructed thereafter were designed to different specifications as railways dedicated to passenger train operation.
- In the Hannover-Wurzburg section, freight trains are running at night with the operation time zone separated from that of HS passenger trains.
- Transport of passenger-freight mixed traffic is undertaken on the sections upgraded conventional railways.
- Similarly to TVG, ICE trains are implementing through-operation to/from conventional lines to constitute a high-speed train network including international train operation.
- The HSR network including ABS extends to over 1,300 km to run trains at a maximum speed of 300 km/h.

- Combination of the construction of HSR and improvement of conventional railways
- Freight trains and conventional passenger trains are operating on new-constructed sections of HSR
- Through-operation to/from conventional lines both in the vicinity of stations and via terminals

5) Spain (1992)

- Spain opened the Seville line (length 472 km) in 1992 to start revenue service operation of AVE high-speed trains at a maximum speed of 250 km/h.
  - Despite that the track gauge of conventional railways is broad-gauge (1,668 mm), Spain constructed standard-gauge lines dedicated to high-speed train operation as the HSR network. Because of the difference in track gauge, HSR are completely independent of conventional railways including in station-surrounding areas not like other countries in Europe.
  - Conventional broad-gauge railways were improved in parallel to run trains at a speed higher than 200 km.
  - A HSR network has been constructed into radial directions with Madrid as a center to a total length of approximately 2,500 km, as a second largest scale next to that of China in the world.
  - Through-operation to/from conventional lines is implemented using gauge changeable train sets. Furthermore, broad-gauge high speed trains are also running at a maximum speed of 220 km/h within the network of conventional railways.
  - The maximum speed is currently 300 km/h in HSR sections and 220 km/h on conventional railways. However, the maximum speed is limited to 250 km/h in HSR sections for gauge changeable train sets performing through-operation to/from conventional lines.
- Combination of construction of HSR and improvement of conventional railways
  - HSR independent of conventional railways is dedicated to high speed passenger trains
  - Through-operation to/from conventional lines via terminals deploying gauge changeable high-speed train sets

6) Korea (2004)

- In April 2004, Korea inaugurated the HSR section between Seoul and Daegu (330 km), part of the high speed railway to connect Seoul and Pusan (412 km), and started revenue service operation of KTX trains at a maximum speed of 300 km/h.
  - KTX trains incorporate French TGV technologies and utilize in part conventional railways in the vicinity of stations in urban areas. HSR sections and conventional railways are combined to run KTX trains, in that through-operation is implemented at a midway station of Osong to/from Mokpo on a conventional line.
- Construction of new railways to high-level standards while partially utilizing conventional railways
  - New-constructed sections of HSR are dedicated to high-speed passenger trains in principle
  - Through-operation to/from conventional lines both in the vicinity of stations and via terminals

7) Taiwan(2007)

- Taiwan started revenue service operation temporarily between Banciao and Zuoying in January 2007 and formally in the 345 km section beyond Taipei in March 2007 at a maximum speed of 300 km/h.
- As the track gauge of conventional railways is narrow-gauge (1,067 mm), the standard-gauge HSR, which has been constructed to high-level specifications, is completely independent of conventional railways and used as a railway dedicated to

high speed passenger trains.

- Train sets were originally designed assuming push-pull operation based on a proposal of European suppliers. In the wake of the Great Taiwan Earthquake in 1999, however, Taiwan reviewed the advantage of Japanese system to incorporate the urgent earthquake detection and alarm system and changed its policy thereafter to adopt Japan's rolling stock and signal systems.

- Construction of HSR to high-level standards independent of conventional railways
- HSR independent of conventional railways is dedicated to high speed passenger trains

#### 8) China (2008)

- China adopted "a medium- and long-term railway network plan" in January 2004 to change its policy on the speedup of trains from the conventional railway improvement and domestic technology development schemes to construction of HSR dedicated to passenger transport and introduction of foreign technologies.
- China (1) opened a high-speed passenger transport railway between Shenyang and Quihuangdao (405 km) in October 2003 to run trains at a maximum speed of 250 km/h, (2) started revenue service operation of series of high-speed trains that incorporate foreign technologies at a maximum speed of 200 km/h in April 2007 and (3) inaugurated a HSR featuring a design maximum speed of 350 km/h between Beijing and Teijin (118 km) in August 2008 to start revenue service operation at a maximum speed of 350 km/h.
- The HSR network has expanded at a skyrocketing speed thereafter up to a length of 9,867 km (as of November 2013) to claim the largest scale in the world.
- The HSR network in China is being constructed to combine (1) HSR for operation at 250 km/h or over and (2) HSR for operation at less than 250 km/h and (3) improvement of conventional railways for operation at approximately 200 km/h.
- There are various types of high speed trains, including those running only within the HSR network and those performing through-operation to/from conventional lines.
- There are different methods to use HSR, in that some are dedicated to passenger transport while others for mixed transport of passengers and freights.
- After the revision of train operation diagrams in July 2011, the maximum operation speed of high-speed trains has been reduced from 350 km/h down to the present 300 km/h for revenue service.

- Construction of HSR with and without using in part conventional railways, combination with improvement of conventional railways
- Widely-ranged operation modes in different sections, from exclusive use by passenger trains to common use with freight transport

#### 9) Summary

Table 4.3-1 summarizes main characteristics of world principle HSR networks from the viewpoints of construction methods, operation methods.

Table 4.3-1 Summary of World Principle High Speed Networks

	Japan	France	Italy	Germany	Spain	China	Taiwan	South Korea
Maximum operation speed (km/h)	320	320	300	300	300	300 (350)*1	300	300
<b>Construction Method</b>								
• Full construction of new high speed line independent of conventional line	✓				✓	✓	✓	
• Utilizing conventional line partially		✓	✓	✓		✓		✓
• Upgrading conventional line				✓	✓	✓		
<b>Operation Method</b>								
• Independent	✓				✓	✓	✓	
• Interoperability 1		✓	✓	✓		✓		✓
• Interoperability 2	✓ *2	✓	✓	✓	✓ *3	✓		✓
<b>Operation on high speed line</b>								
• High speed passenger trains	✓	✓	✓	✓	✓	✓	✓	✓
• Conventional passenger trains				✓		✓		
• Freight trains		✓ *4		✓ *5		✓		

Interoperability 1: High speed trains are operating on conventional lines between terminals, in the vicinity of stations and terminals.

Interoperability 2: High speed trains are operating into conventional lines via terminals.

\*1. After the revision of train operation diagrams in July 2011, the maximum operation speed has been reduced from 350 km/h down to the present 300 km/h.

\*2. For this purpose, conventional lines' gauges are widened to standard gauge.

\*3. Interoperability in Spain uses gauge-changeable Rolling-stock

\*4. Freight trains have been suspended since 2012 except Postal

\*5. Freight trains are operating only at night separated from high speed passenger and not operating on recently constructed high speed line.

Source: Compiled by Study Team



### 4.3.2 Construction Method

#### (1) Station Location and Interoperability

##### 1) Two Kinds of the Impact of High Speed Railway

To discuss the station location of HSR and interoperability, these 2 impacts generated from HSR should be considered.

1. Improvement of Transport Service
2. Opportunity for Regional & Urban Development

As mentioned above, for railway users and regional & urban development, the location of HSR in a city is very important issue. The location of HSR station can be classified into following types.

#### 2) Type of Station Location

The types of station location and the features of each station location are mentioned below and show in Figure 4.3-1

<p>1. HSR enters into the Existing Station of Conventional Railway by Dedicated HSR Line</p> <p><b>Features and points to be considered</b></p> <ul style="list-style-type: none"> <li>Juxtaposed New HSR Station to Existing Station</li> <li>Good Connectivity of HSR with Conventional Railway</li> <li>Space for HSR is needed</li> </ul>
<p>2. HSR enters into the Existing Station of Conventional Railway by Interoperability</p> <p><b>Features and points to be considered</b></p> <ul style="list-style-type: none"> <li>Using Conventional Railway and Existing Station</li> <li>Enough track capacity for HSR is needed</li> </ul>
<p>3. New HSR Station at the New Location</p> <p><b>Features and points to be considered</b></p> <ul style="list-style-type: none"> <li>Consideration of Accessibility with Existing Railway, Mass Transport System and Road is important</li> <li>New Urban Development will be expected</li> </ul>

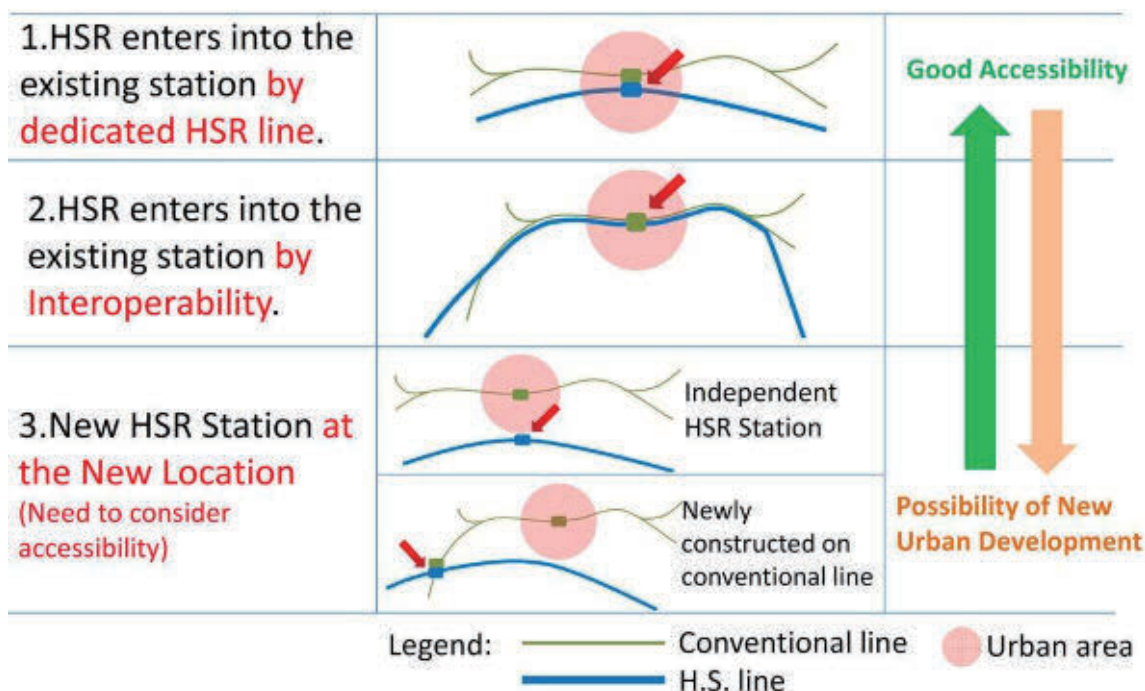

Figure 4.3-1 Types of Station Location

## (2) Construction Methods

As mentioned above, for railway users and regional & urban development, the location of HSR station in a city is very important issue. The location of HSR station can be classified into following 2 types

- HSR to high-level standards independent of conventional railways
- HSR utilizing existing conventional railways

To utilize existing conventional railway, the following prerequisite will be needed.

- Needs of enough spare track capacity for HSR in conventional line
- Technical compatibility of both H.S. line and conventional line needs to be same.

### 4.3.3 Operation Method

Operation method, which is one of basic characteristics, is closely related to construction method and the role of high speed rail.

When a track capacity of a conventional line is approaching its limit, usually the method of full construction of a new high speed line is adopted in order that track capacity and operation speed will be dramatically improved. Some convenience can be achievable by measures to improve accessibility.

On the other hand, when a conventional line has a spare capacity and high operation speed is required, the method of utilizing conventional lines partially or upgrading conventional lines is often adopted. In the latter case, Interoperability is of necessity, while in the former case a high speed service which is independent of conventional trains' operation could be realized.

When the method of utilizing conventional lines partially or upgrading conventional lines is used, these lines continue the functions of the conventional lines, taking the form of mixed transport by operating freight trains, low-speed passenger trains and high speed trains on these lines.

Meanwhile when the method of full construction of a new high speed line is adopted, a dedicated high-speed passenger train line is designed in many cases from the viewpoint of safety and efficiency. In Europe, there are some examples of high-speed lines designed for mixed track purpose. However, since frequency of high-speed railway operation is constrained under mixed traffic, many new high-speed lines have been constructed as a dedicated high-speed passenger line.

Three types of operation methods between a High-speed line and a conventional line is shown in Figure 4.3-2.

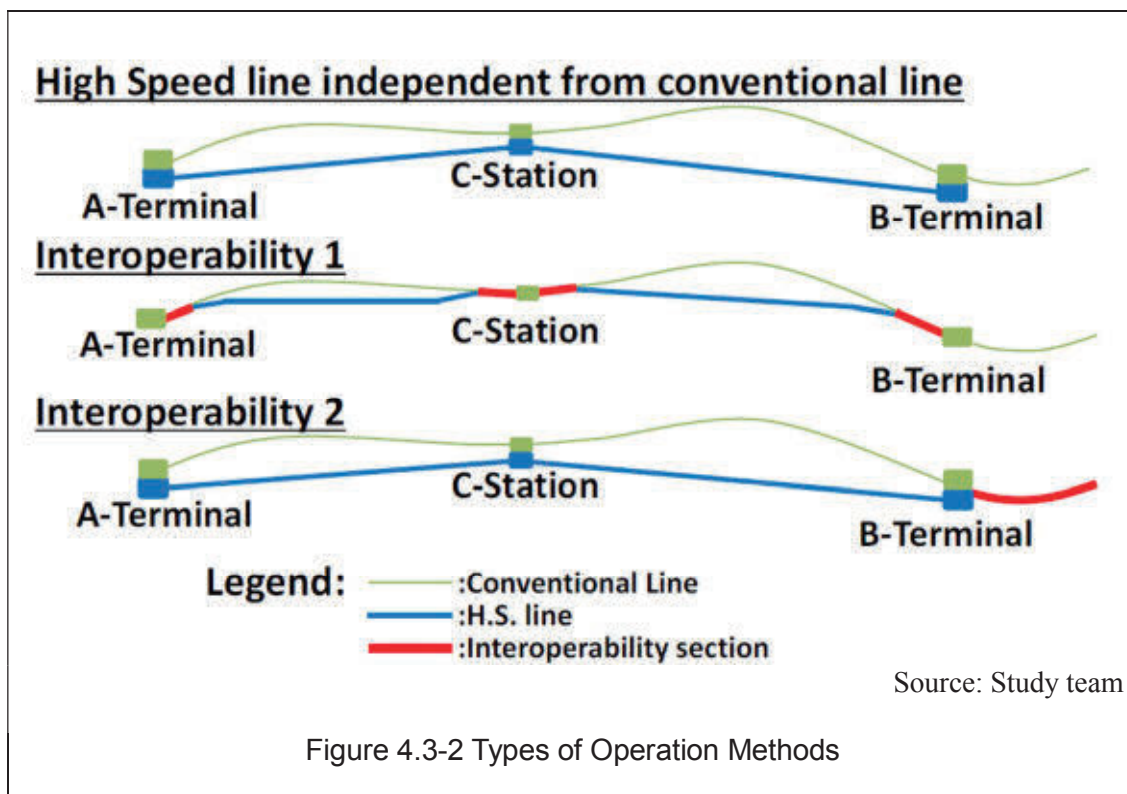

Figure 4.3-2 Types of Operation Methods

The method that high speed trains operate independently from conventional line, which is sometimes called dedicated line, is adopted in Japan, Taiwan-China and Spain. “Interoperability 1” is a method that high speed trains operate to/from conventional lines both in the vicinity of stations and terminals. This method is often used for high-speed lines in Europe. “Interoperability 2” is a method that high speed trains operate to/from conventional lines via terminals.

Table4.3-2 The Operation Method of High-speed Train in Major Countries

Country	Japan	France	Italy	German	Spain	South Korea	Taiwan	China
Independent	✓				✓		✓	✓
Interoperability 1		✓	✓	✓		✓		✓
Interoperability 2	✓ *1	✓	✓	✓	✓ *2	✓		✓

\*1 For this purpose, conventional lines’ gauge are widened to standard gauge.

\*2 Interoperability in Spain uses gauge-changeable Rolling-stock.

Source: Study team

As shown in Table4.3-2, Interoperability 1 is a main method in Europe. These reasons are as follows.

- Gauge of the HSR lines and conventional lines are same.
- Relatively, there is enough spare track capacity of conventional lines.

On the other hand, HSR lines in Japan, Spain and Taiwan adopt full construction of new HSR line (standard gauge; 1,435 mm) independently from conventional line. The reasons are as follows.

- Gauge of conventional line is narrow-gauge (1,067 mm) in Japan and Taiwan-China.
- Gauge of conventional line is broad-gauge (1,668 mm) in Spain.
- Regarding Tokaido-Shinkansen in Japan, new HSR line (standard gauge; 1,435 mm) was constructed because the track capacity of conventional lines was insufficient by increasing number of passengers.

Table4.3-3 shows types of trains which are operated on HSR.

Table4.3-3 Operation on HSR

	Operation on HSR			Remarks
	Passenger (High-Speed)	Passenger (Conventional line)	Freight	
Japan	✓			
France	✓		✓*	-Maximum operation speed TGV Postal 270 km/h Freight train 200 km/h *Freight trains have been suspended since 2012 except TGV Postal
Italy	✓			
Germany	✓	✓	✓	-Maximum operation speed Conventional train Passenger IC (InterCity train) 200 km/h EC (EuroCity train) 200 km/h Freight train 160 km/h -Freight trains are operated only at night separated from HSR
Spain	✓		✓*	-Maximum operation speed Freight train 150 km/h *Only between Barcelona and Figueres; distance 129km -Freight trains are operated only at night separated from H.S.P
South Korea	✓	✓*		*Convention passenger train had been operated into High-Speed line partially (2006-2008) GwangMyeong Shuttle; Gwangmyeong-Siheung 4.3km
Taiwan	✓			
China	✓	✓	✓	-Freight train is used High-speed line partially

Source: Study team

As shown in Table 4.3-3, Conventional passenger trains have been operated on High-speed line in Germany and China. Although Freight trains have been operated on High-speed line in France, Germany, Spain and China, they are mere some exceptions.

It is because adopting mixed traffic on high-speed line, there are certain problems to be considered as follows.

- It is difficult to operate various types of trains on the same line at high-frequency due to

significant difference of speed.

- Freight train operation should be separated from high speed trains, for example only during night time, so that safety-problems caused by the cross passing of a freight train and a high speed train would not occur.

Regarding this MAHSR corridor, it is described in the Draft terms of Reference (TOR) that MAHSR would be exclusive for passenger service. Therefore this feasibility study is proceeding as a line dedicated for high-speed passenger service.



#### 4.4 Interoperability and Gauge Selection

##### 4.4.1 Interoperability

###### (1) Prerequisite for Interoperability

As mentioned before, there are two types of interoperability shown in Figure 4.4-1. One is that high speed trains are using conventional lines ‘between terminals’ in the urban area of major cities; Interoperability 1. The other is that high speed trains operate directly through into conventional lines via terminals; Interoperability 2. Of course, there are a combination case of Interoperability 1 and 2.

In both cases; Interoperability 1 and 2, realizing interoperability, if not more 2 prerequisites are necessary. Conventional lines must have spare track capacity, and high speed rolling stock requires compatibility. Of the two, track capacity is an absolutely important criterion.

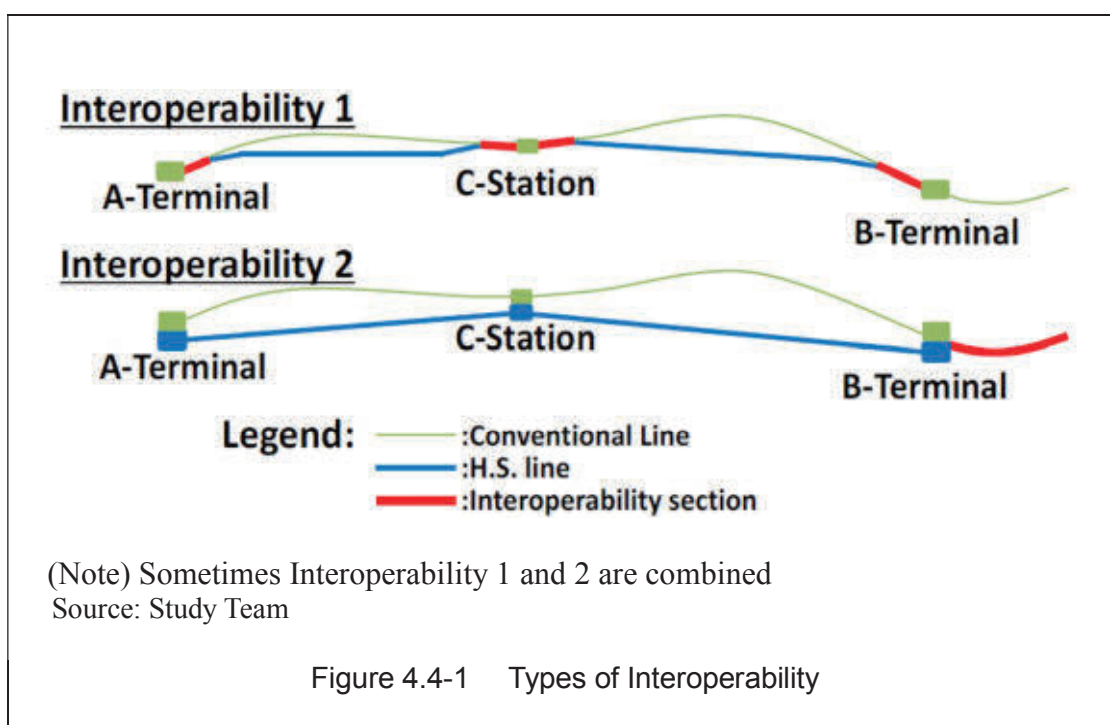

###### (2) General advantages and disadvantages of adopting Interoperability

There are some advantages and disadvantages of adopting interoperability in comparison with HSR independent from conventional lines. General advantages and disadvantages of adopting interoperability are shown in Table 4.4-1.

Table 4. 4-1 Advantages and Disadvantages of Adopting Interoperability

	Interoperability between H/S lines and conventional lines		H/S line independent from conventional lines
	Interoperability 1	Interoperability 2	
<b>Prerequisite</b>	<ul style="list-style-type: none"> <li>Conventional lines require enough spare track capacity.</li> <li>HS rolling stock require technical compatibility between HSR line and a conventional line.</li> </ul>		
<b>Advantage</b>	<ul style="list-style-type: none"> <li>Probability in reduction of infrastructure construction cost</li> </ul>	<ul style="list-style-type: none"> <li>Passenger need not to transfer between H/S and conventional trains</li> </ul>	Realizing <ul style="list-style-type: none"> <li>High safety</li> <li>High track capacity</li> <li>High frequency operation</li> <li>High energy efficiency due to lighter weight of rolling stock</li> </ul>
<b>Disadvantage</b>	<ul style="list-style-type: none"> <li>Safety Issue</li> <li>Less stability and longer journey time</li> <li>Restriction of train frequency</li> <li>Need compatibility of technical standard, track gauge &amp; loading gauge</li> <li>Increase of rolling stock cost due to compatibility of signaling, power supply and necessity of high-level crush-worthiness.</li> </ul>	Besides left <ul style="list-style-type: none"> <li>Increase of Rolling stock cost, because additional train-sets are required for operation on conventional line.</li> </ul>	<ul style="list-style-type: none"> <li>Need cost for construction of full line.</li> <li>Need considering accessibility with conventional lines. (Some convenience is achieved by measures to improve accessibility )</li> </ul>

Source: Compiled by Study Team

1) Advantages of Interoperability

Interoperability has advantages on certain prerequisite. The first advantage is that passengers need not to transfer between a high speed train and a conventional train. It can prevent passengers from their physical annoyance and a waste of time for connection and transfer. The second is that utilizing conventional lines' infrastructure, contributes to saving construction of new lines' infrastructure and it would have possibilities of reduction of construction cost.

Besides, rail network whose gauge is unified would be realized, so materials for railways could be commoditized and it might contribute to cost reduction in the future.

Meanwhile HSR line independent from conventional lines are constructed, passenger inconvenience of transfer between a HSR and a conventional line is softened by measures to improve accessibility, (1) good connection between HSR and conventional lines such as transfer on the same platform, (2) good accessibility by elevators, escalators and moving pavements.

2) Disadvantages of interoperability

Admitting these advantages though, there are some important disadvantages of interoperability explained below.

Key Issue: Safety

➤ Safety issue

Safety is the top priority of railways, especially of HSR. Generally speaking, a conventional line is lower safety-condition due to outdated signaling system without back-up system and existence of level crossings. Most of serious accidents of high speed train have occurred on conventional lines.

For example, in 2013, the Antiago de Compostela derailment occurred, when an Alvia; high-speed train in Spain travelling from Madrid to Ferrol, was operating at high speed on a curve about 4 km outside of the railway station. Of the 222 people (218 passengers and 4 crews) aboard, around 140 were injured and 79 died. The curve is on a conventional line after the HSR line. The train was travelling at about twice the posted speed limit of 80 km/h because there is no back-up system for over-speed. (Figure 4.4-2)



Source: elpais.com

Figure 4.4-2 Overturn Caused by Over Speed on a Conventional Line

TGV also have serious accidents on conventional lines. In 1988, TGV from Grenoble to Paris collided with a lorry carrying an electric transformer weighing 100 tonnes at a level crossing and the train driver and a passenger died, and 25 passengers injured. In 2007, TGV from Paris to Geneva collided with a truck at a level crossing. The driver of the truck died and on the train, one person was seriously injured and 24 were slightly injured. (Figure 4.4-3)



Source: [bbc.co.uk](http://bbc.co.uk)

Figure 4.4-3 Collision with a Lorry at a Level Crossing

In 2013, a KTX bullet train and a Mugunghwa passenger train, a conventional train, heading from Daegu Station on the Gyeongbu line towards Seoul collided. Shortly after another KTX train heading towards Busan collided into the stopped train, causing a second accident. There are no injuries among the passengers because trains were on very low speed. (Figure 4.4-4)



Source: [koreaherald.com](http://koreaherald.com)

Figure 4.4-4 Collision between Trains in a Conventional Station



Safety will be compromised in case of Interoperability.

Key Issue: Quality of service

HSR requires top-class service; high-speed, frequency, punctuality and comfort from the view point of competition with airlines.

However under Interoperability, competitiveness of HSR will be decreased.

➤ Lower stability and longer journey time

Generally train operation on conventional lines is less stable due to its disadvantageous conditions such as existence of level crossings, too many passengers, too tight diagram and old-fashioned operation control system. Delay of conventional lines will affect high speed trains' operation. The tighter the conventional line's capacity is, the stronger its influence is.

Average operation speed on conventional lines might be less than 100 km/h, usually restricted about 60 km/h. Operation on a conventional line lengthens its journey time and that dims attraction of a high speed train.

➤ Restriction of high speed traffic frequency

Frequency of high speed trains is one of most important service character. When it is too low, time of waiting a train becomes long and that dims attraction of a high speed train.

Often it is the case that a conventional line has low track capacity due to outdated signaling system and there is little or a little spare capacity. Furthermore time zones for both passengers of high speed and conventional to use often overlaps. High speed trains need to share this little spare capacity with conventional trains and frequency of high speed trains shall be restricted.

➤ Seating comfort and passenger capacity

Seating comfort is one of important factor of HSR service. HSR requires top-class service and offers some-types of seat, wide seat, reclining chair, rotating seat and so on. However space of rolling stock is limited and it is not easy to achieve both high passenger capacity and seating comfort. Adopting wide-body type is one of solutions.

Key Issue: Technical compatibility of rolling stock

➤ Increase of rolling stock cost

Usually technical specifications and standards of a HSR line differ from those of a conventional line. Rolling stock needs to have technical compatibility for interoperability, such as track gauge, loading gauge, signaling system, power supply system and so on. Technical compatibility for interoperability results in increase of rolling stock cost.

For example, rolling stock needs to consider high level crush-worthiness for level crossings of conventional lines.

Javelin, British Rail Class 395, which can operate both on High Speed 1 and conventional lines have been equipped with compatibility of 2 types of power supply system, AC 25 kV-OHC and DC 750 V-3<sup>rd</sup> rail, and 4 types of signaling system, TVM, KVB, AWS and TPWS.

Lastly, on the assumption that high speed train operates into a conventional line via terminals-interoperability 2, available hours used for high speed operation will be decreased and the number of rakes for high speed train will become enlarged, resulting in increase of rolling stock cost.

(3) Advantages and disadvantages of adopting interoperability to Mumbai-Ahmedabad corridor

Particularly it will be examined how much interoperability effects on high speed train through the case study of Mumbai-Ahmedabad corridor. Of three alternatives, which are studied in Environment and Social Consideration, ALT1 and ALT2 are cases of HSR lines independent from conventional lines and ALT3 uses conventional lines in the vicinity of Mumbai, Surat, Vadodara and Ahmedabad. This case study is executed on this line, ALT3 (Figure 4.4-5).

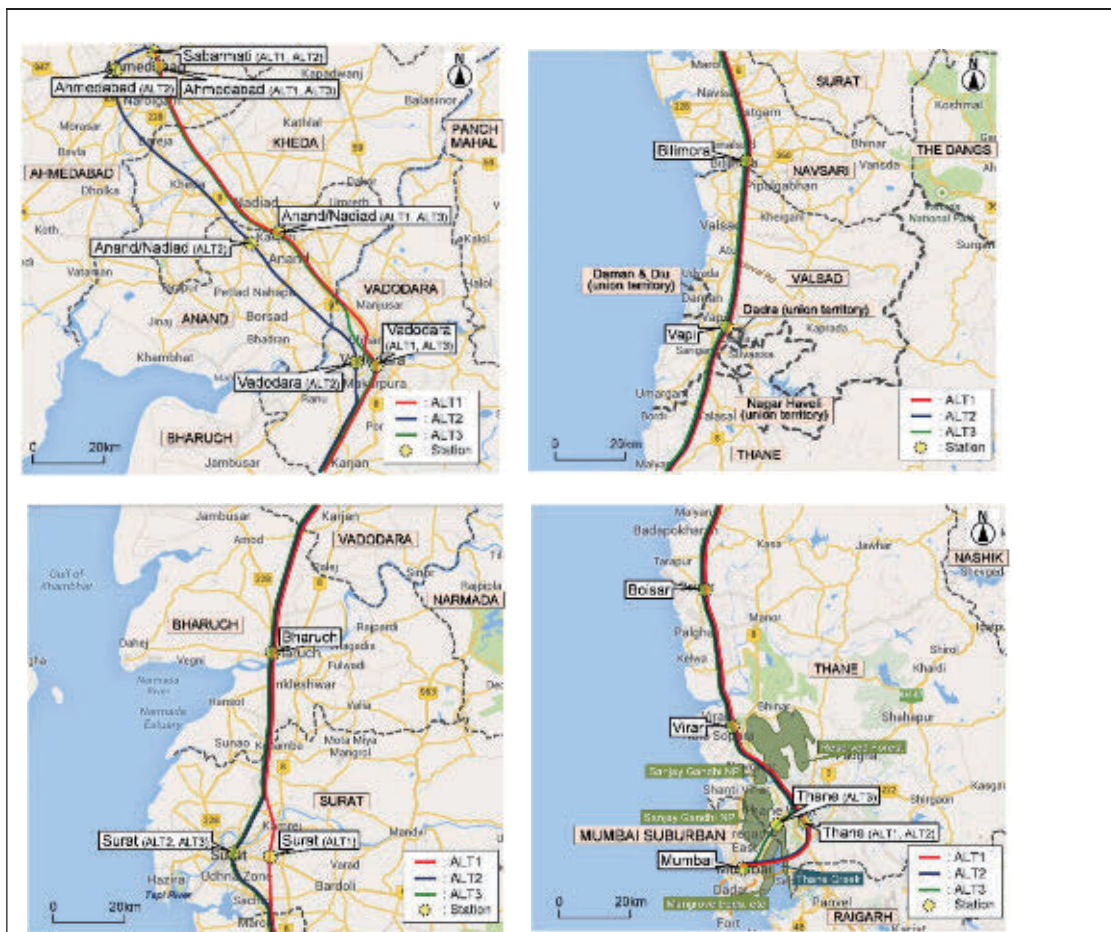

(Note)

- 1) In Mumbai area, ALT1 route is Tunnel case and ALT2 route is Viaduct/Bridge case
- 2) ALT3 route considers interoperability with existing railway line in Mumbai, Surat, Vadodara and Ahmedabad area.

Source: Compiled by Study Team

Figure 4.4-5 Route Alignment of ALT 3

Main advantages and disadvantages are shown in Table 4.4-2 as adopting interoperability in the Mumbai-Ahmedabad corridor.



Table 4.4-2 Main Advantages and Disadvantages of Adopting Interoperability in Mumbai-Ahmedabad Corridor

<b>Prerequisite for Interoperability</b>		
Line capacity		-Congested train operation of the conventional line -Conventional lines don't have enough spare line capacity -In order to operate HS train on the conventional line, existing train service will have be reduced
<b>Advantages and Disadvantages of adopting Interoperability</b>		
Advantages	Gauge, transfer and infrastructure	-Same gauge railway with the conventional lines -Utilizing existing infrastructure -No need to transfer ( under adopting Interoperability 2)
Disadvantages	Safety issue	-No signal back-up system except for the Auxiliary Warning System (AWS) in Mumbai Area -About 15 level crossings exist on the conventional lines -Safety will be compromised in case of Interoperability
	Less stability and longer journey trip	-The restricted speed of 60km/h on the conventional lines -HS trains' journey time will be prolonged from the planned 120 minutes to 170 minutes under interoperability - Delay of the conventional lines affects HSR operation
	Seat comfort and Passenger capacity	-Coach gauge of conventional lines is 3250 mm width -Wider coach gauge (3400mm) can provide a more comfortable service and ensure passenger capacity
	Increase of rolling stock cost	-Necessity to install AWS and high level crash-worthiness -Twice or triple number of train sets in case of extension to Pune by interoperability 2

Source: Study Team

➤ Prerequisite: Line capacity

ALT 3 is supposed that high speed trains operate on conventional lines near Mumbai, Surat, Vadodara and Ahmedabad. Schematic diagrams of lines are shown in Figure 4.4-6.

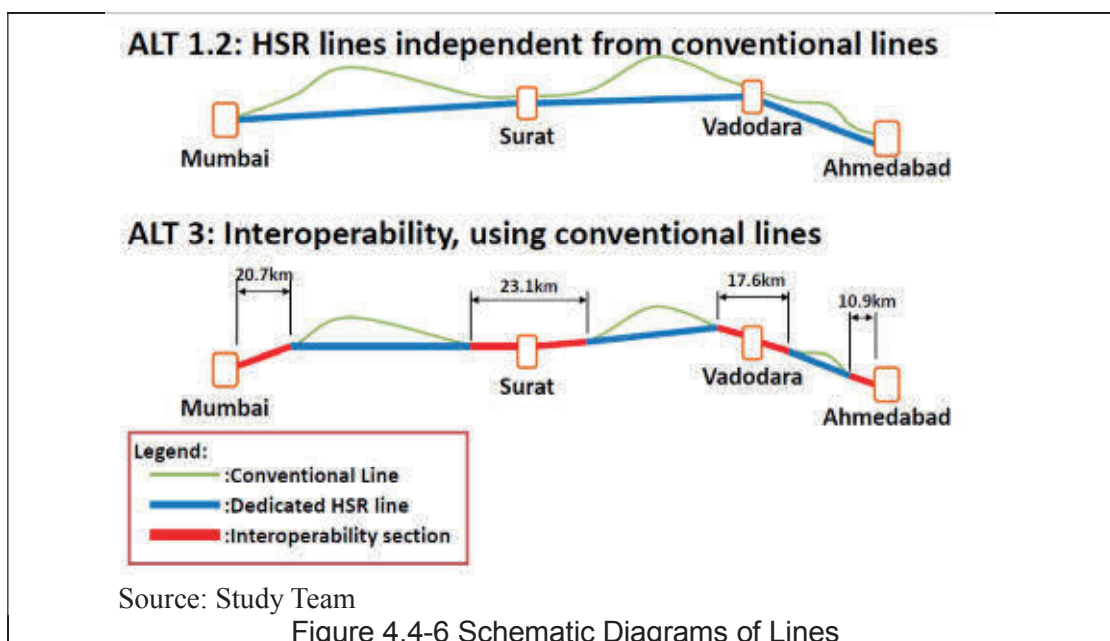

And Table 4.4-3 shows current situation of line capacities on related conventional lines.

Regarding Mumbai area, both Suburban line and Harbour line are for commuter, of which distance between stations is so short and train frequency is so high that they are not suitable for HS train operation. ALT 3 route is supposed to use main line. It has little spare line capacity. Actually additional line constructed and planned are mainly for suburban traffic in Mumbai. Also there is little spare line capacity in Surat, Vadodara and Ahmedabad area. In order to operate high speed train on conventional lines, frequency of conventional trains, which are congested even now, have to be reduced. It is not in a realistic way.

Table 4.4-3 Current Situation of Conventional Lines

Section	Line capacity ( pairs/day) (A)	Current situation ( pairs/day)			Line capacity usage(%) (B)/(A)
		Passenger	Freight & Others	Total (B)	
<b>Mumbai area</b>					
Main line] Dadar - Kurla	170	158	15	173	102
Suburban line] *1 Dadar - Kurla	328	265	3	268	82
Harbour line] *1 Chhatrapati - Vadala	240	256	3	259	108
<b>Surat area</b>					
Surat - Bharuch	83	72	36	108	130
<b>Vadodara area</b>					
Bharuch - Vadodara	83	71	36	107	129
<b>Ahmedabad area</b>					
Kunkariya - Ahmedabad	71	70	37	107	151

Note:

\*1. These lines are for commuter, and not suitable for high speed train operation.

\*2. These capacities are considering maintenance block.

Source: Compiled by Study Team based on IR's data

➤ Safety issue

Auxiliary Warning System (AWS) is only installed in the neighborhood of Mumbai as a back-up system other than an automatic signaling system and no buck-up system is installed in other areas. It is lower safety level than a HSR line in which a reliable back-up system usually installed.

Near Mumbai, Surat, Vadodara and Ahmedabad about 15 level crossings exist on the conventional lines on which high speed trains are supposed to operate. Therefore there remain some possibilities of accidents on level crossings.

➤ Less stability and longer journey trip

Delay of a conventional line affects directly high speed train operation, because conventional lines are being operated densely even now.

Operation on the conventional lines around Mumbai, Surat, Vadodara and Ahmedabad will be restricted its speed to under 60 km/h and thus journey time from Mumbai to Ahmedabad is prolonged from the planned 120 minutes to 170 minutes under interoperability mode.

➤ Restriction of high speed traffic frequency

As mentioned above, there is a little or little spare track capacity in relevant conventional lines. It would be almost impossible that high speed trains operate in a crack between conventional trains' operation. In order to operate high speed train on conventional lines, frequency of conventional trains, which are congested even now, have to be reduced. It is not in a realistic way.

➤ Increase of rolling stock cost

Realizing interoperability, high speed rolling stock needs to be equipped with AWS which is installed in Mumbai area in addition to a protection system of HSR line.

Crash safety is particularly important in the case of high speed trains running on lines with level crossings. The train should be built in a way that prevents death and injury from passengers and a driver. High-level crush-worthiness results in increase of rolling stock cost.

Besides them for the purpose of interoperability in India, development of high speed bogie, the gauge of which is inevitably broad-1676mm-, is required.

All these things would cause increase of rolling stock cost.

Furthermore on the assumption that high speed trains operate to Pune on a conventional line from Mumbai area, the journey time from Mumbai to Pune is from about 3 to 4 hours, while that from Mumbai to Ahmedabad is from about 2 to 3 hours. Thus twice or triple number of rakes would be required for operation at same frequency.

#### (4) Recommendation

Interoperability between a HSR line and a conventional line has advantages such as passenger convenience and possibility of reduction in infrastructure cost when a conventional line has enough spare line capacity. However there is not enough line capacity in relevant conventional lines.

Furthermore it has a lot of disadvantages such as safety issue, less stability, restriction of operation frequency and increasing rolling stock cost.

The study team strongly recommends adopting fully-dedicated HSR line in Mumbai-Ahmedabad corridor, which is constructed to be independent of conventional lines in consideration providing good connectivity between high speed and conventional lines.

#### 4.4.2 Gauge Selection

##### (1) History of Track-gauge in Indian

###### 1) Birth of standard-gauge

The track-gauge, 1,435 mm (4ft 8in), which is now called the standard-gauge, was adopted by (1) “The Stockton and Darlington Railway,” that was opened in 1825 in UK and is now referred to as the first public railway in the world, and (2) “The Liverpool and Manchester Railway,” a railway that started passenger transport service first in the world.

Whereas manual trucks and horse-drawn carriages were used for transport in coal mines before advent of these railways, locomotives developed and designed to have the same track-gauge as that of trucks by Stephenson were introduced to erstwhile used primitive transport means. At their construction, “The Stockton and Darlington Railway” and “The Liverpool and Manchester Railway” adopted locomotives developed by Stephenson for coal mines, which inevitably resulted in the adoption of 1,435 mm track-gauge by railways that followed.

###### 2) Development of broad track-gauges

The 1,435 mm track-gauge was adopted even thereafter successively by other railways that used locomotives developed by Stephenson. In constructing new railways, however, the concept to adopt the 1,435 mm track-gauge gave way to a newly emerged way of thinking. In view of the fact that (1) it is by no means inevitable to adopt the gauge stemmed from horse-drawn carriages and (2) the broader the track-gauge is, the larger boilers can be mounted on locomotives to exert larger hauling power, a railway was constructed to have a track-gauge larger than 1,435 mm, in that The Great Western Railway adopted a track gauge of 7 ft. 1/4 in. (2,140 mm).

In India, a 34 km-long railway was opened to connect Bombay (Mumbai) and Thane in 1.25 hours in 1853 as the first railway in the country. This railway adopted a broad-gauge (1,676 mm) according to the opinion of the then Governor-general of India “the broader the track-gauge, the better” and in consideration of the fact that through-operation with British and other existing railways wasn’t required and locomotives for broader track-gauges were able to exert larger power. After that, the railway network in India expanded step by step to reach the present scale of exceeding 64,460 km.

###### 3) Construction of narrow-gauge railways

In India, (1) “The Gaekwad Baroda State Railway” was opened in the suburbs of Baroda in 1862 as the first narrow-gauge railway in the country and (2) “The Rajputana-Malwa Railway” started revenue service in 1873 as the first meter-gauge railway in the country with a 84 km-long main line between Delhi and Rewari and a 12.3 km-long branch line. Railways constructed in those days include those constructed by Maharajas and indigenous capitalists with their own funds and those carrying low traffic volumes in local areas. To cut the construction cost, their railways adopted the narrow-gauge of 1,000 or 762 mm.

As a result, there are different track-gauges, standard-gauge, meter-gauge and narrow-gauges in India (Table 4.4-4).

Table 4.4-4 Route Length Classified by Track-gauge (as of March 2012)

Gauge	Route Km
Broad Gauge (1,676 mm)	56,956
Meter Gauge (1,000 mm)	6,347
Narrow Gauge (762,610 mm)	2,297
Total	64,600

4) Unification of track-gauges

As railway networks expand to make railways of different track-gauges come across at the boundary between two different track-gauges, differences in track-gauge have become increasingly problematic to require passengers' changing trains and freight transshipment at track-gauge breach points.

After India become independent, Indian Railways, while possessing whole railway networks in the country under its umbrella, has promoted conversion of track-gauges centering on main lines, mostly into the 1,676 mm track-gauge, at a pace of approx. 850 km/year. According to its long-term plan, Indian Railways intends to convert 12,000 km-long railways except mountain climbing railways and those specified as a world heritage into broad-gauge railways by 2020.

## (2) Gauges for HS operation

Bogie and axels are one of most important items for high speed rolling stock. They affect directly riding stability of high speed trains and a defect of them might cause a fatal accident. Broad gauge-1676 mm-is used for main lines in Indian Railways and it is unique in the world.

Figure 4.4-7 shows ratio of gauge types for high speed operation. Train operation at maximum speed of 250 km/h on broad gauge is only realized in Russia and operation over 300 km/h on broad gauge has not been realized in the world.

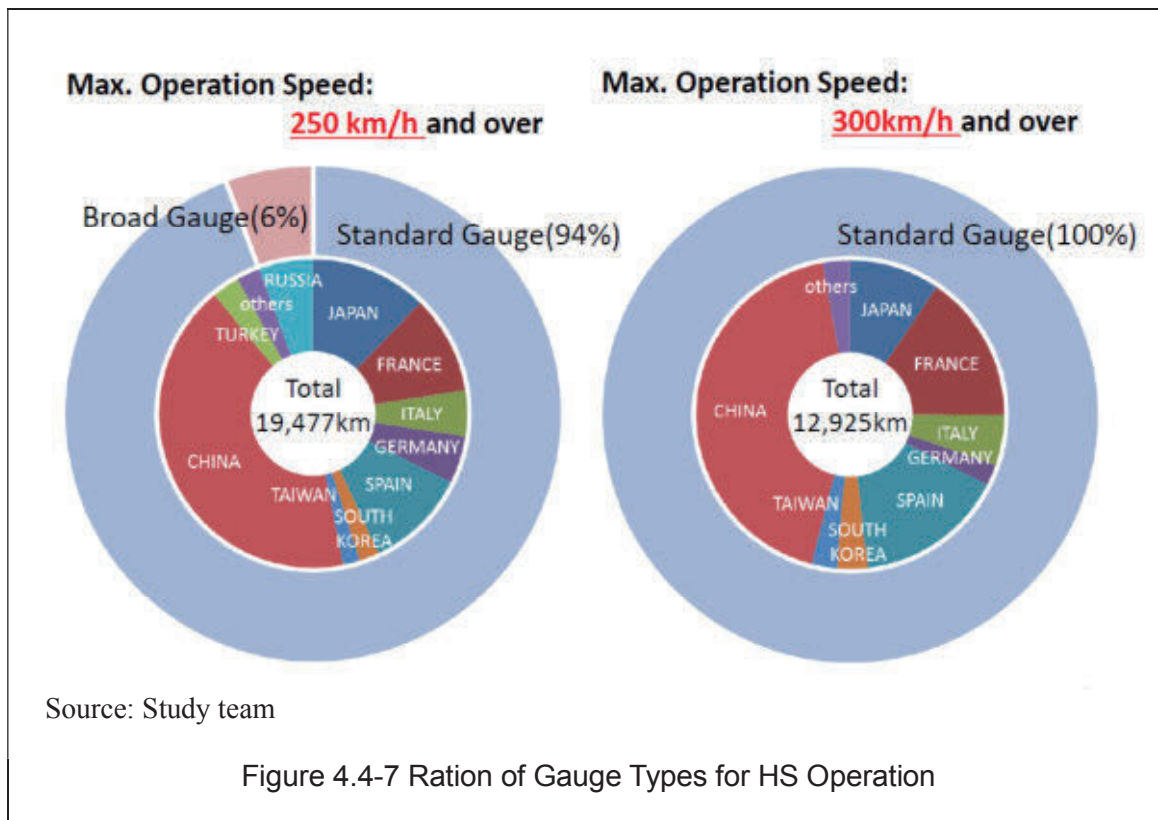

## (3) High speed operation on broad gauge

Although some countries such as Russia and Spain operate over 200 km/h on broad gauge, each line is an upgraded conventional line.

### ➤ Russia

Track gauge of conventional lines in Russia is 1520mm, a little wider than standard gauge. High speed trains have been operating at maximum speed of 250 km on up-graded conventional lines since 2009.

### ➤ Spain

Track gauge of conventional lines in Spain is 1668mm, which is almost same as that in India. Spain planned to construct HSR until the Expo 1992 in Sevilla, and has decided HS line should be constructed at a standard gauge due to utilizing proven technology for realizing HSR in short term.

New HSR lines have been constructed at standard gauge and some conventional lines are being upgraded for over 200 km/h operation. Maximum operation speed on conventional lines-broad gauge- remains at 220 km/h, while maximum operation speed has been reached at 300 km/h on new HSR lines-standard gauge.



As stated earlier, the maximum operation speed on broad gauge is 250 km/h. Therefore realizing operation speed over 250 km/h on broad gauge requires development of HS rolling stock. Track gauge directly affect bogie system, which is one of the most important sub-system about rolling stock. When broad gauge is adopted, an axel and a bogie frame will be extended. That will cause change of the movement between a rail and a wheel. It will reflect stability of HS trains' operation. And increasing weight of axels and bogies will give bigger stress to rail and track. Influence of the stress needs to be analyzed. Confirming these things will take pretty long term and cost for inspection and verification.

#### (4) Recommendation

Today standard gauge; 1435mm is commonly used for HSR in the world and all of new constructed HSR lines are standard gauge at the moment. (Table 4.4-5) International market of HSR is based on standard gauge.

Table 4.4-5 Current Situation of World HSR

Country	Year, the first operation	Maximum speed (km/h) (at the time of the first operation)	Maximum speed (km/h) (up to now)	Distance (km)	Track gauge (mm)
Japan	1964	210	320	2388	1435
France	1981	260	320	2036	1435
Italy	1988	250	300	923	1435
Germany *1	1991	250	300	1334	1435
Spain	1992	250	300	2515	1435
Belgium	1997	300	300	209	1435
United Kingdom	2003	300	300	113	1435
South Korea	2004	300	300	412	1435
Taiwan	2007	300	300	345	1435
Switzerland	2007	250	250	35	1435
China	2008	350	*2 300 (350)	9867	1435
Turkey	2009	250	250	444	1435
The Netherlands	2009	300	300	120	1435
Austria	2012	230	250	93	1435

Note:

\*1. Include ABS; up-graded line, of which maximum operation speed is 230 km/h

\*2. The maximum operation speed was reduced from 350 km/h down to 300 km/h in 2011

Source; Compiled by Study team based on UIC data

On broad gauge, only 250 km/h is proven in the world at the moment, while that on standard gauge is over 300 km/h. Therefore realizing operation speed over 250 km/h on broad gauge, development of rolling stock, especially bogie and axels, is necessary. Broad gauge-1676 mm-is unique in the world, so the development should be done on Indian railways' own way.

And in the future, when Indian Railways would intend to manufacture in India and export HSR technology to other countries, it would not be easy due to the difference of gauges.

These are technical disadvantages of adopting broad gauge to HSR because international market of HSR is based on standard gauge.

Therefore it should be recommended that a HSR line adopts standard gauge (1435mm).

#### 4.5 Required Levels on Services / Facilities

##### 4.5.1 Maximum Operation Speed

###### (1) Current situation and analysis

Table 4.5-1 shows Maximum operation speed of high-speed train in major countries.

Table 4.5-1 Maximum Operation Speed of HSR in the World

Country	Japan	France	Italy	Germany	Spain	South Korea	Taiwan	China
Maximum Operation Speed ( km/h )	320	320	300	300	300	300	300	300 (350)

Maximum operation speed of the major countries in the world is from 300 to 320kmph. In China, high speed trains operated at 350km/h for a period time, however the maximum operation speed has been reduced and it is 300 km/h today.

It can be said that maximum operation Speed, at which HSR operate stably and continually, is 320kmph at present. Figure4.5-1 shows Air / Train market share of typical sections, where HSR operates, in the world. This figure is the UIC-study's result.

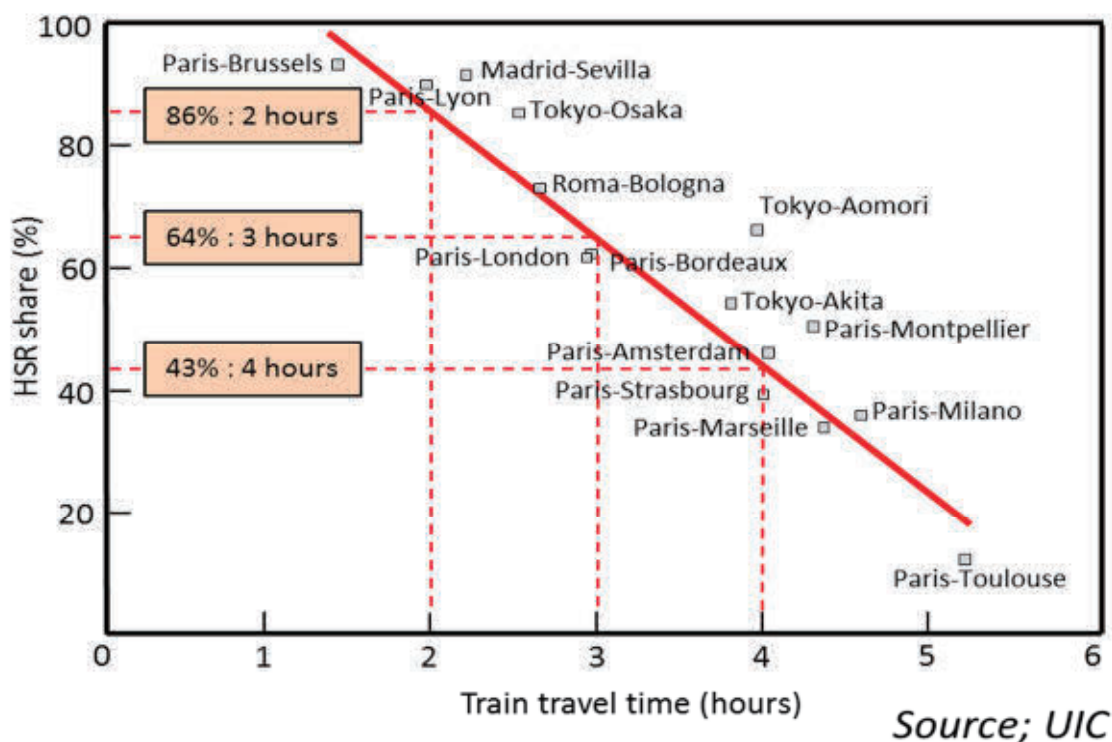

Figure4.5-1 Air / Train Market Share in the World by Train Travel Time

According to Figure4.5-1, the share of the Train to the Air becomes higher as much as the train travel time becomes short. If train travel time is from 3 hours to 3.5 hours, the share of the train exceeds the share of the airplane. On condition that Train travel time is within 3 hours, HSR's share is dominant. And within 2.5 hours, that is overwhelming. As much as train travel time

becomes shorter, the share of HSR becomes higher. Therefore, it is necessary to set the HSR train so that arrival time is less than 3 hours or 3.5 hours to do competition with the airplane profitably. From the view point of this fact, maximum operation speed should be considered.

The distance from Mumbai to Ahmedabad, which is studied in this project, is approximately 500km. If the maximum speed is more than 300km/h like that usually applied in major countries, it is possible to achieve within 3 hours from Mumbai to Ahmedabad. If train travel time becomes shorter, the superiority of the HSR train becomes higher.

(2) Recommendation

Based on MOU between JICA and MOR and analysis mentioned above, required service levels and technical standards of Maximum design speed and Maximum operation speed will be 300-350 km/h in this study. Actually it should be recommended that it will be 320 km/h at inauguration and be increasing to 350 km/h, while confirming safety operation.

4.5.2 Traffic Frequency

➤ Required Minimum Traffic Frequency

It is required to consider both train travel time and waiting time for convenience of passenger. On the next stage, the minimum traffic frequency of the rapid-type train and each-stop type train will be considered based on demand forecast.

➤ Required Maximum Traffic Frequency

The study route, between Mumbai and Ahmedabad, is around 500km and has metropolitan cities at both ends and large cities in between. The condition of this route is similar to Japanese Tokaido-Shinkansen case which has the most traffic frequency and passenger transport in the world.

Figure 4.5-2 shows the Change of Number of Trains per hour in the Tokaido Shinkansen the frequency of which is most of HSR in the world.

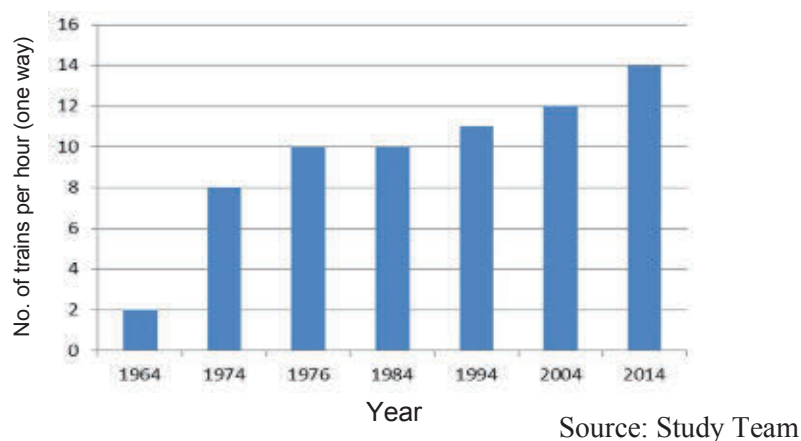

Figure 4.5-2 Change of Number of Trains per Hour in the Tokaido Shinkansen

At present, maximum traffic frequency is 14 trains per hour in the Tokaido Shinkansen.

### 4.5.3 Countermeasures against Earthquakes and Natural Disasters

#### (1) Measures against earthquakes

##### 1) Present situation

The Indian government has created a Seismic Zonation Map as shown in Figure 4.5-3. According to this seismic risk map, Arabian Sea coastal areas in the central part of Maharashtra State and the western part of Gujarat State are classified as the high-risk Zone-IV and Zone –V areas. (see Table 4.5-1) The project area of the proposed route may experience major earthquakes. Therefore effective measures against earthquakes are essential for this project. Since it is nearly impossible to predict when a major earthquake will occur, it is necessary to minimize the damage. Structures must bear its seismic power and trains must stop automatically as soon as a major earthquake hits. Furthermore if it would be possible, a train could prevent derailment and turnover until its emergency stop.



Source: Map of India

Figure 4.5-3 Distribution of Seismic Zones

Table 4.5-1 Classification of Seismic Risk

Seismic Zone	Intensity on Modified Mercalli scale
II	Low intensity zone
	VI (or less)
III	Moderate intensity zone
	VII
IV	Severe intensity zone
	VIII
V	Very severe intensity zone
	IX (and above)

Source: INDIA METEOROLOGICAL DEPARTMENT Homepage

## 2) Case study in Japan

The efforts against the disasters caused by earthquakes have been made in Japan based on the policy contains 3 points below:

1. Not to be destroyed by earthquakes ... Seismic design of civil structures
2. To stop the train earlier ... Early Earthquake Detection System
3. To minimize damage of derailment occurred by any possibility ... Protection System to prevent the train deviation from the rail line.

To construct HSR in Maharashtra and Gujarat state where the occurrence of huge earthquakes is anticipated, it is highly recommended to adopt experience of seismic design.

### i) Seismic design of civil structures

Strict seismic design standard had been instituted in Japan where so many earthquakes occur and it has been much developed since the Great Hanshin Earthquake occurred in 1995.

The Japanese train operators have made efforts in construction of new lines and reinforcement of existing structures to comply with the strict standard.

### ii) Early Earthquake Detection System

Shinkansen Early Earthquake Detection System is to minimize damage from an earthquake by the early earthquake detection system.

The mechanism of Shinkansen Early Earthquake Detection System is

1. To detect the primary wave by the detector installed at certain places.
2. To send the order to the certain electric power substations which transmit electric power to Shinkansen to stop transmitting electric power to Shinkansen.
3. Emergency brake of Shinkansen starts functioning by shutoff of electric power transmission.

The 27 Shinkansens running on Tohoku Shinkansen when the Great East Japan Earthquake (March, 2011) occurred safely stopped by the Early Earthquake Detection System.

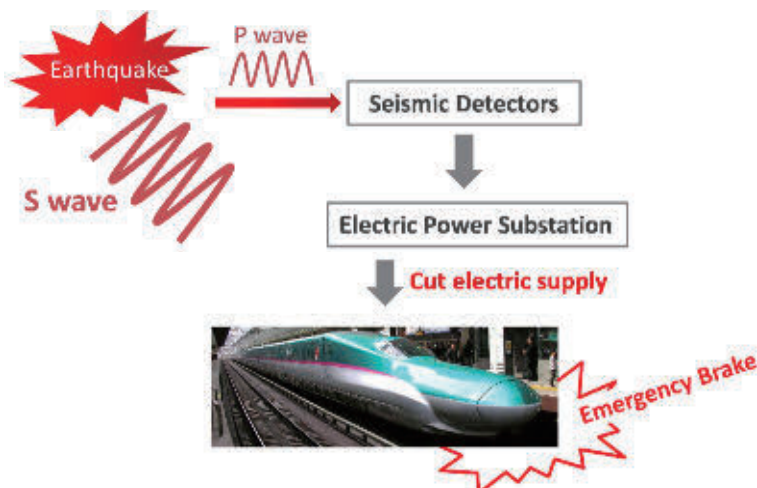

Figure 4.5-4 Mechanism of Early Earthquake Detection System

### iii) Rolling Stock Guide Mechanism

It is the mechanism to prevent the train from deviating too far from the rails after a derailment.

A car guide mechanism shaped like a backwards “L” is installed under the bogie axle box, and if the car derails, it prevents the wheels from moving sideways more than a set amount.

(2) Measures against natural disasters

1) Present situation

A high speed train needs a considerable braking distance. For example a train running over 250 km/h runs over 3 km even when the emergency brakes are applied. It is usually too late when the driver detects some malfunction on the tracks ahead. Therefore measures against natural disaster are absolutely necessary. Especially the project areas are belonging in tropical monsoon climate, tropical savanna climate or semiarid climate, where it rains considerably much in rainy season (see Figure 4.5-5, 4.5-6 and 4.5-7). In addition the proposed route will pass through the areas, the soil of which is black cotton soil and its physical properties change substantially according to its moisture content. Therefore some rainy disasters will be expected.

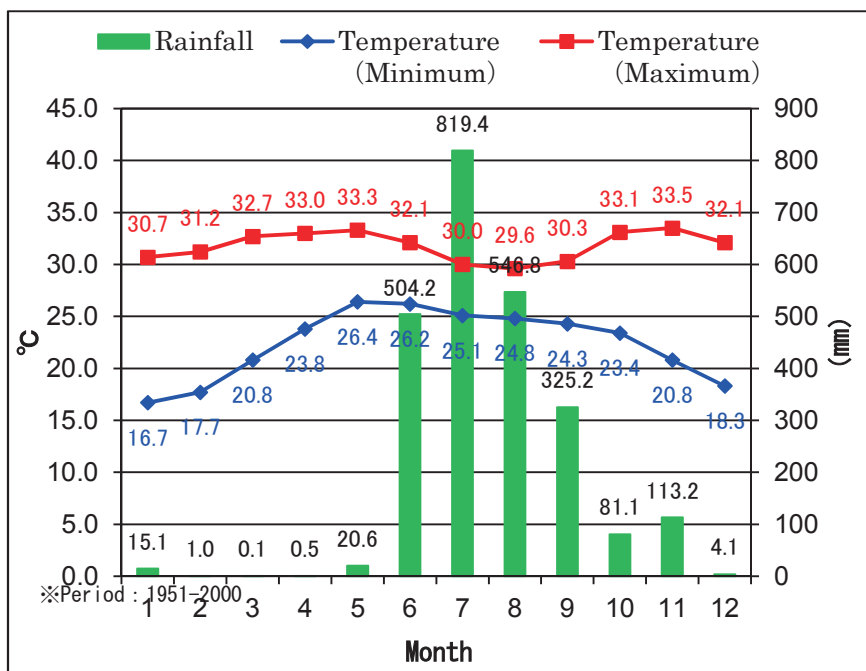

Source: Compiled by Study Team based on INDIA METEOROLOGICAL DEPARTMENT material

Figure 4.5-5 Temperature and Precipitation (Mumbai)



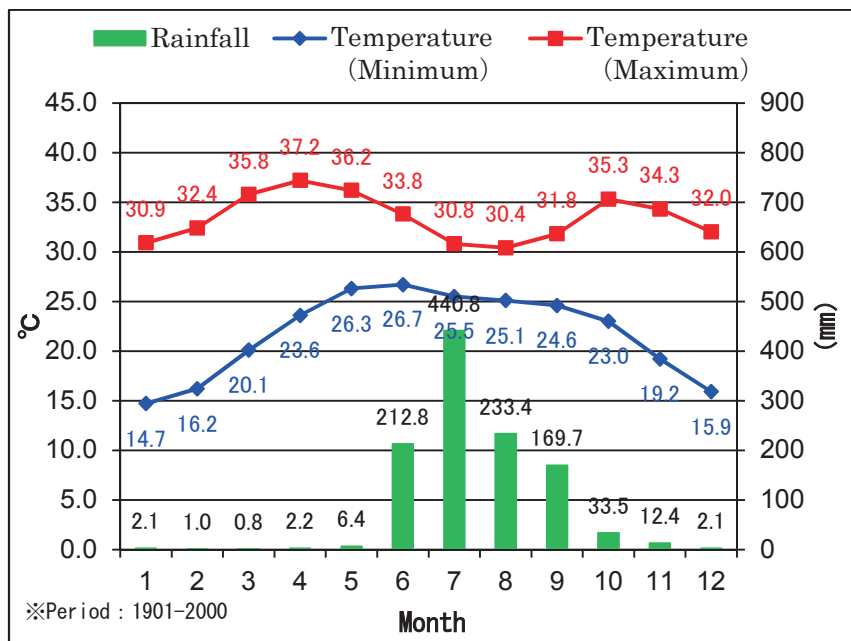

Source: Compiled by Study Team based on INDIA METEOROLOGICAL DEPARTMENT material

Figure 4.5-6 Temperature and Precipitation (Surat)

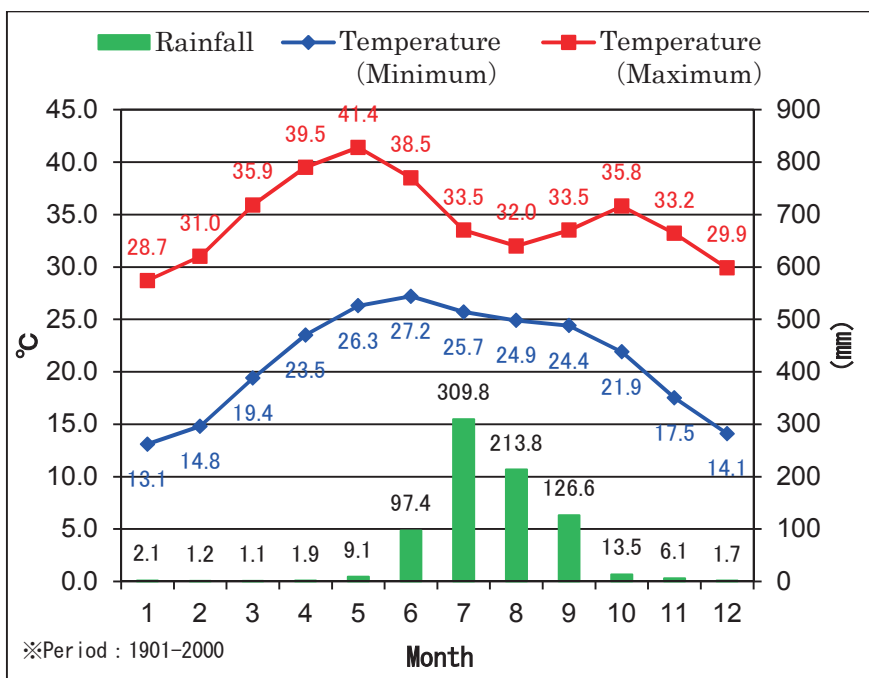

Source: Compiled by Study Team based on INDIA METEOROLOGICAL DEPARTMENT material

Figure 4.5-7 Temperature and Precipitation (Ahmedabad)

## 2) Recommendation

Natural disasters caused by rainfall are likely to lead to train accidents by destroying civil structures and forcing train operation in the hard condition, etc.

For such situation, countermeasures against the disasters caused by rainfall have been developed in Japan. These countermeasures are highly recommended to HSR in India.

### i) Civil structure reinforcement against natural disasters caused by rainfall

Continuous rainfall sometimes causes the destruction of soil structures such as embankment structure, cut structure and entrance of tunnel structure, etc.

To prevent the disasters, such soil structures have been reinforced by adopting the installation of concrete frames on embankment section, wall to prevent landslide on cut section and cover structures on the entrance of tunnel to prevent landslide.

### ii) Train Operation Control under heavy rainfall

To prevent the train accidents from the disasters caused by rainfall, Japanese train operators have developed their train operation control under rainfall by the method below:

1. Setting the threshold value of accumulated rainfall in each certain sections
2. Accumulated rainfall is monitored by the precipitation gauge installed in each section.
3. When the measured accumulated rainfall exceeds the threshold value in a certain section, the order to restrict the train to enter into the section.

#### 4.6 Basic Technical Standard and System Selection

In this section, Recommendations of basic technical standard and system selection are described, comparing world's HSR technology shown in the table 4.6-1, 4.6-2.

Table 4.6-1 General and Civil-related Specifications

	Japan	France	Italy	Germany	Spain	South Korea	Taiwan	China
First Inauguration year	1964	1981	1988	1991	1992	2004	2007	2008
Track Gauge (mm)	1,435	1,435	1,435	1,435	1,435, 1,668	1,435	1,435	1,435
Minimum Curve Radius (m)	2,500-4,000	4,000-6,250	5,400	4,000-4,670	4,000	7,000	6,250	4,000-9,000
Maximum Gradient (%)	35	35	8.5	40	12.5	15	25	35
Maximum Axle Load (t) (design)	16.0-17.0	17.0	17.0	16.0-19.5	17.2	17.0	25.5	20.0
Distance between Track Center(m)	4.2-4.3	4.2-4.8	5.0	4.5-4.7	4.3-4.7	5.0	4.5	5.0
Formation Width (m)	10.9-11.7	13.6-14.2	13.0	12.1-13.7	13.3	14.0	13.0	13.4-13.8
Cross Section of Double-Track Tunnel (m <sup>2</sup> )	62.8-63.5	71-100	76	82-92	75	107	90	90-100
Track Structure	Ballasted/ Ballastless	Ballasted	Ballasted	Ballasted/ Ballastless	Ballasted	Ballasted/ Ballastless	Ballasted/ Ballastless	Ballasted/ Ballastless

\*upgraded conventional line for H.S. operation

Source: UIC, Study Team

Table 4.6-2 Specifications for Rolling Stock, Power Supply System and Signalling

	Japan	France	Italy	Germany	Spain	South Korea	Taiwan	China
Rolling stock type	EMU	Loco	Loco/EMU	Loco/EMU	Loco/EMU	Loco	EMU	EMU
Car Body Width (mm)	3,350 - 3,380	2,814 - 2,904	2,750 - 3,000	2,950 - 3,020	2,830 - 2,960	2,904 - 2,970	3,380	3,200 - 3,380
Maximum Operation Speed	320 km/h	320 km/h	300 km/h	300 km/h	300 km/h	300 km/h	300 km/h	300 km/h
Typical series	E5	TGV-R	AGV	Velaro403	S103	KTX-II	700T	CRH380A
Body-material	Aluminium	Steel	Aluminium	Aluminium	Aluminium	Aluminium	Aluminium	Aluminium
Power / Seat (kW/seat)	13.13	23.47	16.67	18.65	21.84	24.24	10.37	20.00
Power Supply	AC 2x25kV (AT)	AC 2x25kV (AT)	AC 2x25kV (AT)	AC 1x15kV (Simple)	AC 2x25kV (AT)	AC 2x25kV (AT)	AC 2x25kV (AT)	AC 2x25kV (AT)
Overhead Catenary	Heavy Compound/ Simple Catenary	Simple Catenary	Twin Simple Catenary	Stitched Catenary	Stitched Catenary	Simple Catenary	Heavy Compound Catenary	Simple/ Stitched Catenary
Signal Type	Cab Signal Continuous	Cab Signal Continuous	Cab Signal Continuous	Cab Signal Continuous	Cab Signal Continuous	Cab Signal Continuous	Cab Signal Continuous	Cab Signal Continuous
Denomination of main Train Protection System	Digital-ATC	TVM430 ETCS L2	ETCS L2	LZB ETCS L2	LZB ETCS L1, L2	TVM430 ETCS L1	Digital-ATC	CTCS L3

#### 4.6.1 Schedule of Dimension for Mumbai-Ahmedabad High Speed Railway Corridor

##### (1) Overview of SOD for HSR

###### 1) Role of SOD

What is called Schedule of Dimension (SOD) in India is called such as ‘Construction gauge’ or ‘Construction standard’ in other countries. SOD is a schedule, which lays down some of limiting values and recommendation for track tolerance, location of structure, construction standard and rolling stock parameters.

SOD is the most important characteristic which defines the railway lines. It is through the SOD, safety of operation in the case of different types of trains on the lines of the same SOD can be secured. Moreover it affects construction cost greatly. Therefore it needs to be decided before construction of the line, considering roles or connectivity of the line.

###### 2) Global comparison of SOD

Table 4.6-3 shows comparison of Main characters, which includes maximum operation speed, formation width, minimum curve radius and so on, of SOD for HSR across the globe. SOD varies greatly from one country to another. In this table it is recognized that Japanese Shinkansen operates wide body trains on the most compact infrastructure, of which one typical dimension is tunnel cross section. Shinkansen’s 63 m<sup>2</sup> is almost two-thirds of that of 100 m<sup>2</sup> in French or China.

Table 4.6-3 Comparison of SOD for HSR

Country	Japan	France	Italy	Germany	Spain	South Korea	Taiwan	China
First operation (year)	1964	1981	1988	1991	1992	2004	2007	2008
Max. Op. speed (km)	320	320	300	300	300	300	300	320
Width-R.S gauge (mm)	3380	2904	3000	3020	2960	2970	3380	3380
Distance between track centers (m)	4.2 ~4.3	4.2 ~4.8	5.0	4.5 ~4.7	4.3 ~4.7	5.0	4.5	5.0
Formation width (m)	10.9 ~11.7	13.6 ~14.2	13.0	12.1 ~13.7	13.3	14.0	13.0	13.4 ~13.8
Mini. curve radius (m)	2500 ~4000	4000 ~6250	5400	4500 ~4670	4000	7000	6250	4000 9000
Tunnel cross section (m <sup>2</sup> )	62.8 ~63.5	71 ~100	76	82 ~92	75	107	90	90 ~100
Maximum gradient (‰)	35	35	8.5	40	12.5	15	25	35

Source Study team

###### 3) Historical transition of Shinkansen’s SOD

Even in one country, SOD is reorganized with the passage of time. Historical transition of SOD in Japanese Shinkansen is shown in table 4.6-4. In Japan, there was a ‘‘Bullet Train Project’’ before World War 2, which was not realized. This project was based on steam locomotive (SL) or direct current (DC) technology. It applied standard gauge and wide rolling stock gauge almost same as that of Shinkansen.

Table 4.6-4 Comparison of SOD for HSR

High Speed Line		Bullet Train Project	Tokaido	Sanyo	Tohoku/Joetsu	Hokuriku/Kyusyu
Service open year		*1 (1940)	1964	1972	1982	1997~
Max. Design speed (km/h)		150	210	260	←	←
Max. Operation speed (km/h)		Not realized	285	300	320	260
Rolling stock Gauge (mm)	Height (mm)	4800	4500	←	←	←
	Width (mm)	3400	←	←	←	←
Structural Gauge (mm)	Height (mm)	5150	7700	←	←	←
	Width (mm)	4400	←	←	←	←
Min. curve radius (m)		800	2500	4000	←	←
Max. cant (mm)		160	200	180	200	←
Max. cant deficiency (mm)		N.A	90	←	←	←
Max. gradient (‰) *2		10	15	15 (18)	15	15 (35)
Horizontal curve radius (m)		5000	10000	15000	←	←
Distance between track centers (m)		4.2	←	4.3	←	←
Formation width (m)		10.2	10.7	11.6	10.8	←
Tunnel cross section (m <sup>2</sup> )		N.A	63.5	←	63.4	62.8
Max. axel load		25	16	16	17	16

Note: \*1 ( ) Project start year, \*2( ) Exceptional case

Source Study team

When Shinkansen project was decided in November, 1957, main items of SOD, which is called as ‘Construction Standard’ in Japan, was formulated by April, 1958 within half year, considering not only conventional railway technology in the world but also prospect of technology development. Then construction of the line was implemented and operation started from 1964 after 6 years.

Also it should be remarked that current maximum operation speed can be over maximum design speed at the date of construction. For example, on the Tokaido line, which was constructed aiming at 210 km/h maximum operation speed and therefore has small radius curves, however current maximum operation speed has reached 285 km/h now through adopting Digital ATC signaling system, which composes continuous control system with one-step brake supervision function, and tilting system and high acceleration/ deceleration performance equipment into rolling stock.

On the other hand, formation of rolling stock and structural gauge has not been changed, that is because these dimensions are most crucial and decide whether rolling stock can operate on the line.

## (2) Prioritization of items in SOD for Preliminary Alignment Survey

### 1) Review of conventional SOD in India

Revised SOD 2004 consists of Schedule 1 and Schedule 2. Schedule 1 is a main component, which describes items mandatory on 1676 mm gauge. They are described in two-divided works, existing works and new works. Schedule 2 contains the existing infringement of Schedule 1.

Table 4.6.-3 shows items described in conventional SOD. In the first chapter ‘General’, basic dimensions in main lines such as Spacing of Tracks, Curves, Bridges, Building and Structures, Formation width are prescribed. In other chapters, dimensions in Station Yards, Workshop and Sheds of Rolling stock are prescribed.

## 2) Prioritization of items

These items described in conventional SOD have prioritized for Preliminary Alignment Survey, and classified into three ranks, A) items necessary for finalizing basic alignment, B) items necessary for basic design of infrastructure and systems, C) items unnecessary for HSR. These classifications are also remarked in Table 4.6-5 as priority for HSR. In the following section, no fewer than A) rank items will be dealt with.

Table 4.6-5 Items of Conventional SOD (Revised SOD 2004) in India

Chapter	Items	Priority for HSR
<b>Chapter I</b>	<b>General</b>	
	Spacing of tracks	A
	Curves	A
	Bridges	B
	Rails	B
	Buildings and structures	A
	Interlocking and signal gear	B
	Tunnels	B
	Safety Refuges	B
Formation width	A	
Gauge on straight on curves	B	
<b>Chapter II</b>	<b>Station Yards</b>	
	Spacing of tracks	A
	Plat forms	A
	Buildings and Structures	A
	Points and crossings	B
Length of sidings	B	
<b>Chapter III</b>	<b>Workshops and Station machinery</b>	
	Water tanks and cranes	C
	Workshops and running sheds	B
Ashpits etc.	C	
<b>Chapter IV(A)</b>	<b>Rolling stock(Carriage &amp; wagon) &gt;&gt;&gt;&gt;&gt;Rolling stock (HSR)</b>	
	Height of Floors	A
	Buffers & Coupling	B
	Wheel Base & Length of Vehicle	B
	Maximum Moving Dimensions	B
Loading Gauge for Goods >>>>>> Loading Gauge	A	
<b>Chapter IV(B)</b>	<b>3660mm wide stock &gt;&gt;&gt;&gt;&gt;&gt; Included in (A)</b>	C
<b>Chapter IV (C)</b>	<b>Locomotive &gt;&gt;&gt;&gt;&gt;&gt; Included in (A)</b>	C
<b>Chapter V</b>	<b>Electric-traction(Direct Current)</b>	C
<b>Chapter V-A</b>	<b>Electric-traction(25 KV AC. 50 Cycles)</b>	B
<b>Schedule II</b>	<b>Existing infringement of Schedule 1 which may be permitted to continue on existing 1676 mm gauge railways</b>	C
<b>Appendix</b>	<b>Note on Extra Clearance on Curves</b>	B

Note: Priority    A: Necessary for Finalizing Basic Alignment  
                       B: Necessary for Basic Design of Infrastructure and Systems  
                       C: Unnecessary for HSR

Source: Study Team



#### 4.6.2 Proposed Primary SOD for Mumbai-Ahmedabad High Speed Railway Corridor

##### (1) Outlines

Based on review of global SOD for HSR and conventional SOD in India, primary SOD for the initial HSR line, Mumbai-Ahmedabad Corridor, is being recommended. Recommendation is shown in Table 4.6-6 and Fig. 4.6-1

In the Joint Monitoring Committees of Mumbai-Ahmedabad HSR Corridor, main line characteristics are discussed, including 1) fully dedicated line independent from conventional lines: because of constraint of traffic capacity and safety issues, 2) standard gauge: proven and dominant in the world HSR, 3) wide-body EMU; realizing high passenger capacity, 4) maximum design speed is 350 km/h for the future possibility.

On these premises, recommendations are formulated. Each value is selected, considering conditions and status in India based on Shinkansen's experience.

For example regarding formation of Loading gauge and Structural gauge, wide type based on Japanese Shinkansen is selected as explained in the following section. However distance between track centers is 4500 mm, which is 200 mm wider than that in Japan.

Table 4.6-6 Proposed Primary SOD for Mumbai-Ahmedabad HSR

NO.	Items	Dimensions
(1)	Loading Gauge	Figure 4.6-1
(2)	Structure Gauge	Figure 4.6-1
(3)	Minimum Distance of Track Centre	4,500 mm
(4)	Width of Formation Level	11.5 m
(5)	Maximum Cant	$C_m=180$ mm
(6)	Maximum Cant Deficiency	$C_d=90$ mm
(7)	Horizontal Curves Radius for Speed of 350km/h	6000 m
(8)	Minimum Vertical Curve Radius	25,000 m
(9)	Maximum Gradients (Main Line)	Desirable 1 in 67 (15/1000) Maximum 1 in 40 (25/1000)
	Maximum Gradients (Depot Connecting line)	1 in 33.3 (30/1000)
	Maximum Gradients (Station Yard)	1 in 333.3 (3/1000)
(10)	Shape of Transition Curve	Sine Half-Wavelength Diminishing Tangent Curve
(11)	Transition Length ( $V \geq 160$ km/h)	Maximum of L1, L2, L3 $L1=1.0 \cdot C_m$ $L2=0.0097 \cdot C_m \cdot V$ $L3=0.0117 \cdot C_d \cdot V$ $C_m$ : amount of cant (mm) $C_d$ : cant deficiency (mm) $V$ : maximum design speed (km/h)
	Transition Length ( $V < 160$ km/h)	Maximum of L1, L2, L3 $L1=0.8 \cdot C_m$ $L2=0.0062 \cdot C_m \cdot V$ $L3=0.0075 \cdot C_d \cdot V$
(12)	Turnouts for Main Line	1 : 18 Turnout with movable nose crossing
	Turnouts for Depot	1 : 9

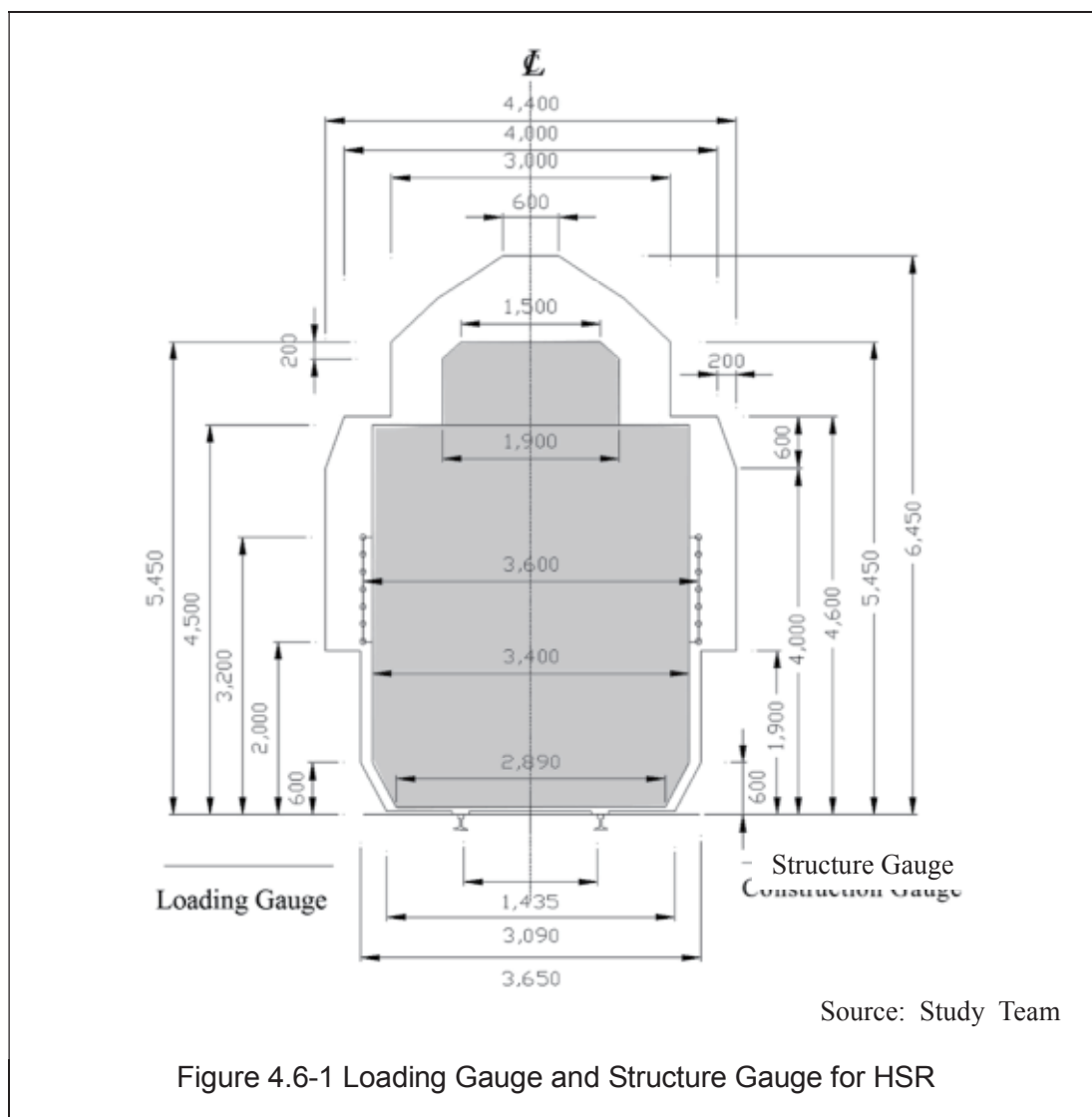

Figure 4.6-1 Loading Gauge and Structure Gauge for HSR

## (2) Loading gauge and Structural gauge

### 1) Loading gauge

There are two typical loading gauge for HSR in the world, Shinkansen gauge and TSI gauge. TSI gauge is mainly used in Europe as the Technical Specification for Interoperability (TSI), and almost same gauge as Shinkansen is used in Japan, Taiwan and China.

TSI gauge is constrained by structures of conventional lines because HS Trains in Europe operate on conventional lines in some part. Meanwhile, Shinkansen gauge is formulated optimally independent from conventional line. Shinkansen gauge is widest in the world proven for HSR.

Fig. 4.6-2 shows a comparison of loading gauge between TSI and Shinkansen gauge. Shinkansen gauge is 250 mm wider than that of TSI, and roof shape is not squeezed and platform in Europe are lower and closed to rail-center, so body-shape is squeezed in the lower side and steps installed on body are required for transition. Contrastingly Shinkansen platform can be constructed at almost same height with floor level of rolling stock.

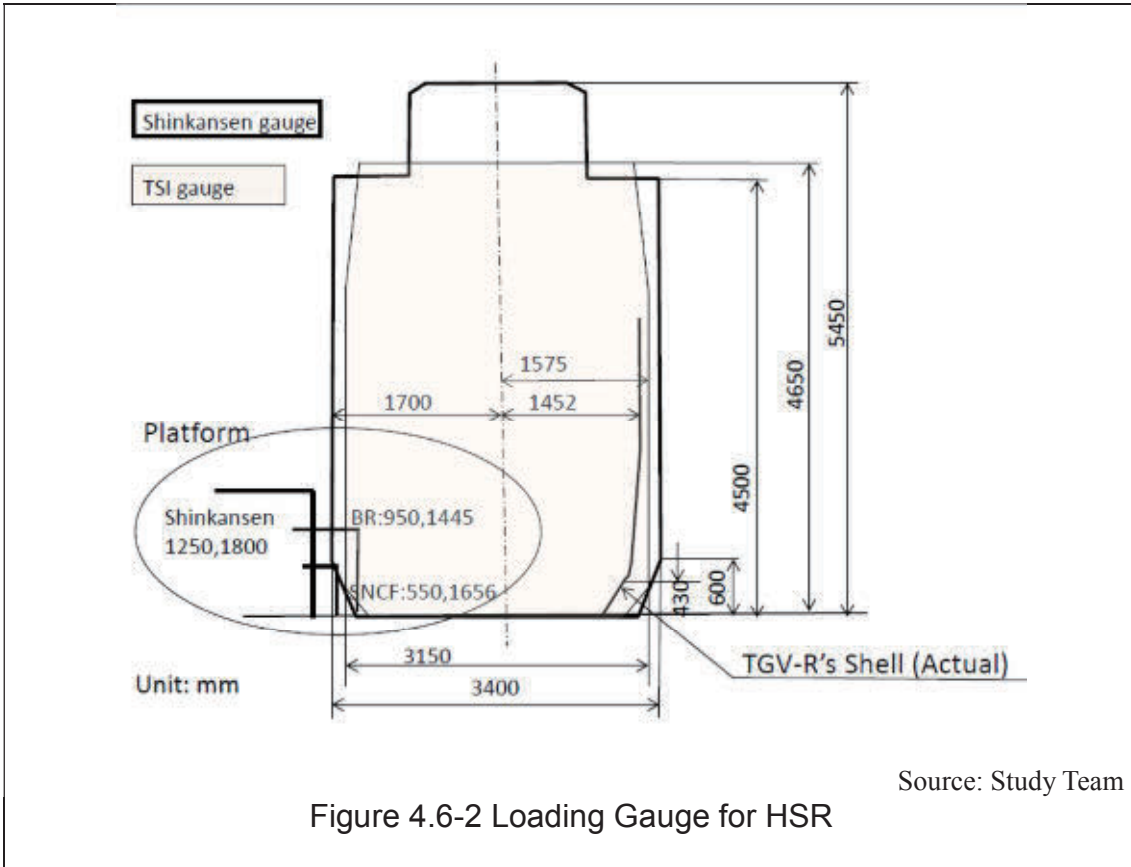

Figure 4.6-2 Loading Gauge for HSR

Fig. 4.6-3 shows a body cross-sectional comparison between Shinkansen and TGV. Shinkansen's body is over 400 mm wider than that of TGV. Therefore adopting Shinkansen gauge can install 5/6 seats arrangement in a row and have possibility to adopt double decker type easy and comfortably.

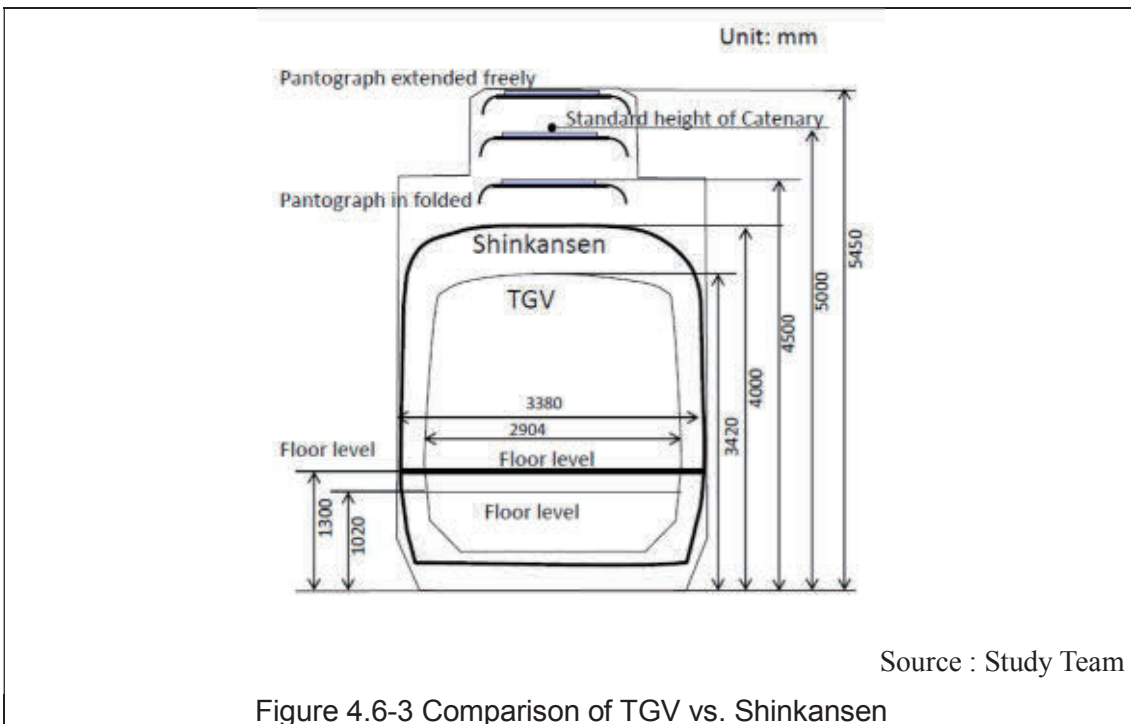

Figure 4.6-3 Comparison of TGV vs. Shinkansen

Conceptual breakdown of design dimension in vertical direction is also shown in Fig. 4.6-3. Cabin height, which affects interior comfort for passengers, reaches 2100 mm and actual roof height is about 3850 mm. Pantograph can be folded within the height of 4500 mm. Standard height of catenary is planned to be 5000 mm, considering insulating distance.

## 2) Loading gauge and Structural gauge

Formation of Loading gauge and Structural gauge, which is shown in Fig.4.6-4, is the most basic dimension because safety train operation without infringement can be secured through it. Shinkansen gauge is not a kinematic gauge but static gauge, therefore clearance between loading gauge and structural gauge should be left in mode that rolling stock is moving. In the upper side of platform level, it is easy to understand that it is enough because it is 500 mm. The most crucial part is distance between platform coping and body side of rolling stock. For the purpose of being safe as well as making passenger get on/ off easy, the dimension is selected in Japan. The recommendation is supposed to be 85 mm to platform where all trains stop and 125 mm to platforms some of trains pass through. This value has been proven for safety empirically for over 50-years operation and it has been recognized to be less than by measurement of the actual clearances through actual train operation. To make sure the fact, some detail explanation is following in the next section.

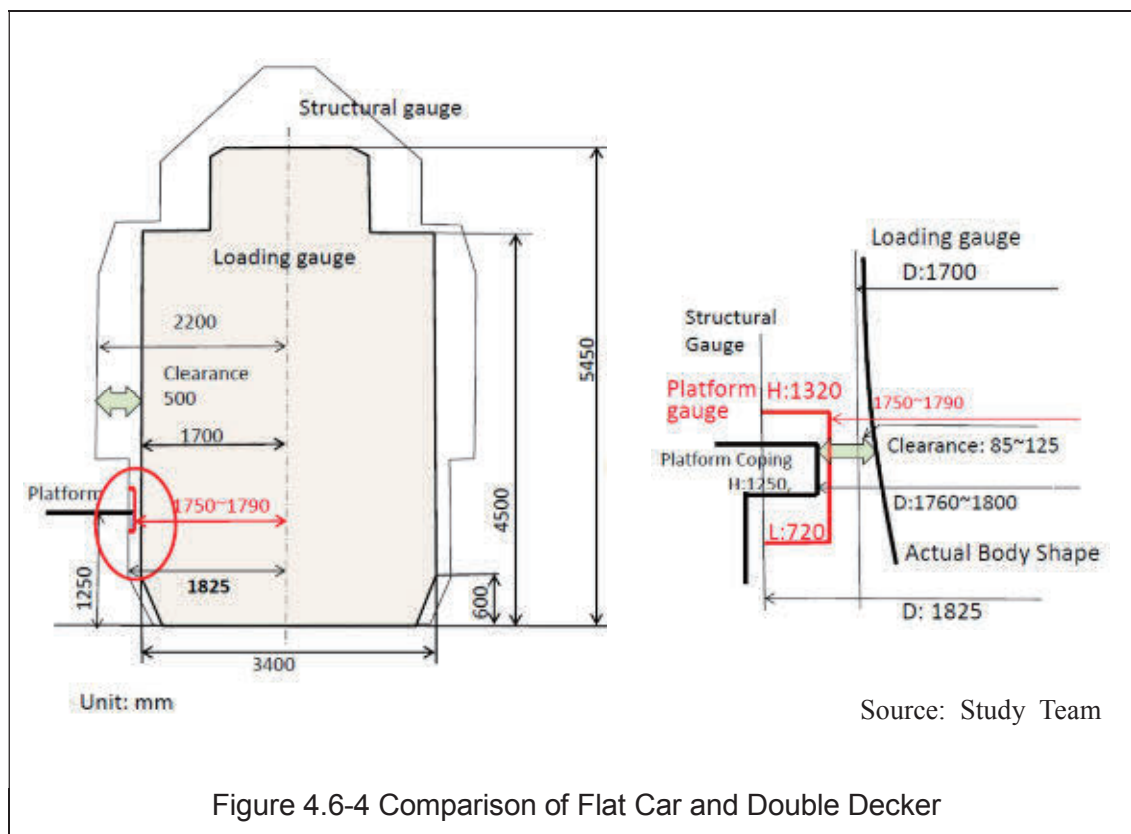

Figure 4.6-4 Comparison of Flat Car and Double Decker

### (3) Moving Dimension

Japanese Shinkansen rolling stock gauge, framed as rolling stock cross section is set by MLIT as the technical standard. In Japan, we use the static gauge for rolling stock gauge. The rolling stock must be inside of this frame, stopping on the straight and horizontal line. When the rolling stock begin to run, the body sways and sometimes goes out of this frame, but rolling stock never bump against structure built beside the rail. The reason why rolling stock never bumps is that there is margin between rolling stock gauge and structure gauge, and extent of rolling stock lateral sway is smaller than this margin.

Indian railway has also rolling stock loading gauge, but their gauge is kinematic gauge. Their consideration about loading gauge is different from our Japanese consideration. Japanese rolling stock gauge is static and adopted only stopping condition on straight rail, but Indian loading gauge is kinematic and rolling stock should not deviate from this gauge on moving condition and also stopping.

#### 1) Margin between Rolling Stock Gauge and Structure Gauge

Main values considered to be related to rolling stock deviation are as follows.

- ① The extent of wheel sway
- ② The extent of car body sway against the wheel set
- ③ The extent of car-end deviation due to yawing (Figure 4.6-5)
- ④ The extent of lateral car body shoulder deviation due to car body leaning when rolling occurs (Figure 4.6-5)
- ⑤ Increased deviation due to track tolerance.

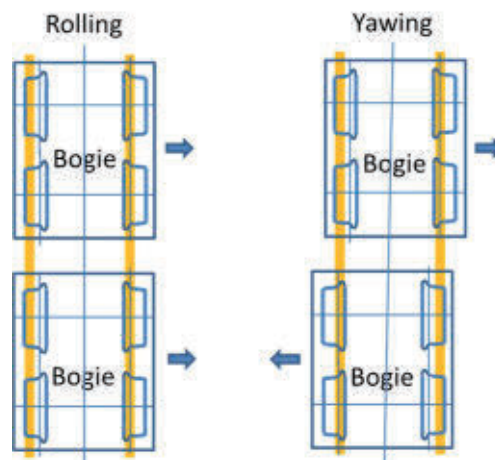

Source: Compiled by Study Team

Figure4.6-5 Difference between Rolling and Yawing

#### 2) Platform Clearance

The gap between the end edge of platforms and rolling stocks should be made as small as possible within the scope allowable for rolling stock movement.

Considering the safety of passenger, getting on and off Shinkansen, the narrow gap between rolling stock and platform is desirable.

##### ① Relation between Rolling stock floor height and platform height

Shinkansen rolling stock floor height from rail level is 1300 mm. It is desirable that rolling stock floor height and platform height are the same. If the difference of those heights can't be avoided, the floor height of rolling stock should be higher than that of platform, preventing from

passenger stumbling. Considering the drop of floor level by worn wheel or/and worn rail, it is determined that the height of platform is 1250mm from rail level.

② Distance from the End Edge of a Platform to the Track Center on a Straight Line

Rolling stock vibration passing through a platform will be bigger than that of running in and stopping at platform. Additionally, in consideration of track irregularity and other conditions, the values shown below are adopted for the distance between the end edge of a platform and the center of a track on straight line. (Based on the Tokaido Shinkansen Construction standard)

Distance between the end edge of a platform and the center of a track on straight line.

1,800mm: For platforms where trains pass without stopping

1,760mm: For platforms where all trains stop

③ For platforms where trains pass without stopping

In this study detailed below, a value of

$3,400/2 = 1,700\text{mm}$  was adopted as the rolling stock width.

a) Extent of rolling stock sway

Assuming that rolling stock lateral acceleration follows a Sine Wave, the amplitude of deviation due to rolling stock horizontal vibration can be expressed using Equation.

$$d = 1,000 \times a / (2\pi f)^2$$

Where

d: amplitude of deviation due to horizontal vibration (mm)

a: amplitude of lateral acceleration ( $\text{m/s}^2$ ) at half amplitude

f: frequency(Hz)

From the viewpoint of running safety, lateral acceleration defined as  $4.0\text{m/s}^2$ , in total amplitude as criteria, and the maximum measured actual value is similar.

If half amplitude is  $2.0\text{m/s}^2$  at a frequency of 1.2Hz, the amplitude of deviation due to horizontal vibration is calculated as follows :

$$d = 1,000 \times 2 / (2\pi \times 1.2)^2 = 35\text{mm}$$

The horizontal displacement of a rolling stock, calculated from the lateral acceleration, measured on the floor at the bogie center during running at 270km/h on the Joetsu Shinkansen Line was about 30mm, while the total amplitude of the lateral acceleration was  $3.0\text{m/s}^2$ .

Accordingly, the values obtained from the above estimation can be considered reasonable.

In case which two bogies rigged same car have opposite phase, if a wheel set shifts laterally by 10mm(maximum shift is 14mm, but probability of maximum shift is very low), lateral motion at the end of the car is calculated as:

$$(35+10) \times 24.5/17.5 = 63\text{mm}$$

b) Gauge tolerance

Gauge tolerance on Shinkansen lines should be 6mm or less for increment and 4mm or less for decrement. Assuming that a rolling stock move over a distance of  $\pm 3\text{mm}$  at the locations of two bogies rigged one car, lateral motion at the end of car is calculated as:

$$3 \times (24.5/17.5) = 4.2 \approx 4\text{mm} \quad (\text{for yawing})$$



c) Cross level tolerance

Cross level tolerance should be 7mm or less (Figure 4.6-6). Lateral deviation of rolling stock at floor height is calculated as follows (Figure 4.6-7):

$$7 \times 1300 / 1435 = 6.3 \approx 7 \text{mm}$$

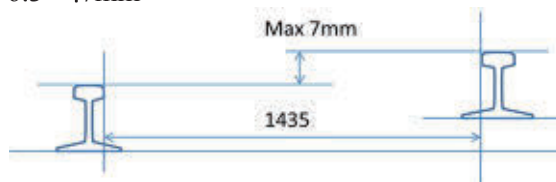

Source: Compiled by Study Team

Figure 4.6-6 Cross Level Tolerance

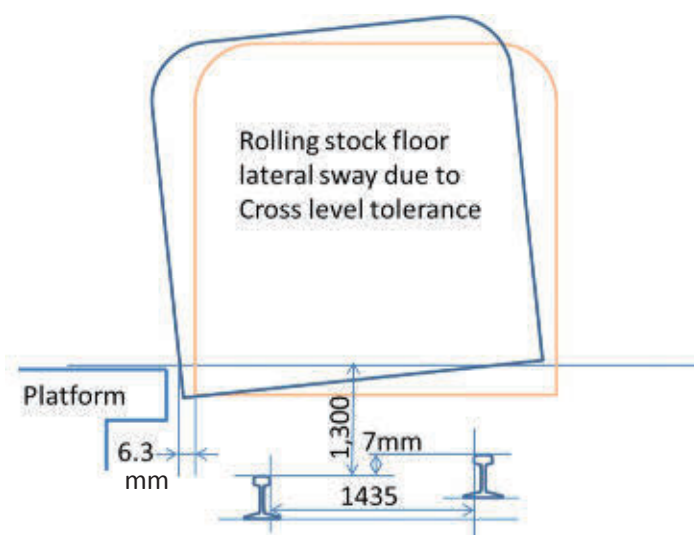

Source: Compiled by Study Team

Figure 4.6-7 Rolling Stock Floor Lateral Sway

d) Margin

The value should be 10mm.

Total distance from track center to the platform edge, where trains pass without stopping is calculated as follows:

$$= 1,700 + a) + b) + c) + d) = 1,700 + 63 + 4 + 7 + 10 = 1,784 \text{mm}$$

④ For platform where no trains pass without stopping

Rolling stock width: 3400mm

a) Extent of car body sway: 30mm

The extent of car body sway is specified as a total of 60mm, getting the sum of the 50mm extent of lateral car movement due to rolling and the 10mm extent of the lateral wheel set movement.

However, the measurement of the rolling stock-platform distance at Ueno Station on the Tohoku Shinkansen Line showed that the extent was 20mm or less.

Accordingly, the extent of car body sway is set at 30mm, including margin.

b) Gauge tolerance:  
3mm (for rolling)

c) Cross level tolerance:  
 $7 \times 1300 / 1435 = 6.3 \approx 7\text{mm}$

d) Margin: 10mm

Distance from platforms where train stop, the value is the total of the figures below:  
 $1,700 + a) + b) + c) + d) = 1,700 + 30 + 3 + 7 + 10 = 1,750$

The distances between the edge of platform and the track center where trains pass without stopping and all the train stops are summarized as Table 4.6-7.

**Table 4.6-7 Necessary Distance from the End Edge of a Platform to the Track Center**

Condition	Half car width (mm)	Extent of car-end movement (mm)	Gauge tolerance		Margin (mm)	Distance (mm)
			Gauge (mm)	Level (mm)		
Platform where trains pass without stopping	1,700	63	4	7	10	1,784
Platform where no trains pass without stopping	1,700	30	3	7	10	1,750

Source: Technical Regulatory Standards on Japanese Railways (Civil Engineering)

**3) Measurement of distance between a platform and a vehicle running at low speed**

Using an invisible laser sensor, the distance between a passing train and a platform was measured in 2002 at Ueno station (Figure 4.6-8). The result of the measurement using Shinkansen rolling stock shows an average change of 15mm or less, and even the maximum extent was 18mm or less for a train passing a platform at low speed and stopping at a platform (Table 4.6-8).

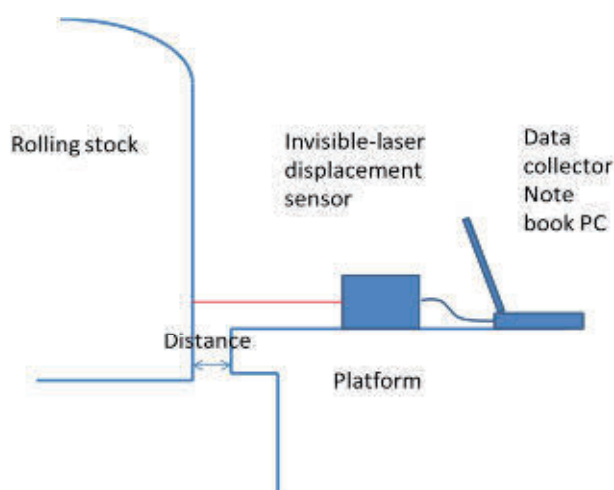

Source: Technical Regulatory Standards on Japanese Railways (Civil Engineering)

**Figure 4.6-8 Measurement Method**

Table 4.6-8 Measurement Result of Distance between a Platform and a Vehicle

No.	Type (cars/train)	Average value				Maximum	Account
		Rolling stock-platform distance (mm)		Change (mm)	Transit velocity (km/h)	Variation (mm)	
		Minimum	Maximum				
1	E1 (12cars)	75.4	90.0	14.6	24.2	17.9	Running in and Stopping
2	E1 (12cars)	79.2	91.4	12.2	61.2	17.5	Passing
3	E4 (8caes)	79.8	91.4	11.7	33.0	16.2	Running in and Stopping
4	E4 (8cars)	79.9	91.1	11.2	67.2	15.9	Passing

Source: Technical Regulatory Standards on Japanese Railways (Civil Engineering)

#### 4) Example of Calculation for passenger cars

When Shinkansen railways were first built, consideration described below were studied in relation to the margin for the gap between the width of the rolling stock gauge and structure gauge. As such studies were conducted before rolling stock sizes were specified, the result may not correspond to actual-size value.

##### a) Extent of wheel set sway: $y_1$

The margin of movement between wheels and rails is  $y_1$ .

It is expressed as  $y_1 = 14\text{mm}$

The distance from center of the wheel set to outside of the flange is 704~714mm. (Technical Regulatory Standard on Japanese Shinkansen)

$$\text{Gauge } 1,435/2=717.5 \quad 717.5 - 704 = 13.5 \approx 14.0\text{mm}$$

##### b) Extent of car body sway against the wheel set : $y_2$

$$y_2 = C_Y \cdot W_B \cdot \alpha_H$$

Where

$C_Y$  : lateral-direction spring constant of a bogie spring device against traverse force (m/kg)

$W_B$ : car body weight  $\times \frac{1}{2}$  (kg)

$\alpha_H$ : dimensionless number for lateral acceleration expressed using "g"

$$C_Y \cdot W_B \approx 0.5$$

Assuming that

$$\alpha_H = 0.1 \quad \text{for rolling}$$

$$\alpha_H = 0.15 \quad \text{for yawing}$$

For rolling  $y_{2R} = 0.05\text{m} = 50\text{mm}$   
 For yawing  $y_{2Y} = 0.075\text{m} = 75\text{mm}$

As these values are actually 50 to 60mm,  
 $y_{2Y} = 60\text{mm}$  is adopted based on the results of a running test using actual rolling stock.

c) Extent of car body deviation due to yawing (Figure 4.6-9) :  $y_{2Y'}$

$$y_{2Y'} = \frac{L}{l}(y_1 + y_{2Y}) = \frac{25}{19}(14 + 60) = 97\text{mm}$$

(suppose  $y_{2Y} = 75\text{mm}$ , then  $y_{2Y'} = 117\text{mm}$ )

Where

L: overall car body length. 25m

l: distance between two bogies centers. 19m

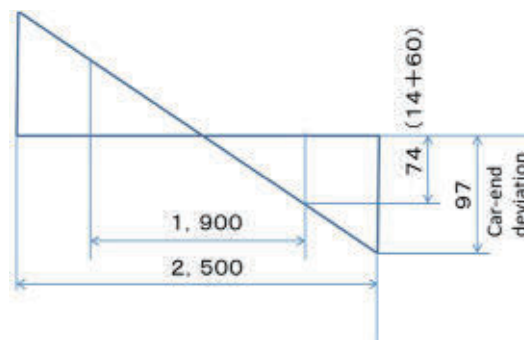

Source: Compiled by Study Team

Figure 4.6-9 Car End Deviation due to Yawing

d) Extent of lateral car body shoulder deviation due to rolling:  $y_R$

Using  $\varphi$  as the angle of car body inclination due to rolling

$$\varphi = C_\varphi \cdot W_B \cdot \alpha H$$

Where

$\varphi$ : car body inclination

$C_\varphi$ : moment spring constant of a bogie spring device against moment force (Radian/kg)

$W_B$ : car body weight  $\times \frac{1}{2}$  (kg)

$\alpha_H$ : dimensionless number for lateral acceleration expressed using “g”

The maximum lateral car body shoulder deviation due to rolling is as follows (Figure 4.6-10):

Height of car body center of gravity including springs = 1,800mm

Height of car body shoulder = 4,100mm

assuming  $C_\varphi \cdot W_B = 0.1$  and  $\alpha_H = 0.1$

then  $\varphi = 0.01$  radians

$$y_R = (4,100 - 1,800)\sin \varphi \approx 23\text{mm}$$

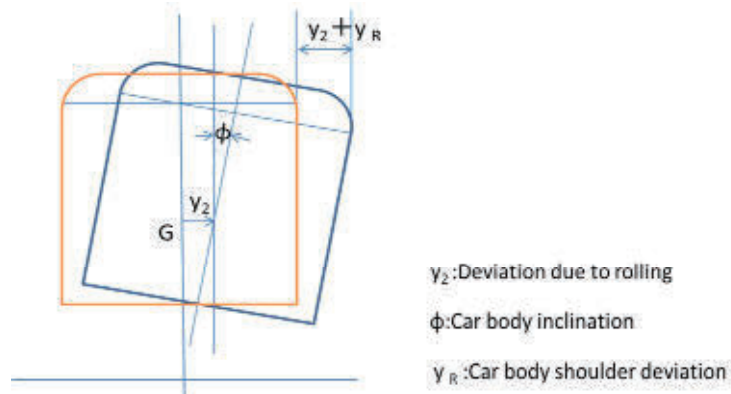

Source: Compiled by Study Team

Figure4.6-10 Total Deviation due to Rolling

e) Increased deviation due to track tolerances:  $v$

- Increased deviation due to gauge tolerance:  $v_e$

The gauge tolerance is 6mm, and increased deviation due to this tolerance is as follows:

$$\begin{aligned} \text{For rolling, } v_{eR} &= 3\text{mm} \\ \text{For yawing, } v_{eY} &= 4\text{mm} \end{aligned}$$

- Increased deviation due to cross level tolerance:  $v_s$

Taking an allowable inclination angle, the extent of car body shoulder deviation increase is as follows

$$\begin{aligned} v_s &= 22\text{mm} \quad (\text{cross level tolerance is } 7\text{mm}) \\ 7/1435 \times 4500 &\cong 22 \end{aligned}$$

- Temporary travel distance against structure gauge of track center:  $v_t$

$$v_t = 20\text{mm}$$

f) Calculation result

These deviation values can be expected in above cases.

However, when yawing reaches its maximum extent, rolling becomes small (in high speed running) in actual running. Similarly, when rolling reaches its maximum extent, yawing becomes small (in low speed running). Thus, assuming that problems relating to these phenomena occurring simultaneously will not arise, total extent of deviation can be determined as follows:

$$\begin{aligned} \text{For rolling} \\ D_R &= y_1 + y_{2R} + y_R + v_{eR} + v_s + v_t \\ &= 14 + 50 + 23 + 3 + 22 + 20 = 132\text{mm} \end{aligned}$$

$$\begin{aligned} \text{For yawing} \\ D_Y &= y_{2Y} + v_{eY} + v_s + v_t \\ &= 97 + 4 + 22 + 20 = 143\text{mm} \end{aligned}$$

With the above calculations, a margin of 300mm or more is secured against a 500mm gap between the rolling stock gauge and the structure gauge.

Accordingly, safety is assured for crews putting their head out of the window to check the side of their rolling stock.

Reference: Technical Regulatory Standards on Japanese Railways (Civil Engineering)

(4) Track Spacing

1) Distance between Track Centers

4.5m is proposed for the distance between track centers of Mumbai-Ahmedabad HSR from the aspects of technology and economy considering design speed of 350 km/h (Table 4.6-9). Distance between track centers is determined by the width of rolling stocks gauge and distance between two rolling stock gauges (Figure4.6-11).

Table 4.6-9 Comparison of Distance between Track Centers

	India (Mumbai-Ahmedabad)	Japan	Taiwan	China	Europe (TSI*)
Design Speed	350 km/h	260 km/h	350 km/h	350 km/h	300km/h < V
Operating Speed	320 km/h	320 km/h	300 km/h	300 km/h	300km/h < V
Rolling Stocks Gauge Width	3.4m	3.4m	3.4m	3.4m	3.15m
Minimum Distance between Track Center	4.5m	4.3m	4.5m	5.0m	4.5m

\*TSI (Technical Specifications for Interoperability)

Source: Study Team

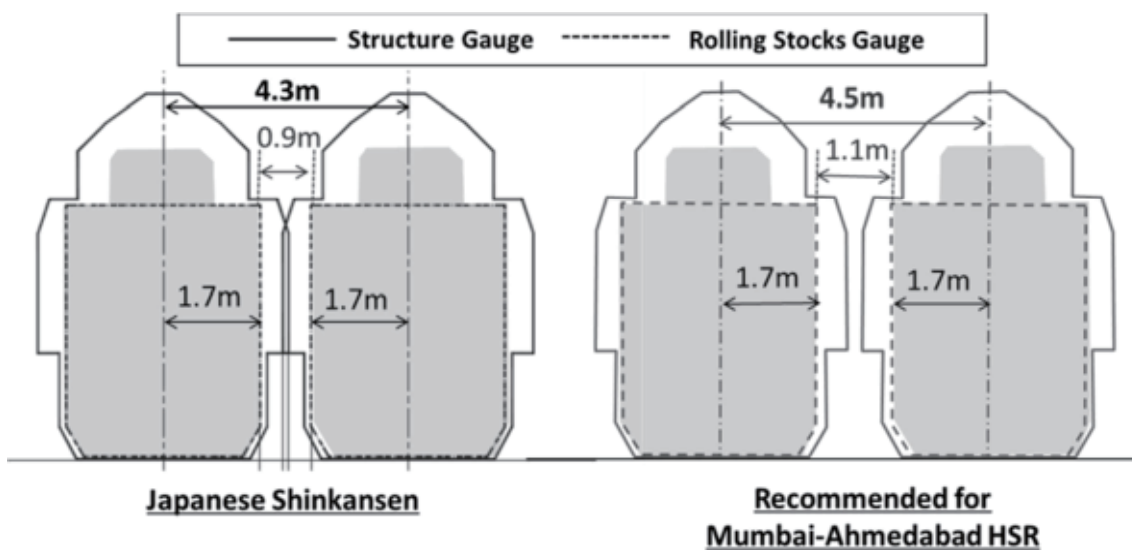

Source: Study Team

Figure 4.6-11 Comparison of Distance between Track Centers





Distance between two rolling stocks gauge in Japan was 0.8m at first Tokaido Shinkansen was constructed in 1964. The test on the actual service line of Tokaido Shinkansen was conducted at a relative speed of 571km/h using actual trains, and it was confirmed that there was no problem regarding the running safety. The result of maximum external pressure when trains cross each other  $120\text{kg/m}^2 = 1.2\text{N/m}^2$ . Later, the distance between two rolling stock gauges was changed to 0.9m for the reason of maintenance machines after Sanyo Shinkansen which started operation in 1972.



In a section where the train runs at a speed of 160km/h or slower, it was decided to allow narrowing the track spacing to the width of the maximum width of the basic envelop of the rolling stock gauge plus 0.6m (that means 4.0m of the distance between track centers) because the train draft is weak.

Although the design speed of Japanese Shinkansen is 260km/h, series E5 Shinkansen trains are now operating at a maximum speed of 320 km/h by improving the nose length and cross section for limiting wind pressure less than the one of 260 km/h operation (Table 4.6-10). Though 0.9m distance of two rolling stocks is theoretically allowed for the speed of 350 km/h, we recommend 1.1m for keeping the space for the future. Taiwan HSR is also adopting the distance between two rolling stocks as 1.1m which design speed is 350 km/h.

**Table 4.6-10 Improvement of Rolling Stock and the Operating Speed  
with the 4.3m Distance of Tracks**

Types of Train	Shape of Head car	Length of Nose	Cross Section	Distance of Track Centers	Maximum Operating Speed
Series 0		3.9m	12.2 m <sup>2</sup>	D=4.2m	220 km/h
Series 200		3.9m	12.2 m <sup>2</sup>	D=4.3m	275 km/h
Series E2		9.1m	11.2 m <sup>2</sup>	D=4.3m	275 km/h
Series E5		15.0m	10.8 m <sup>2</sup>	D=4.3m	320km/h

Source: Study Team

## 2) Width of Formation Level

Width of formation level should satisfy the function of maintenance work and facility placement such as cables and electrical poles. Minimum width of formation level is determined by width of rolling stocks, distance between tracks, safety distance of draft, and walkways. Study team proposes the width of formation level as 11.5m totally (Figure4.6-12, Table4.6-11). Safety distance of draft should be 0.8m or more. It was decided by experiment and calculation in Japan to keep the wind speed 17m/s or less for workers to take refuge safely (Figure4.6-13). 1.0m walkways are on both side for the purpose of evacuation and maintenance.

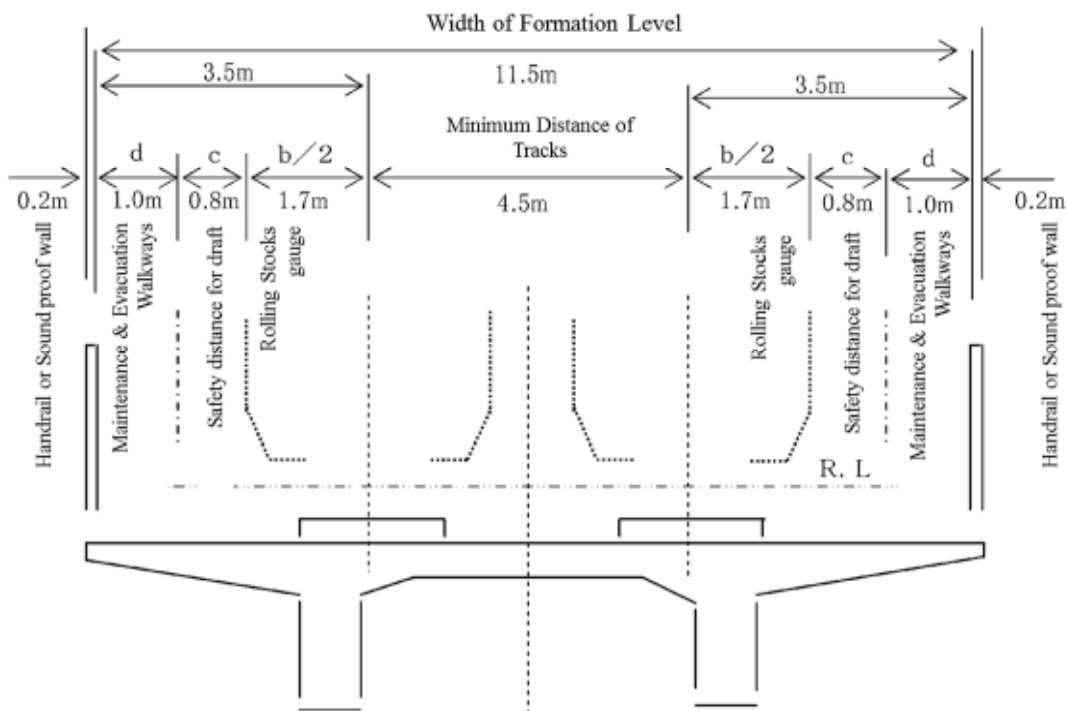

Source: Study Team

- a. Distance between track centers: 4.5 m
- b. Rolling stock gauge:  $1.70 \text{ m} \times 2 = 3.4 \text{ m}$
- c. Safety distance for draft:  $0.8 \text{ m} \times 2 = 1.6 \text{ m}$
- d. Maintenance and Evacuation walkways:  $1.0 \text{ m} + 1.0 \text{ m} = 2.0 \text{ m}$

$$\text{Total (width of formation level)} = \underline{11.5 \text{ m}}$$

(Excluding Handrails or Sound proof walls)

Figure 4.6-12 Width of Line Section

Table4.6-11 Comparison Table of Width of Formation Level

Dimensions		Recommendation for India	Japan*
a.	Track Spacing	4.5m	4.3m
b.	Rolling Stock Gauge	3.4m	3.4m
c.	Safety distance for draft	0.8m + 0.8m	0.8m + 0.8m
d.	Walkways	1.0m + 1.0m	1.0m + 0.5m
Total*		11.5 m	10.8 m

\* Technical Regulatory Standards on Japanese Railways (Civil Engineering)

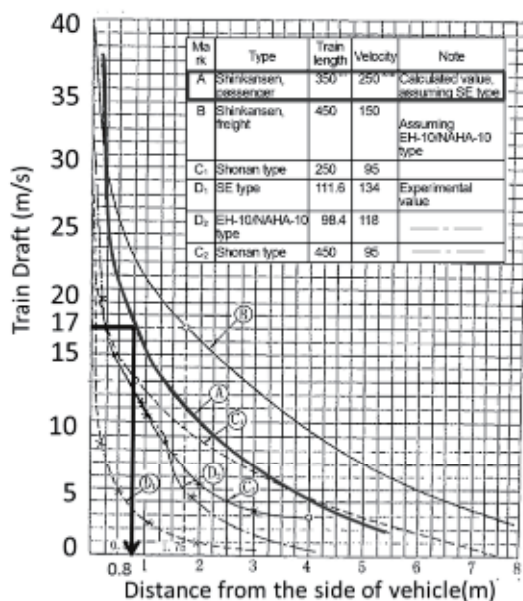

Source: Technical Regulatory Standards on Japanese Railways (Civil Engineers)

Figure 4.6-13 Train Draft and Distance from the Side of Vehicle

(5) Curves

1) Cant

The cant is the maximum difference in height between outer and inner rails, measured at the center of the rail head surface (in mm).

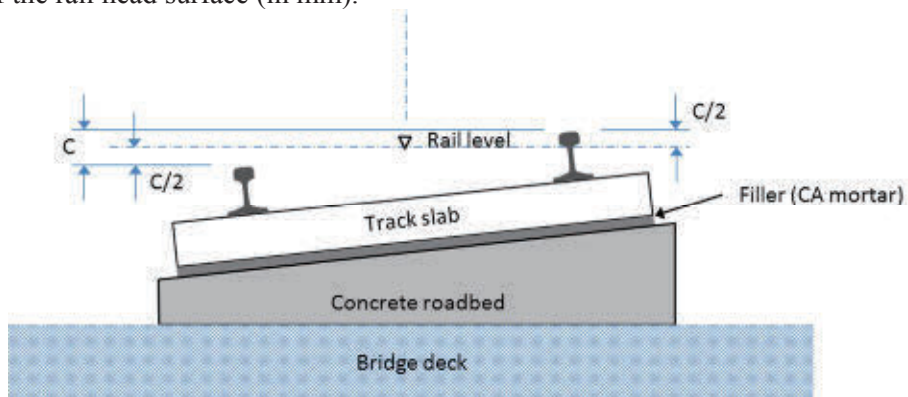

Figure 4.6-14 An Example of Cant Providing in Slab-track

①Equilibrium cant  $C_{eq}$

The equilibrium cant (balancing cant) required on a 1435 mm gauge can be calculated using the formula:

$$C_{eq} = 11.8 V^2 / R$$

Where,

V: Train speed through the curve (km / h)

R: Radius of the curve (m)

② Allowable cant  $C_a$  (Maximum cant)

When cant is provided, it is necessary to set its upper limit in consideration of reduction of ride comfort due to vehicle-body inclination and the risk of wind-related overturning toward the inside of the curve.

Study team proposes 180 mm for allowable cant based on above verifications.

③ Applied cant  $C_m$

Applied cant shall be set to provide the best practical ride quality to the majority of the passengers on the trains passing over the particular curve without violating criteria limits.

④ Cant deficiency  $C_d$

The cant deficiency is the difference between the applied cant on the track and the equilibrium cant for the vehicle at the particular stated speed.

The cant deficiency limit (Maximum cant deficiency) shall be determined considering the following factors:

- Whether or not to overturn toward the outside due to crosswinds blowing from the inside of curve.
- Whether the excess centrifugal force impairs ride comfort or not.

Study team proposes 90 mm for Maximum cant based on above verifications.

2) Minimum Curve Radius for 350 km/h

Unless otherwise specified, the minimum radius of curvature to be used in the design of the alignment shall be 6,000 m.

Curve radius is determined according to the cant limits given in clause 1). The equation for relationship between curve radius, train speed and cant limits is as follow:

$$R = G V^2 / g (C_m + C_d)$$

Where,

R: Curve radius (m)

G: Gauge or distance between wheels supports (m)

V: Train speed (m / s)

g: Acceleration of gravity (9.8 m / sec<sup>2</sup>)

$C_m$ : Applied cant (m)  $\leq$  Allowable cant  $C_a = 180$  mm

$C_d$ : Cant deficiency (m)  $\leq$  Maximum 90 mm

The calculation of a curvature radius to secure curve speeds equivalent to 100 % of the maximum design speed based on above equation results in the values shown in Table 4.6-12 and Figure 4.6-15.

Table 4.6-12 Curve Radius Corresponding to the Maximum Design Speed

Maximum design speed	Curve radius	Calculation conditions
350 km/h	5,358 m	$G = 1,500$ mm $C_m = 180$ mm $C_d = 90$ mm
300 km/h	3,937 m	
270 km/h	3,189 m	
240 km/h	2,520 m	
220 km/h	2,117 m	
200 km/h	1,750 m	

Source: Technical Regulatory Standards on Japanese Railways (Civil Engineers)

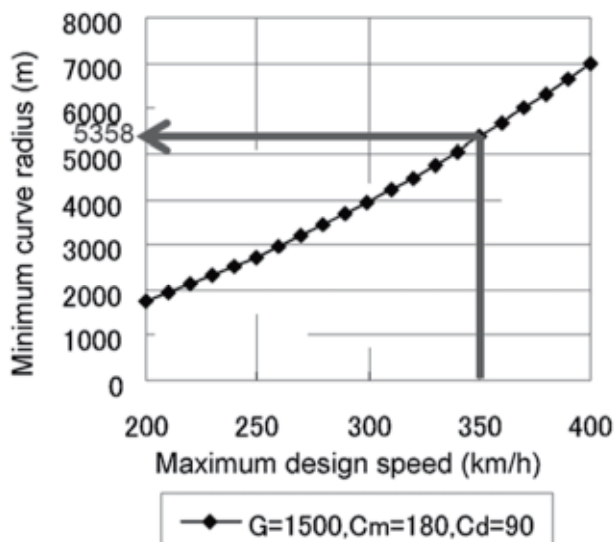

Source: Technical Regulatory Standards on Japanese Railways (Civil Engineers)

Figure 4.6-15 Maximum Design Speed and Curve Radius

### 3) Minimum Vertical Curve

Vertical radius shall be determined in response to the limits in consideration of ride comfort deterioration with greater vertical acceleration of the vehicle.

The steady vertical acceleration  $\alpha$  acting in the upward direction on a vehicle running at  $V$  m/sec in a section containing a vertical curve with a radius of  $R$  meters can be expressed by following equation:

$$\alpha = V^2 / (R g)$$

Where,  $g$ : acceleration of gravity ( $9.8 \text{ m / sec}^2$ )

In general, the value  $\alpha$  for acceptable comfort is limiting to  $0.04 g$ .

In case of following condition,

$\alpha$ :  $0.04 g$ ,  $V$ :  $350 \text{ km/h}$

Radius of vertical curve is obtained as follow:

$$R = 24,114 \text{ m.}$$

Study team proposes  $25,000 \text{ m}$  for minimum radius of vertical curve based on above verifications.

### 4) Gradients

The gradients shall be determined based on vehicle acceleration and brake performance.

Study team proposes the maximum gradients to be used in the design of the alignment as shown below:

- For main line: desirable 1 in 67 (15‰)
- For main line: maximum 1 in 40 (25‰)
- For depot connecting line: 1 in 33.3 (30‰)
- For station yard: 1 in 333.3 (3‰)

### 5) Transition Curve

#### ① Length

The length of transition curves shall be determined by using the maximum value of length calculated using a series of equations  $L1$ ,  $L2$ ,  $L3$  as shown in Table 4.6-13

Table 4.6-13 Series of Equations for Length of Transition Curve

Train speed	Equations	Where:
$V \geq 160$ km/h	$L1 = 1.0 C_m$ $L2 = 0.0097 C_m V$ $L3 = 0.0117 C_d V$	$C_m$ : Applied cant (mm) $C_d$ : Cant deficiency (mm) $V$ : Maximum speed
$V \leq 160$ km/h	$L1 = 0.8 C_m$ $L2 = 0.0062 C_m V$ $L3 = 0.0075 C_d V$	

The above equations consider each factor as shown below:

- L1: for safety against derailment caused by three-point support of vehicle.
- L2: for ride comfort against the temporal rate of change in cant.
- L3: for ride comfort against the temporal rate of change in excess centrifugal force.

②Shape

Study team proposes Sine Half-Wavelength Diminishing Tangent Curve.

The three major shapes used for transition curves on railways are the cubic parabola, the clothoid curve and the half-sine wave. They are distinguished by the shapes along which curvature changes.

The curvature of a transition curve at the connection point with a tangent track is zero, and becomes  $1/R$  at the connection point with a circular curve. A cubic parabola and a clothoid curve are graphic forms for which a method involving a linear change in curvature between 0 and  $1/R$  (a linear regression) is adopted, and a half-sine wave is a graphic form for which a method involving curved change (for a curved transition curve) is adopted.

In comparison with a half-sine wave-shaped transition curve, a cubic parabola-shaped transition curve whose curvature and cant show linear regression exhibits discontinuity of curvature and cant at its start and end points (Figure 4.6-5). Such discontinuity may contribute to train vibration during high-speed running. Accordingly, half-sine wave transition curves shall be applied on High Speed Railways.

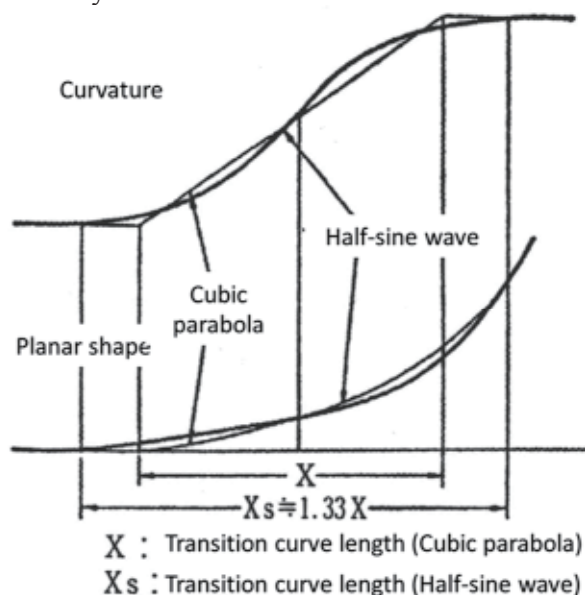

Source: Technical Regulatory Standards on Japanese Railways (Civil Engineers)

Figure 4.6-16 Comparison of Half-sine Wave Gradient with Linear Gradient



## 6) Turnouts

Turnouts shall comply with the necessities of train operations.

Speeds on through routes shall comply with the main line design speed regardless allowed speed on the diverging route.

Study team proposes the geometric concepts for the turnouts shown in Table 4.6-14.

**Table 4.6-14 Geometric Concepts for the Turnouts**

Factors	For Main Line	For depot
Number of turnouts	1 : 18	1 : 9
Structure of crossing	Movable nose	Fixed nose
Allowed speed on the diverging route	80 km/h	40 km/h
Crossing angle	3° 11'	6° 22'
Length of crossing	71.3 m	30.0 m

## (6) Axle Load

Study team adopts the axle load P-17. Study team proposes the axle load P-17 from the designing viewpoint in consideration of the axle loads of maintenance cars and to guarantee the durability of structures.

### 4.6.3 Track Structure

#### (1) Track structure

##### 1) Comparison between ballast and ballast-less tracks

When tracks are broadly classified from the viewpoint of their structure, there are two versions: one is the “ballast track” that has been used since the dawn of the railway era and the other the “ballast-less” track that is extensively adopted in recent years. In discussing the track structure for the high-speed railway in India, let’s compare and discuss these two categories of railway tracks.

In constructing the first high-speed railway, or the Tokaido Shinkansen railway opened in 1964, Japan adopted the ballast track well proven in those days. However, as track breakdown progressed faster than anticipated as a result of increases in the speed and frequency of train operation, an enormous amount of costs is required for track maintenance after inauguration.

To save the maintenance and upkeep costs, therefore, Japan promoted development of a “manpower-saving track structure” and introduced the ballast-less track (slab track) thus developed into the Tokaido Shinkansen railway. Study team will compare below the construction and maintenance costs required for ballast tracks and slab tracks of Shinkansen railways in Japan.

#### ① Construction cost

Table 4.6-15 summarizes the construction cost (per track length 1 m) to lay tracks on viaducts and earth structures (records at the construction of projected Shinkansen railways).

**Table 4.6-15 Comparison of Construction Costs between Tracks of different Structures**

Track type	Ballast track		Slab track	
	—	Installation of ballast screen	Plate-type track slab	Frame-type track slab
Materials cost	74	74	86	83
Construction cost	34	34	55	44
Others	14	54	14	14
Total	122	162	155	141
Ratio	1.0	1.33	1.27	1.16

Source: “New Permanent Ways” (ballast track, plate-type slab track)  
“Track Materials, New Edition” (ballast screen, frame-type slab track)



Figure 4.6-17 Plate-type Slab Track



Figure 4.6-18 Ballast Track  
(installed with ballast screens)

Table 4.6-13 indicates that the construction cost of ballast tracks is 20 to 30% higher than that of slab tracks. In I/R 1, Study team referred to the “necessity of measures to prevent ballast from

flying in high speed operation.” The construction cost of ballast tracks installed with ballast screens is higher than that of slab tracks.

② Maintenance cost

For the San-yo Shinkansen railway, Japan adopted ballast tracks in the sections inaugurated first and slab tracks in the sections extended later. To compare the maintenance costs for ballast and slab tracks, Figure 4.6-19 shows the maintenance costs for San-yo Shinkansen in different years.

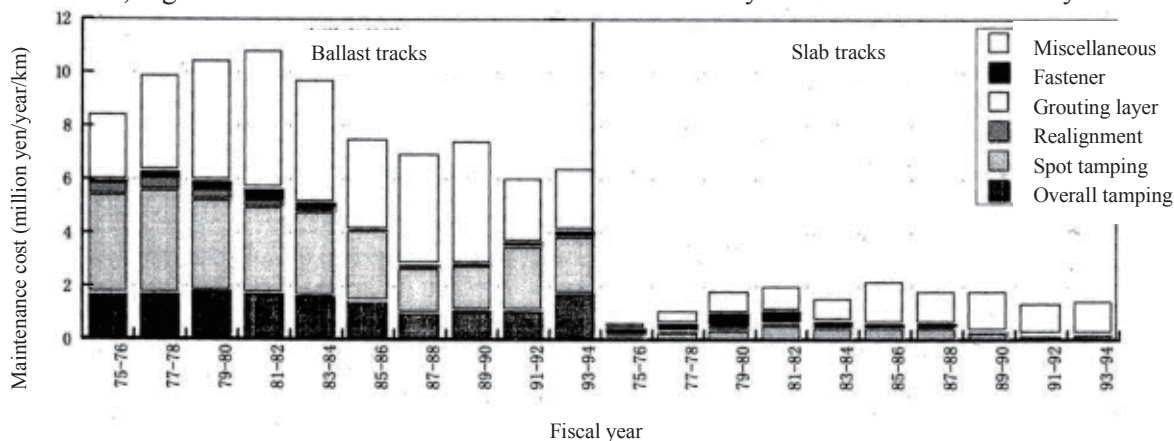

Source Railway structure designing standards and commentaries

Figure 4.6-19 Track Maintenance Costs in different Fiscal Years, San-yo Shinkansen

The track conditions of San-yo Shinkansen are all subject to evaluation for track maintenance purposes according to unified standards irrespective of their structures. As slab tracks don't require specific "ballast tamping," they feature comparatively small displacements to significantly reduce the workload of track maintenance such as "spot tamping." In concrete terms, the approximate maintenance cost is approximately 7.0 million yen/year/km for ballast tracks and 1.7 million yen/year/km for slab tracks, or the latter is approximately one-fourth the former every year.



Figure 4.6-20 Ballast Tracks of San-yo Shinkansen



Figure 4.6-21 Slab Tracks of San-yo Shinkansen

③ Comparison of life-cycle costs

Based on the construction/maintenance costs referred to in the above paragraphs (1) and (2), Study team calculated the life-cycle costs of ballast and slab tracks. For the results, see Table 4.6-16, which covers the total cost including working expenses (employee salary, repairing cost and fixed asset tax) in addition to the construction cost.

Table 4.6-16 Comparison of Calculated Life-Cycle Costs  
(per track length 1 m, unit: yen)

	Ballast track (A)	Slab track (B)	Difference (B-A)
Construction cost	122,200	155,000	32,800
Cost per year	14,636	9,213	-5,423
(Inclusive) Working expenses	(10,237)	(3,199)	(-7,038)
(Breakdown) Employee salary	[5,600]	[1,400]	[-4,200]
Repairing cost	[3,990]	[810]	[-3,180]
Fixed asset tax	[647]	[989]	[342]
(Inclusive) Capital cost	(4,399)	(6,014)	(1,615)
(Breakdown) Depreciation cost	[1,662]	[2,542]	[880]
Interest	[2,737]	[3,472]	[735]
Total cost per year excluding interest	11,899	5,741	-6,158
Additional investment recovery period	$32,800/6,158 = 5.33$ years		

Table 4.6-14 indicates that the additionally invested construction cost will be recovered in a period of a little over five years, if slab tracks were adopted, for the reason that expenses can be cut substantially with slab tracks, despite that the construction cost is approximately 30% higher than that required for ballast tracks.

Consequently, Study team believes that slab tracks (ballast-less tracks) desirably be adopted for the Indian high-speed railway.

2) Structure of Slab Track

Ballast less track structures have been developed and adopted in the world, of which the most typical ones from the viewpoint of the route length of their installation are the slab tracks in Japan developed as a forerunner and now used as the standard track of Shinkansen.



Figure 4.6-22 Frame-type Slab Track

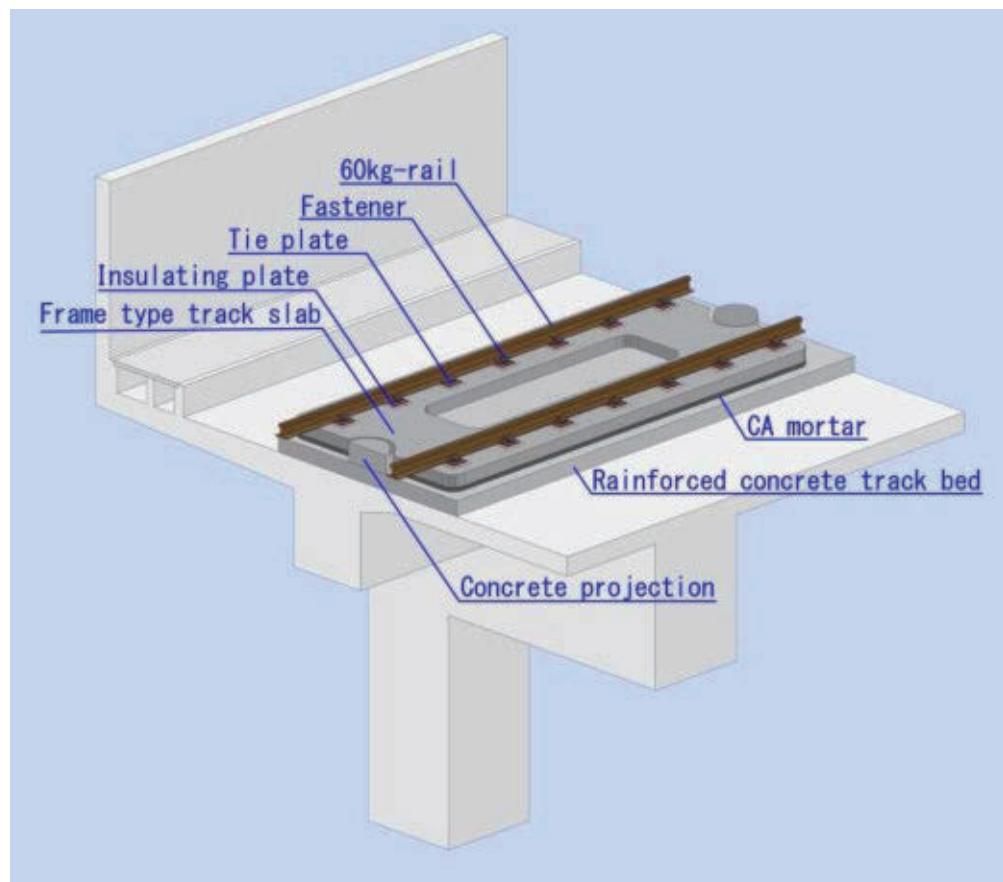

Figure 4.6-23 Structure of Slab Track



See Figure 4.6-24 for the standard cross-sections of slab tracks on different civil engineering structures..

- Viaduct and bridge sections.

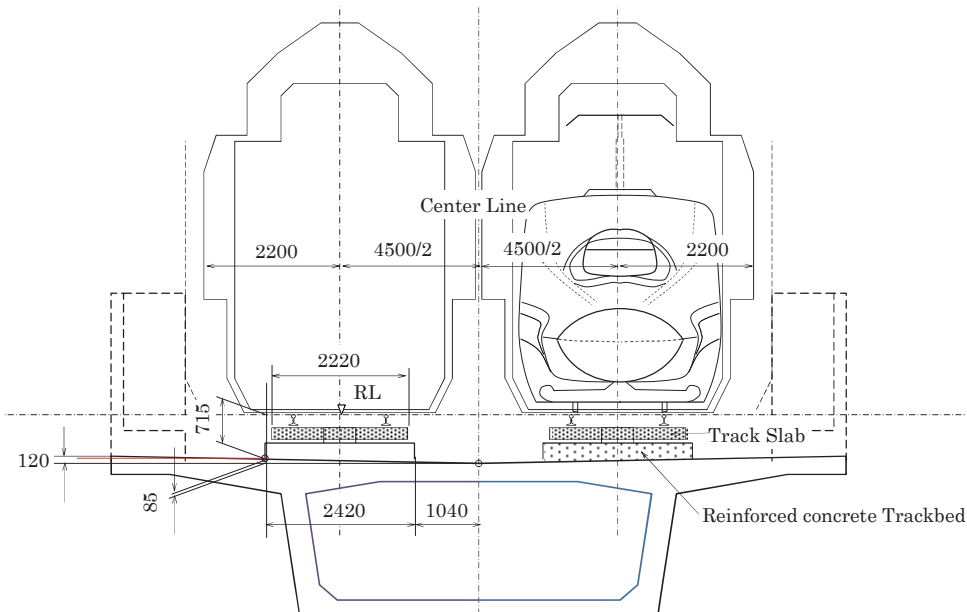

Figure 4.6-24 Slab Track Standard Cross-section (Viaduct and Bridge sections)

- Tunnel section

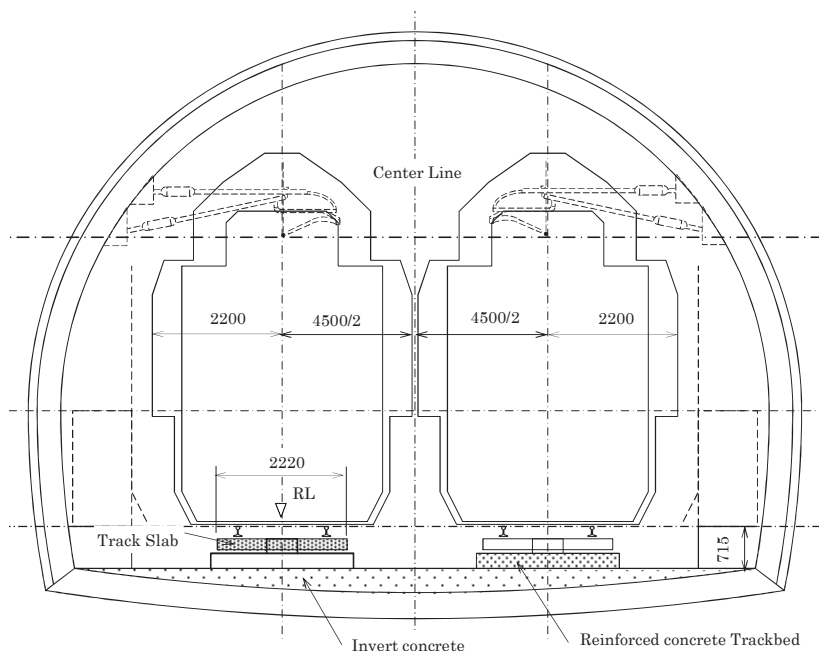

Figure 4.6-25 Slab Track Standard Cross-section (Tunnel sections)



- Embankment, cut and ground sections

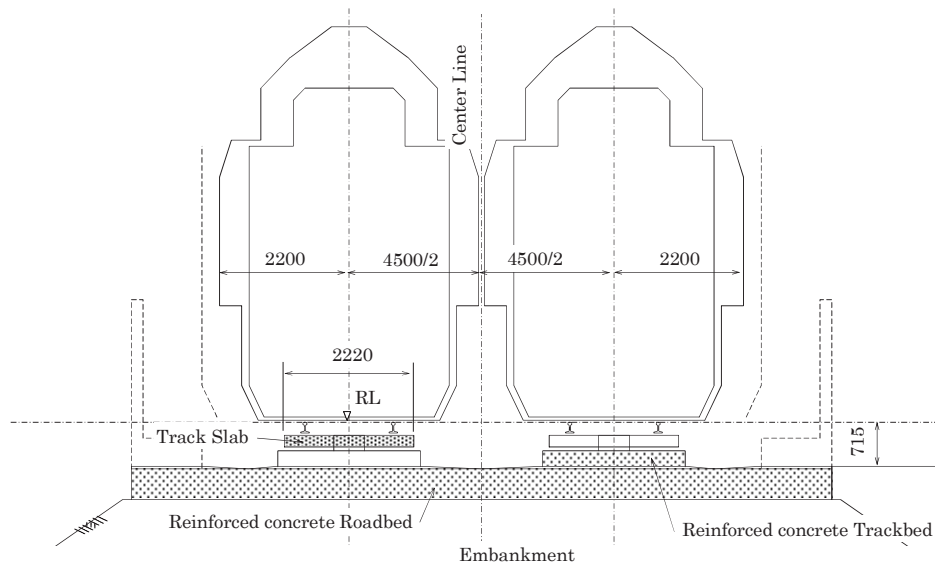

Figure 4.6-26 Slab Track Standard Cross-section (Embankment sections)

### 3) Recommendation

For slab tracks, the number of construction machines required for track construction work changes depending on the period of construction work, which subsequently changes the cost of construction work as well. Japan has steep topographical features with its railways studded with viaducts and tunnels of different types in different sections. Therefore, the environment for construction work is far from satisfactory with private houses swarming close to permanent ways to make it extremely difficult to guarantee working time and working yards around the construction site. In contrast, the Indian HSR line will run through large plains to guarantee satisfactory conditions for construction work to make the speed of slab track construction work higher than in Japan, which consequently makes the construction cost lower.

Based on the above discussions, Study team recommends India to adopt the slab track that is proven in Japan with respect to the stability for operation of high-speed trains, manpower saving features, construction cost and speed of execution.

#### 4.6.4 Electric Power Equipment

##### (1) Comparison/Analysis

###### 1) History of Electrification System for HSR

There are three typical electrification systems, Single 25 kV without BT's, Single 25 kv with BT's and AC 2x 25kV, that has been adopted for high-speed rails. Table 4.6-17 shows the history of feeding systems used for different high-speed rails in the world. The Tokaido Shinkansen (Tokyo to Shin-Osaka) in Japan is the world's first high speed rail, to achieve the speed of 200km/h in 1964. For this, the feeding system used was the single 25kV with Booster Transformer (BT's) system, because this system was well proven for conventional lines. However, it was found that in this system, the produced arc is very intense when the pantograph of the train passes through the air section near BT. As a counter measure, research on 2x25kV system was taken up from 1965. Sanyo Shinkansen line, which opened in 1972 from Shin-Osaka to Okayama, has adopted the 2x25kV system as the world's first commercial use of this system. Thereafter, all the Shinkansen lines in Japan, has been built using the 2x25kV system.

The single 25kV without BT system, could not be adopted in Japan because the houses are very close to the railway line and also the communication lines are very close. However, since such problems are less in the Paris South-East (PSE) line of France which opened in 1981, they have adopted the single 25kV without BT. In addition, the 2x25kV system it used in areas where incoming lines are insufficient. In addition, the Madrid to Barcelona line of Spain, which opened in 1992 adopted the single 25kV without BT system. This is due to the technical assistance of Germany. However, 2x25kV system has been adopted for the Madrid to Lieda line. In this way, the single 25kV with or without BT system has been used for the first high speed railways in the beginning. But the 2x25kV system has been adopted in most countries at present.

In addition, the Tokaido Shinkansen of Japan which was the single 25kV with BT's system became 2x25kV system in 1991. The Paris South-East line of France was also converted to 2x25kV.

The feeding system as used in recently developed high-speed rails is shown in table 4.6-18.

Table 4.6-17 History of Electrification System

Year	Country	Feeding System	Traction Substation (TSS) Spacing (Approximately)
1964	Japan (Tokaido)	1x25kV with BT's	20km
1972	Japan (Sannyo)	2x25kV	50km
1981	France (PSE)	1x25kV without BT's (Partly 2x25kV)	30km (1x25kV) 90km(2x25kV)
1989	France (Atlantique)	2x25kV	60km to 70km
1991	Japan (Tokaido)	Converted to 2x25kV	40km
2005	France (PSE)	Converted to 2x25kV (170km)	60km

**Table 4.6-18 Feeding systems adopted for recent High Speed Rails**

Year	Country	Feeding System
2011	Japan (Kyushu)	2x25kV
2007	Taiwan (HSR)	2x25kV
2004	South Korea (KTX)	2x25kV
2011	China (Beijing to Shanghai)	2x25kV
2007	France (LGV Est)	2x25kV
2006	U.K. (HS1)	2x25kV
2008	Spain (Madrid to Barcelona)	2x25kV
2009	Italy (Rome to Napoli)	2x25kV

## 2) Standards for the Electric Installations

The standards for the electric installations of the major sections in the subject countries where HSRs are in operation are listed in Table 4.6-19 and Table 4.6-20. All of the sections with AC feeding system of 50Hz/60Hz have a 2x25kV with Auto-Transformer (AT) feeding system as shown in the table.

**Table 4.6-19 Standards for electric installations of the major sections in the subject countries (Asian region)**

Name of country	Japan	Taiwan	South Korea	China
Section	Tokyo to Morioka	Taipei to Zuoying	Seoul to Busan	Beijing to Tianjin
Total length (km)	496	345	412	115
Feeding voltage (kV)	25	25	25	25
Frequency (Hz)	50	60	60	50
Feeding system	AT	AT	AT	AT
Over head equipment (OHE)	Compound catenary	Compound catenary	Simple Catenary	Simple catenary

THSR: Taiwan High Speed Rail

KTX: Korea Train eXpress

Feeding system (AT): 2x25kV with AT's

**Table 4.6-20 Standards for electric installations of the major sections in the subject countries (European region)**

Name of country	France	Germany	Spain	Italy
Section	Paris to Boudrecourt	Koln to Rhein/Main (Frankfurt/Wiesbaden)	Madrid to Lieda	Rome to Napoli
Total length (km)	301	197	447	205
Feeding voltage (kV)	25	15	25	25
Frequency (Hz)	50	16.7	50	50
Feeding system	AT	1x15kV	AT	AT
Over head equipment (OHE)	Simple catenary	Simple catenary with stitch wire	Simple catenary withstitch wire	Simple catenary

Feeding system (AT): 2x25kV with AT's

### 3) Feeding System

Feeding systems adopted for HSRs and their characteristics are listed in Table 4.6-19.

As shown in main characteristics in Table 4.6-21, a 2x25kV with AT feeding system can provide high-speed trains with high-power supply. And it also has a characteristic which the interval between substations is longer than that of the other systems.

**Table 4.6-21 Feeding systems adopted for HSRs and their characteristics**

Name	Circuit configuration	Main characteristics
Single 25kV without BT's		<ol style="list-style-type: none"> <li>1. OHE composition is simple.</li> <li>2. Induction voltage problem is bigger.</li> <li>3. OHE voltage drop is bigger.</li> <li>4. Rail potential is bigger.</li> <li>5. Shorter Sub-station spacing.</li> </ol>
Single 25kV with BT's		<ol style="list-style-type: none"> <li>1. Countermeasure for inductive problem.</li> <li>2. OHE voltage drop is bigger.</li> <li>3. Severe troubles with air-sections.</li> <li>4. Shorter Sub-station spacing.</li> </ol>
2x25kV with AT's		<ol style="list-style-type: none"> <li>1. Countermeasure for inductive problem.</li> <li>2. Suitable for heavy loads.</li> <li>3. Longer Sub-station spacing.</li> <li>4. OHE composition become complicated.</li> </ol>

E: Feeding voltage (25kV)    T: Catenary    R: Rails    RC: Return conductor  
 BT: Booster transformer    R: Resistor    AT: Auto-transformer  
 NF: Negative feeder (-25kV)    OHE: Over-head equipment

### (2) Recommendation

#### 1) Feeding System

A typical feeding system is shown in Figure 4.6-27. Since the interval between traction sub-station (TSS) is 50 to 60 km at HSRs of major countries, their average, 55 km, is used. A sectioning post (SP) is installed around the midpoint of it, and a sub sectioning (SSP) is installed between TSS and SP.

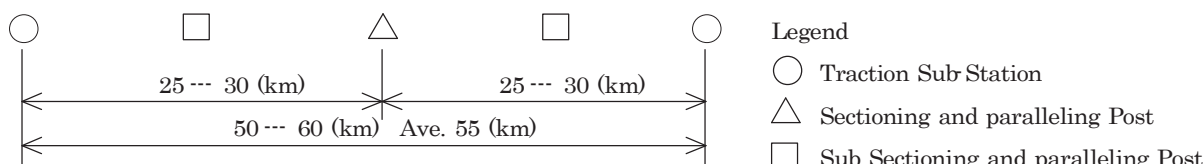

Figure 4.6-27 A typical feeding system

## 2) Plan for Power Incoming

The incoming lines to the TSS is taken from the bus bars of the grid substation of the power company as shown in Figure 4.6-28 or from a tapping of the transmission system as shown in Figure 4.6-29. Therefore, the share of expenses is composed of a) the construction cost of the extra-high voltage bus (EHV Bus) of the power company, b) the cost for renovation of the branch in the transmission system, and c) construction of the incoming lines from the grid substation of the power company or from the tapping point to the traction substation. In this case, either of the methods a) and b) is selected, and both are not executed. The construction cost of c) is roughly proportional to the distance of the transmission line.

The transmission line tapping branch system, which is more economical, is recommended for the incoming system.

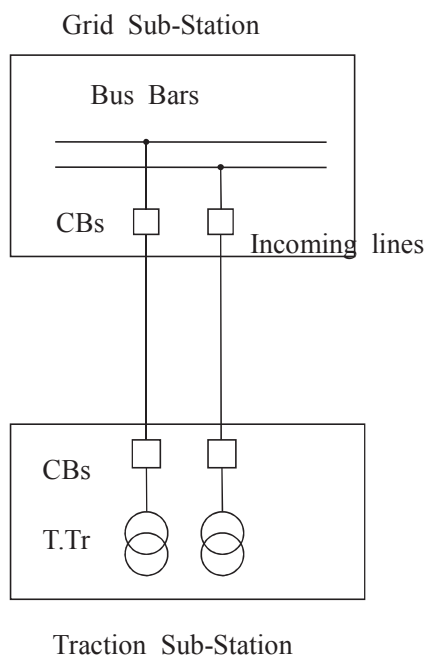

Figure 4.6-28  
A lead from the bus of grid substation of the power company

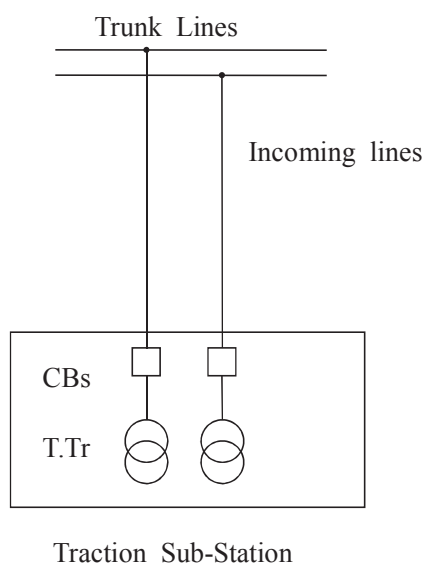

Figure 4.6-29  
Tapping from the transmission lines

## 3) Principal Specifications of the Traction Substation

India HSR shall have 2 x 25kV with AT feeding system because it can provide high-speed trains with high-power supply and have a characteristic which the interval between substations is longer than that of the other systems.

The principal specifications of the traction substation are listed in Table 4.6-22. For reference, the 2 x 25kV with AT feeding system section installed in the conventional line of Indian Railways is listed in the table. The distance of AT feeding system was 724 km. As its major section, BINA to KATNI (260 km) is described here. As shown in the table, Indian Railways have an experience that they have owned the 2 x 25kV with AT feeding system.

Table 4.6-22 Principal specifications of the traction substation

Items	HSR-1 (Draft)	Conventional line in India (BINA ~ KATNI Section)
Sub-station spacing (Average spacing)	55km (55 km)	81 ~ 98 km (87 km)
Incoming voltage	220 kV	220 kV
Nos of circuits	2	2
Traction transformer		
Transformer arrangement	Scott connection	Scott connection
Installed capacity	100 MVA	50 MVA
Nos of banks	2	2
Operation method	One is Common use. Another is on Standby	Same as left
Auto-transformers		
Installed capacity	15 MVA	8 MVA, 5 MVA
Auto-transformer spacing (Average spacing)	(13.8 km)	(14.4 km)

#### 4) Power Supply systems

##### Overall System

The study team obtained the power grid maps for the Maharashtra State and the Gujarat State so that the position of the traction substation (TSS) between Mumbai and Ahmedabad is temporarily set as shown in Figure 4.6-30 based on the conditions above and the draft alignment. A substation for a train depot is also temporarily set.



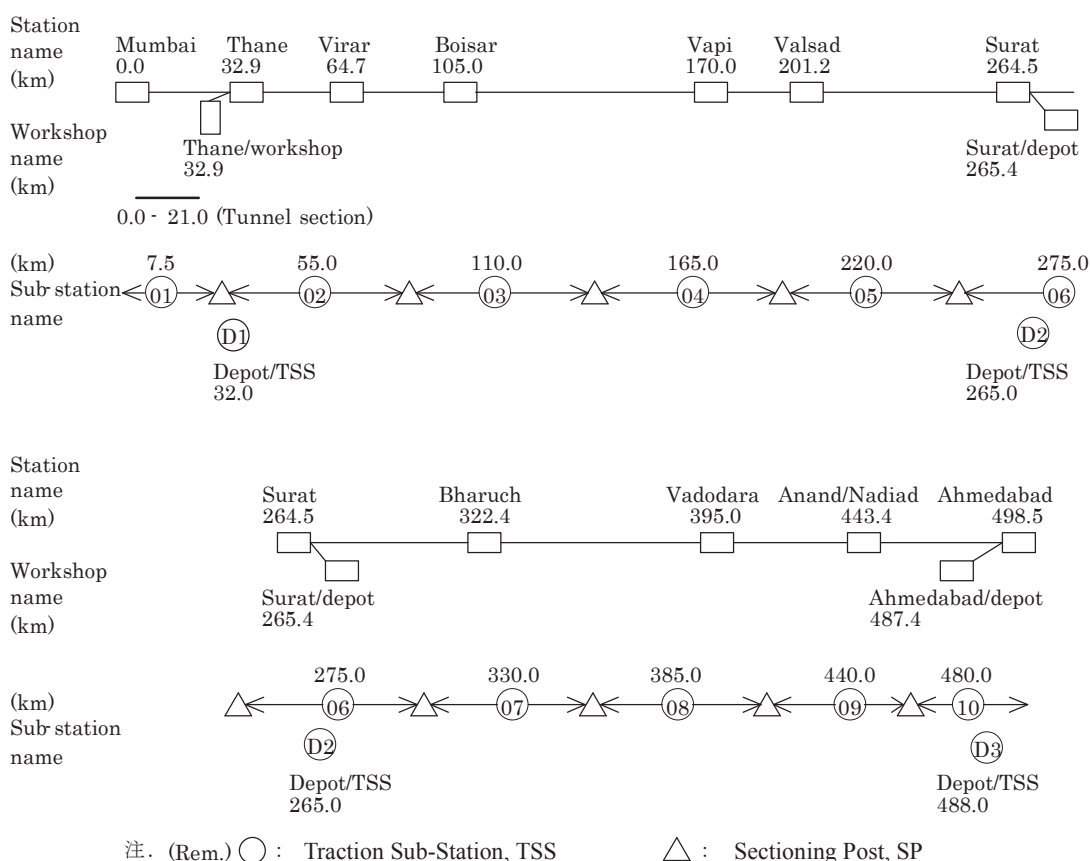

Figure 4.6-30 Power supply system (Mumbai to Ahmedabad) (Draft)

5) Overhead Equipment Installation Plan

As the overhead equipment in the Mumbai-Ahmedabad HSR, compound catenary system shall be adopted because its current collection is more stable than others and the current-carrying capacity seems to be large in high-speed operation and high frequency. Table 4.6-23 shows the main characteristic of the compound catenary system.

Table 4.6-23 Main characteristic of the compound catenary system

Items	Characteristics
Messenger wire	Galvanizing steel
Auxiliary messenger wire or stitch wire	Hard-Drawn copper
Contact wire	Bronze

#### 4.6.5 Signalling/Telecommunications

##### (1) Comparison/Analysis

Signalling & Telecommunications (S&T) is essential to perform safe, accurate, efficient and punctual operation and enhance traffic capacity for HSR. S&T has a lot of facilities such as Interlocking, Train Detection System, Automatic Train Protection (ATP) System, Motor Machine, Cable, Train Radio System and Carrier Communication System, etc. This section focuses on Signal type, ATP, Train Detection System and Train Radio System which has featured HSR and compares these systems among HSRs in the world.

##### 1) Signalling

First, this section has comparison with the systems introduced in the main HSR operating countries. Table 4.6-24 shows comparison of Signal type, ATP systems and Train Detection Systems.

Table 4.6-24 Comparison concerning Signalling for HSR in the world

	France	Germany	Italy	Spain	China	Taiwan	Japan	South Korea
	Cab Signal	Cab Signal	Cab Signal	Cab Signal	Cab Signal	Cab Signal	Cab Signal	Cab Signal
Signal type	Continuous control with one-step brake supervision	Continuous control with one-step brake supervision	Continuous control with one-step brake supervision	Continuous control with one-step brake supervision	Continuous control with one-step brake supervision	Continuous control with one-step brake supervision	Continuous control with one-step brake supervision	Continuous control with one-step brake supervision
Denomination of main Train Protection System	TVM430 ETCS L2	LZB ETCS L2	ETCS L2	LZB ETCS L1, L2	CTCS L3	Digital-ATC	Digital-ATC	TVM430 ETCS L1
Main train detection system	Non-insulated track circuit	Non-insulated track circuit Axle counter	Non-insulated track circuit	Non-insulated track circuit	Non-insulated track circuit	Non-insulated track circuit	Non-insulated track circuit	Non-insulated track circuit

Source: Study Team

##### ① Signal Type

Signal type can separate wayside signal type and cab signal type. Wayside signals are installed along the railway and they inform the driver whether the train should proceed ahead or stop. On the other hand, cab signal indicates allowable speed of the train and gives information about the track ahead at the monitor in the driver's cabin. All of the main HSR operation countries as shown in Table 4.6-21 have adopted cab signal. Cab signals can continuously receive the data concerning the allowable speed and the latest track state. That is, it has the cab indication to change at any time and to reflect any updates. If HSR has wayside signal only, the drivers can not recognize signal aspect and operate the train as usual. And, oversight of the wayside signal aspect may cause a serious accident when high-speed trains with more than 250km/h run.

In addition, cab signal has been paired with an ATP system, which can realize speed restrictions based on information received through the signal from signal equipment room.

##### ② ATP System

The main purposes to install ATP system in HSR are to prevent entry to wrong direction and route, excessive speed and train collision which are possibility to cause serious accidents. ATP system has two types, intermittent control type and continuous control type. Intermittent control type is updated at discrete points such as balises installed between rails and the monitor in the driver's cabin indicates information from the last update.

On the other hand, most of the HSR in the world have introduced the ATP systems with

continuous brake control because this type can continuously receive data concerning the allowable speed and the state of the track ahead. It can also provide excellent responsiveness, contributing high safety, high speed and high frequency.

In addition, continuous type can distinguish multi-step brake supervision type and one-step brake supervision type. Figure 4.6-31 and Figure 4.6-32 shows the brake pattern image of multi-step type and one-step type, respectively.

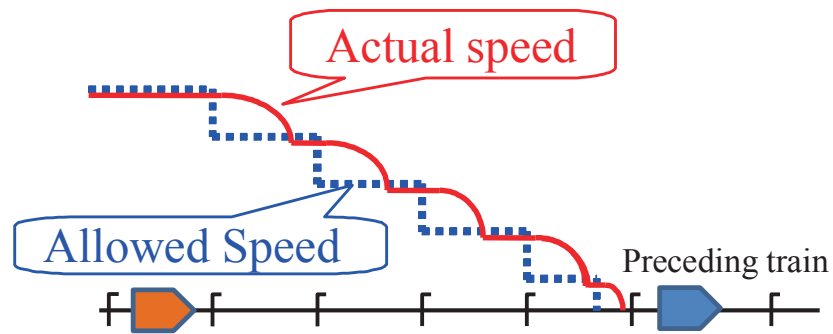

Source: Study team

Figure 4.6-31 Brake pattern image of multi-step brake supervision type

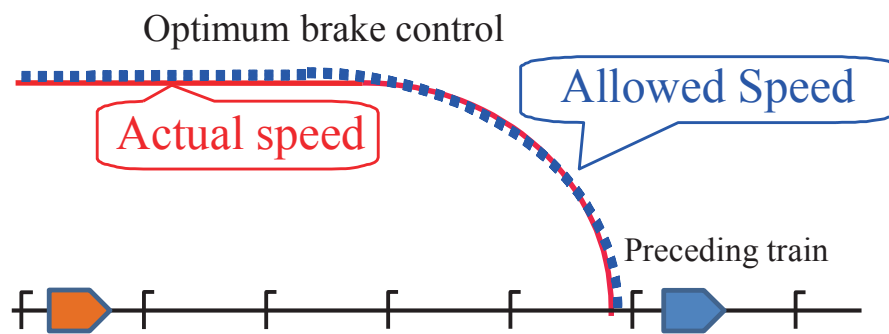

Source: Study team

Figure 4.6-32 Brake pattern image of one-step brake supervision type

The denominations of the main ATP systems for HSR in the world are ETCS Level-2, TVM430, LZB and Digital-ATC. These systems are continuous brake control type with one-step brake supervision. They can realize continuous transmission at high data volume and dynamic speed supervision by using digital data. The common point of them is to transfer “Movement Authority (MA)”, the permission distance the train can proceed, to the on-board ATP equipment and calculate or retrieve brake pattern in the on-board equipment. However, how to transfer the MA is different among the systems. ETCS Level-2 uses GSM-R, a digital radio network for railway. TVM-430 and Digital ATC transmit MA via rails. LZB basically makes use of conductive cable laid between rails.

### ③ Train Detection System

Almost HSR of the main countries is using track circuit as a train detection system, especially non-insulated track circuit using audio frequency. As one of train detection method, axle counter is also used.

## 2) Train Radio System

To realize high-level train operation, Train Radio System is installed in the world HSR. The system would provide wireless communication between dispatchers in OCC, train crews and operation and maintenance (O&M) staffs.

Table 4.6-25 shows comparison of Train Radio Systems in the world. And, Figure 4.6-33 shows frequency band of each Digital Train Radio System used in HSR today.

Table 4.6-25 Comparison of Train Radio System in the world

	France	Germany	Italy	Spain	China	Taiwan	Japan	South Korea
Train Radio System	Space-wave radio	Space-wave radio	Space-wave radio	Space-wave radio	Space-wave radio	Space-wave radio	LCX	Space-wave radio
	Digital	Digital	Digital	Digital	Digital	Digital	Digital	Analog
Denomination of Train Radio System	GSM-R	GSM-R	GSM-R	GSM-R	GSM-R	TETRA	Dedicated type using LCX	TRS

Source: Study team

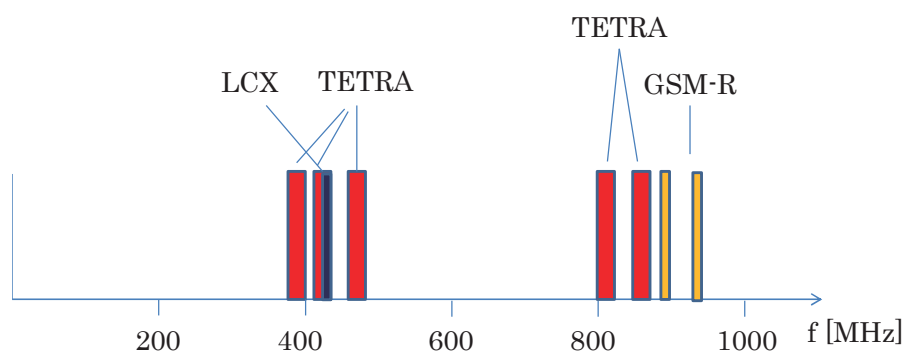

2.4GHz ··· CBTC, Wireless LAN

Source: Study team

Figure 4.6-33 Frequency band of each Train Radio System used in HSR today

In almost of HSR in the world, Digital Train Radio System is introduced. It can provide a lot of data communication channels to support the operation, failure recovery and maintenance requirements of the railway system. The system uses 300 MHz to 3 GHz of Ultra High Frequency (UHF) band being suitable for mobile communication.

In space wave radio type used in HSR today, the function of TETRA is more competitive in respect of transmission efficiency, connection speed and cell size than that of GSM-R. The dedicated type using LCX is implemented with a narrow frequency band of 2 waves and various functions such as command transmission, vehicle support and passenger information could be used. Incidentally, the dedicated type using LCX can use antennas and change to space radio type in open sections as the same number of pairs of frequencies as the system using LCX only.

(2) Recommendation

1) Signal type

India HSR shall install cab signal system which indicates the allowable train speed and gives track head information in driver’s cabin. The high-speed train runs at over 250 km/h so that it is physically difficult for the driver to visually confirm the signal and make decision on his/her own to apply the brake. Cab signal can also enhance traffic capacity compared to the operation by wayside signal because driver’s visibility for signal aspect is not necessary in cab signal.

Cab signal has been a part of an ATP system that can automatically apply the brakes and bring the train to a stop if the driver does not respond appropriately to a dangerous condition.

A cab signal monitor is an interface between driver and cab signal system as the image shown in Figure 4.6-34.



Source: JR East

Figure 4.6-34 Image of cab signal monitor in driver’s cabin

2) ATP System

India HSR shall install an ATP system to apply the brake automatically based on the distance from the stop point decided by the preceding train position and the evaluation of various conditions, especially the system having continuous brake control with one-step brake supervision.

The systems which are applied among the railways in the world can be generally classified into five groups with respect to their function and the type of transmission according to “Railway Signalling & Interlocking”, Eurailpress, 2009 as shown in Table 4.6-26.

Table 4.6-26 Categorization of ATP System

functions Transmission	attentiveness check, train stop function and others, but without brake supervision	with brake supervision, but without dynamic speed profile	dynamic speed profile
intermittent	Group 1	Group 2	Group 4
continuous	Group 3		Group 5

Source: “Railway Signalling & Interlocking”, Eurailpress, 2009

The systems belonging to Group 1 have intermittent transmission and without braking

supervision. These systems mainly provide the driver with audio-visual warning and prevent him from passing a signal at danger. The train brakes are applied automatically if the driver fails to control the train based on the signal aspect.

Group 2 has intermittent transmission at low data volume and with braking supervision. In these systems, the braking process is supervised, but without calculating a dynamic speed profile.

Group 3 are systems having continuous signal transmission with multi-step brake supervision every block. These systems transmit the frequency correspond to the signal aspect to on-board equipment through rails, etc. Trains can receive the newest information by each block and update the on-board information. They prevent the driver from forgetting signal aspects and enable an immediate reaction if the signal aspect changes. In this type, ground equipment decides the allowed speed in accordance with the lowest deceleration train. Speed signal changes every block so that brake pattern becomes multi-step. Travel time and train headway are longer and train brake performance is not more effective than that of Group 4 and Group 5.

Group 4 and Group 5 are systems to realize sophisticated train control. Recent digital technology makes ATP Systems more sophisticated, which is better train control because the on-board device can deal with a lot of data. In these systems, the ground equipment sends "Movement Authority (MA)", which is including stopping point data and shows the permission distance the train can proceed, by digital signal. After receiving the MA information, the on-board device calculates single-step braking pattern or retrieves it from on-board database and the system automatically controls train speeds based on the brake pattern. In these systems, Group 4 is intermittent transmission type with high data volume and dynamic speed supervision such as ETCS Level-1. Group 5 are continuous transmission type at high data volume and dynamic speed supervision.

Because high-speed train proceeds at the speed of more than 70m per second and the running situation momentarily changes, it is desirable that high-speed train continuously receive signal at all times for safety. Continuous brake control type such as Group 3 or Group 5 gives excellent responsiveness, contributing high safety, high speed and high frequency. Especially, the Systems of Group 5 can realize continuous brake control with one-step brake supervision by using the state-of-the-art digital technology. They can reduce travel time, shorten train headway and make passengers more comfortable due to the one-step brake supervision. ETCS Level-2, TVM430, LZB and Digital-ATC belonging to Group 5 shall meet requirements in India HSR.

## 2) Train Radio System

Train Radio System shall have wireless communication between dispatchers in OCC, train crews and operation and maintenance (O&M) staffs. Now, digital radio system is regards the mainstream today. Digital Train Radio System can send a lot of data with high-speed transmission between ground equipment and on-board equipment, which is necessary for high level communication in high speed train operation. It can also have coherent communication with ground digital synchronous network and digital modulation can use frequencies effectively as advantage.

There are two types in the proven Digital Train Radio Systems used in the world, the space radio type such as GSM-R and TETRA and the dedicated type using LCX. The space radio type needs to have monopole antennas along HSR line. Although GSM-R and TETRA can have a few numbers of wayside facilities, they have to secure several frequencies and switch the channels to avoid interference at a border area. In addition, it is possibility that a non-receiving zone and interference are easy to occur by existence of building and topography conditions.

On the other hand, the dedicated type using LCX lays LCX cable with slots in the outside of coaxial cable and leaks electric wave along HSR line. It has many advantages of having clearer voice communication and many data channels with minimum frequencies although a number of wayside facilities increases compared to GSM-R and TETRA. Figure 4.6-35 shows an example of layout of LCX cable. Incidentally, the dedicated type using LCX can use antennas and change to space radio type in open sections as the same number of pairs of frequencies as the system using LCX only.



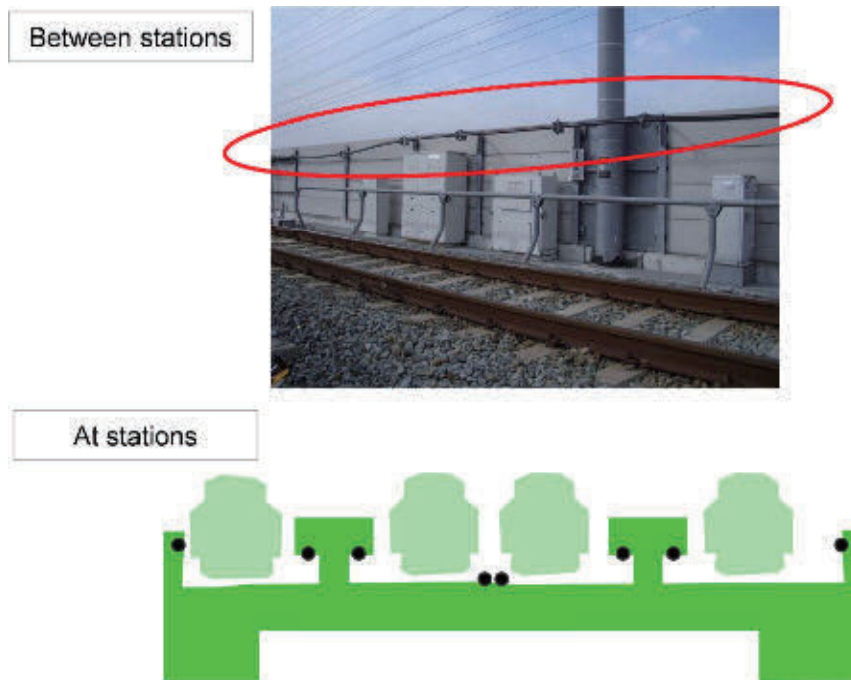

Source: JR East

Figure 4.6-35 Layout of LCX Cable

In India HSR, one of Digital Train Radio Systems shall be introduced in consideration of a kind of ATP system. However, India HSR has an acute concern about frequency. An introduced radio system in the future is requested to work within 1.6MHz wide range of 900MHz band regulated by the Wireless Planning and Co-ordination (WPC).

India HSR shall install train radio systems with digital transmission such as GSM-R, TETRA and the dedicated type using LCX.

## 4.6.6 Rolling Stock

### (1) Comparison/Analysis

#### 1) Basic factors of HS rolling stock

There are a variety of HS rolling stock series in the world, because specifications of HS rolling stock have depended on not only technological factors but also the geographical conditions of where the high speed train is operated. The basic factors and dimensions which feature HS rolling stocks are track gauge: this item is considered minutely in 4.4-2; maximum operation speed, traction system; Train-set formula, body width and body materials. Table 4.6-27 shows typical series of HS rolling stocks in major countries from the view point of basic factors.

Table 4.6-27 Typical series of World HS rolling stocks

Country	Japan	France	Italy	Germany	Spain	South Korea	Taiwan	China
Maximum operation speed	320 km/h	320 km/h	300 km/h	300 km/h	300 km/h	300 km/h	300 km/h	300 km/h
Train-set formula	EMU	Loco	Loco / EMU	Loco / EMU	Loco / EMU	Loco	EMU	EMU
Car-body width (mm)	3350- *1) 3380	2814- 2904	2750- 3000	2950- 3020	2830- 2960	2904- 2970	3380	3200- 3380
Typical series	E5	TGV-R	AGV	VelaroD	S103	KTX-II	700T	CRH 380A
Formula	EMU	Loco	EMU	EMU	EMU	Loco	EMU	EMU
Body-material	Aluminum	Steel	Aluminum	Aluminum	Aluminum	Aluminum	Aluminum	Aluminum
Passenger capacity (seats)	731	375	450	444	403	363	989	480
Power (kW)	9600	8800	7500	8000	8800	8800	10260	9600
Power/seats (kW/seats)	13.13	23.47	16.67	18.01	21.84	24.24	10.37	20.00

Note: \*1. Mini-Shinkansen types are excluded.

Source: Compiled Study team based on UIC data

#### 2) Maximum speed

As mentioned before, HSR in the world have realized train operation at the maximum speed of 320 km/h on standard-gauge tracks and the world mainstream of maximum operation speed is from 300 km/h to 320 km/h.

#### 3) EMU or Loco system regarding power system?

HS trains at the maximum operation speed of over 300 km/h normally use fixed train sets, while combining two sets into one as necessity arises to cope with fluctuation of transport demands. Regarding power distribution of these fixed train sets, there are two types. One is concentrated power system; Loco system; adopted by such as TGV in France, high speed train based on TGV-R: Spain Renfe S100 and South Korean KTX-I,II; and ICE-1 at its initial stage in Germany. And the other is distributed power system adopted by Japan, China and ICE-3 in Germany for its latest train compositions.

In conventional railway, Loco system was a main stream of long distance train in Europe and it realized fairly high speed. Regarding HS trains, formerly each type: Loco and EMU: had advantages and disadvantages in some view points and they have been used respectively in accordance with their role. Recently as the maximum operation speed is increasing, adoption of EMU system become dominant, because advantages of EMU have exceeded. The followings are advantages of EMU system.

##### ➤ Traction performance & traveling time

The main aim of HS train is to reduce travelling time between stations, acceleration/deceleration performance is a particularly important factor especially for running short distance and having many

stops. Traction force depends on adhesion force between a rail and wheel. Weight of locomotive is restricted, so resulting restriction of traction power. EMU have a lot of comparatively small power system but the total is over locos' power. EMU has greater acceleration/deceleration performance, due to utilizing effectively adhesion force. EMU realize acceleration over 2.0 km/h/sec, while Loco under 1.0 km/h/sec, resulting shorter traveling time.

➤ Passenger capacity

Passenger capacity is one of most important factors of HS rolling stock. Higher capacity is an advantage for profitability on HSR, as long as it doesn't infringe passenger comfort. Locomotive cars are not available for passenger space, while all of EMU can accommodate passenger. Therefore EMU can have higher passenger capacity. Comparison of passenger capacity among typical HS rolling stocks under same train-length condition is shown in table 4.6-28. The difference of passenger capacity between TGV-R and ICE-3 is caused from the difference between Loco and EMU type. EMU has higher capacity than loco by 20 % approximately. The difference between E2 and ICE-3 results from the difference of body-width, it will be described in another section later.

Table 4.6-28 Comparison of passenger capacity

Series	TGV-R (France)	ICE-3 (Germany)	E2 (Japan)
Type	Loco	EMU	EMU
Train-length	200m	200m	200m
Body-width	2904 mm	2950 mm	3380 mm
Passenger capacity	375 seats	444 seats	630 seats

Source: Compiled by Study team based on UIC data

➤ Energy efficiency

Energy efficiency directly affects operation cost and also reduction in CO2 emission. Regenerative braking is essential to reduce energy consumption and is used to instead of mechanical brakes for stopping a train.

Same as traction power, regenerative braking power of locomotives is not enough to stop a train smoothly, coaches of a train set need to use mechanical braking system which wastes braking energy. On the other hand, EMU has enough regenerative brake power due to multiple power system equipped. Regenerative ratio of EMU is higher than that of loco system.

➤ Maximum axel load

Locomotive car's axel load is heavier than that of EMU because it needs larger adhesion force which relates to axel load. The heavier axel load gives the larger stress on rail and civil infrastructure, and it results in increasing maintenance and construction cost.

EMU has realized maximum axel load under 14 tons, while Loco have remained about 17 tons.

➤ Redundancy of main component

EMU has multiple main components; it might be able to operate in spite of one or two units break downs. EMU has higher redundancy than loco system.

➤ Maintenance of rolling stock

Formerly, power system needs a great quantity of maintenance. In recent years, thanks to progress in the field of power electronics; AC motors with IGBT/VVVF controllers which are almost without maintenance are now mainstream; it reduced maintenance work and cost of power system. And regarding EMU, the interval of maintenance for mechanical braking system is prolonged due to utilization of regenerative braking. The deference of maintenance cost between EMU and loco system is not so much at present.

➤ Flexibility of train set

Whichever type is adopted-EMU or Loco-, solid configuration of train set is recently used for HS trains. For flexible train services, automatic coupling systems to connect two train sets mechanically

and electrically is developed. Flexibility is same in both types.

➤ Riding comfort

Loco system has an advantage in riding comfort because power system and other equipment which generate noise and vibration are not installed on passenger coaches. As technical development is proceeding such as power system, reduction/ insulation against noise and vibration and so on, the difference is decreasing.

Figure 4.6-36 shows types of HS trains, EMU or Loco system. Formerly Loco system is adopted for HS trains mainly in Europe. As the increasing maximum operation speed, the recent design trend is toward distributed power system-EMU-due to several advantages mentioned above.

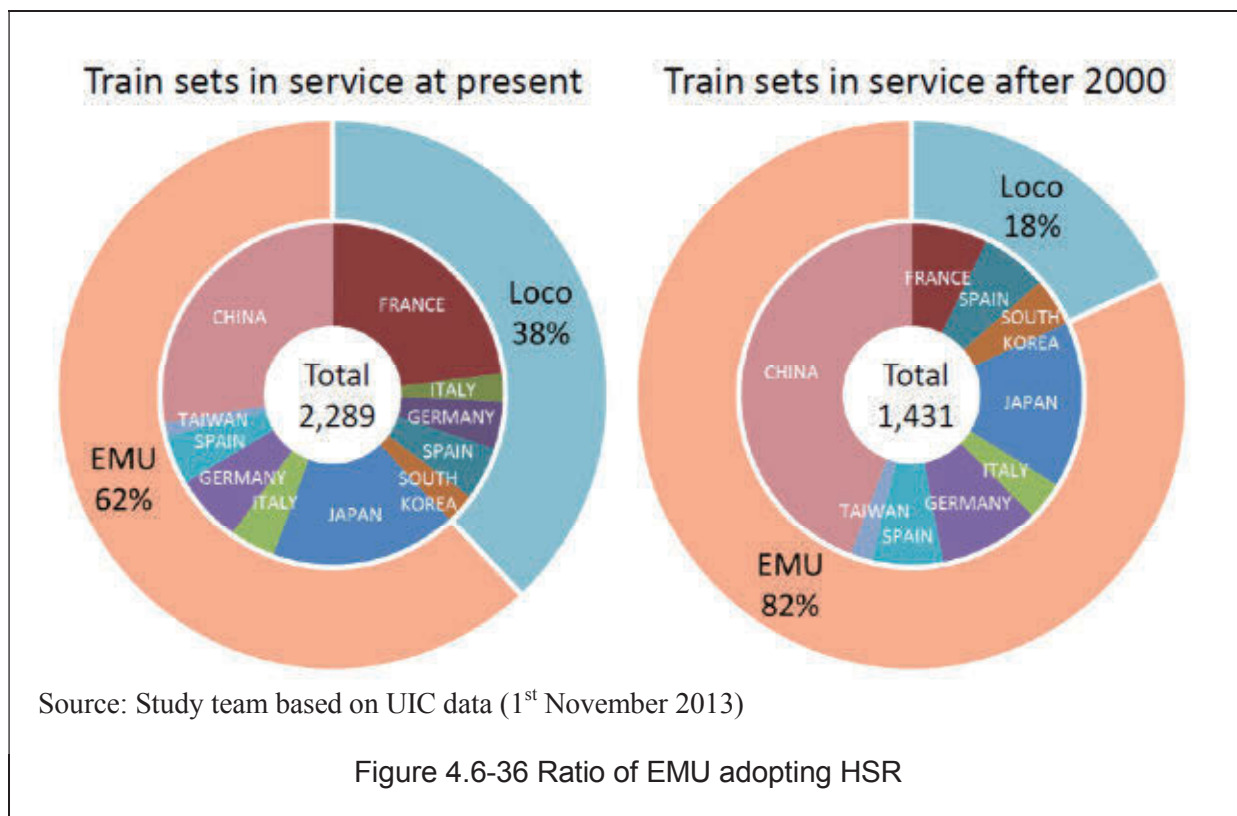

- Germany changed adopting design from Loco type (ICE-1, 2) to EMU since 2000 at the inauguration of ICE-3.
- China has decided design policy that EMU system should be adopted for HSR at the beginning of HSR development in 2004.
- Alstom which is the supplier of TGV: one of the most famous Loco systems for HSR: has already developed AGV which is next-generation HS train under the distributed traction system.

The recent mainstream of HS train is adopting EMU system.

3) Loading gauge, Car body width and Seat arrangement

➤ Loading gauge

The loading gauge means a contour of rolling stock (maximum height and width) to guarantee safety of train operation against bridges, tunnels and other structures. Table 4.6-29 shows maximum body width of Rolling stock. In Europe, there are three types of loading gauge, A, B and C, for standard-gauge railways, of which the type C (width 3,150 mm) is normally used for high-speed railways. The rolling stock gauge used for HSR in Japan, 3,400 mm in width is wider than the above-mentioned type C rolling stock gauge in Europe.

Table 4.6-29 Maximum body width of rolling stock in typical HSR

Unit: mm

Country	Track gauge	Max. body Width of RSs
<b>Japan (HSR)</b>	1435	3350~3380
<b>France</b>	1435	2896~2904
<b>Germany</b>	1435	2950~3020
<b>Italy</b>	1435	2750~3000
<b>Spain</b>	1435 or 1668	2830~2960
<b>China</b>	1435	3200~3380
<b>Taiwan</b>	1435	3380
<b>South Korea</b>	1435	2904~2970
<b>India (Conventional)</b>	1676	3240~3250

Source: JICA Study Team based on UIC data.

➤ Car body width and seat arrangement

The loading gauge widely used for high speed railways in Europe is the “UIC loading gauge, type C,” to limit car body width to 3,150 mm or less. Therefore, standard cars have a car body width of 3,000 mm or less, with ordinary train sets designed to a structure having 4-seats arrangement (two 2-seats arrangement). In contrast, Japan, China and Taiwan adopted a loading gauge to make the car body width 3,400 mm or less to make 5-seat arrangement (2-seats/3-seats arrangement) possible shown in Table 4.6-30.

Series E4: Japanese double-decker HS rolling stock: which accommodate the most seat-capacity in world HS trains as recorded in Guinness book, have 6-seat arrangement (two 3-seats arrangement), with armrests equipped only at the aisle side of 3-seats arrangement. While comfort is downgraded and the aisle width is made smaller in this design, it might be one option which provides lower-price seats. Figure 4.6-37 shows seat arrangement of 5 or 6 seats arrangement. To realize 6-seats arrangement with comfort kept unchanged, the car body width shall be extended beyond 3,400 mm, which hasn’t been experienced yet in the world. It is far from practical that body width over 3400 mm shall be adopted because it is not proven in HSR at the moment.

Table 4.6-30 Loading gauge and car body widths adopted in HSR

Country	Japan		France		German		Italy		Spain		China		Taiwan	South Korea
Class	Series E5	Series E4	TGV -R	TGV -D	ICE1	ICE3	ETR -500	AGV -Itaro	S100	S103	CRH -2C	CRH -3	700T	KTX - I
Car body width (mm)	3350	3380	2904	2896	3020	2950	2860	3000	2904	2950	3380	3260	3380	2904
Seat arrangement (Ordinary Car)	2+3	3+3 2+3	2+2	2+2	2+2	2+2	2+2	2+2	2+2	2+2	2+3	2+3	2+3	2+2

Source: Study team



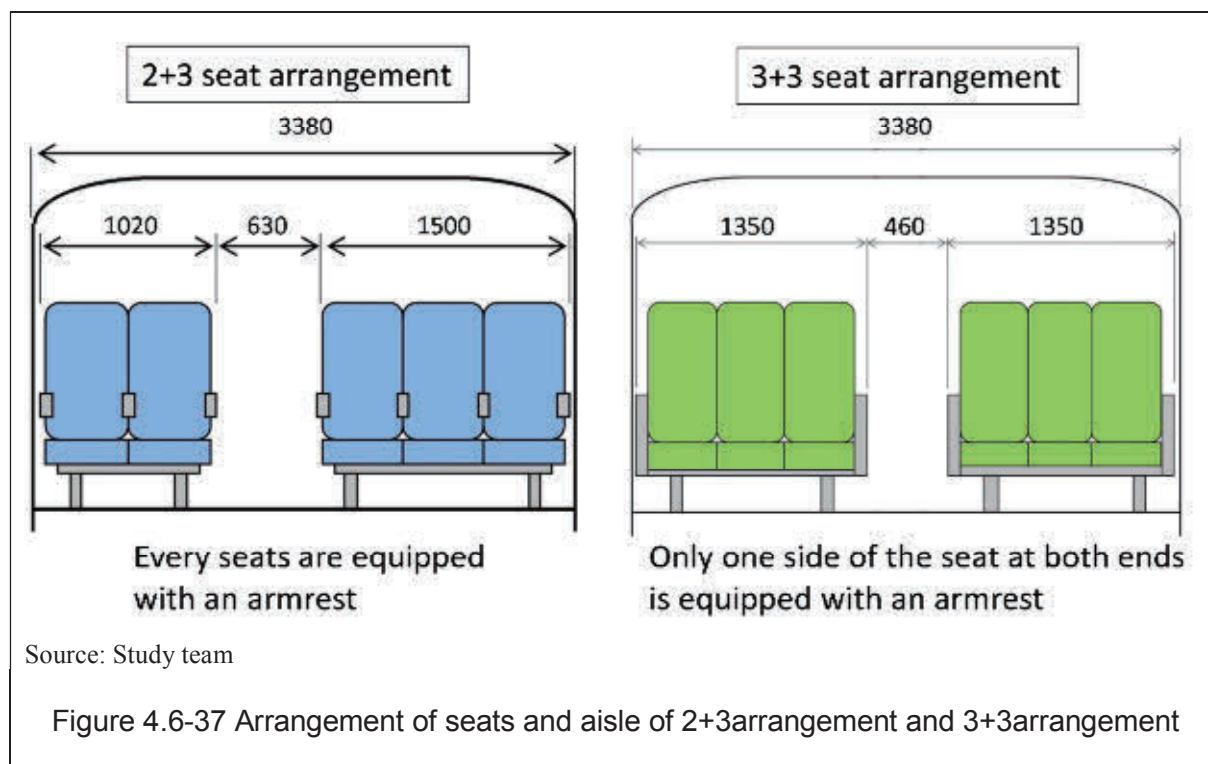

#### 4) Car body materials

Among the high-speed railways in the world, some of the car bodies are made of steel like French TGV-R and high speed train based on TGV-R: Spain Renfe 100 and South Korean KTX-I: and an aluminum alloy with others including TGV-D which was required for light weight double-decker as shown in Table 4.6-31. KTX-II, which is the latest series of HSR in South Korea, also adopted aluminum alloy to its body materials.

Aluminum alloy is lighter than steel, also aluminum alloy is highly resistant against corrosion. So aluminum alloy is mainly used for HSR which strongly requires light weight body structure.

Table 4.6-31 Materials used for car body structures in different countries

Country	Japan		France		German		Italy		Spain		China		Taiwan	South Korea
Class	Series E5	Series E4	TGV -R	TGV -D	ICE1	ICE3	ETR -500	AGV -Itaro	S100	S103	CRH -2C	CRH -3	700T	KTX - I
Car body material	Aluminum alloy	Aluminum alloy	Steel	Aluminum alloy	Aluminum alloy	Aluminum alloy	Aluminum alloy	Aluminum alloy	Steel	Aluminum alloy	Aluminum alloy	Aluminum alloy	Aluminum alloy	Steel

Source: Study team

### (2) Recommendation

#### 1) Maximum operation speed

High-speed trains are performing revenue service operation at from 300 km/h to 320 km/h on standard-gauge tracks dedicated to high-speed operation in various countries across the world. Increase in the maximum operation speed not only reduce the travel time to the destination, thereby improving the convenience of passengers, but also raise the rolling stock utilization efficiency, thus providing merits to reduce the number of train sets required for revenue service. On the other hand, in performing high-speed operation, if an operational speed of train is over 320km/h which is not proven, considerable time will be required for verification and validation, in order to check the safety and reliability. It is also necessary that the operator take into account of increasing energy consumption, environmental loads and maintenance cost by over 320km/h operational speed.

Therefore, it is recommended the maximum speed in revenue service operation should be 320 km/h on the proven standard-gauge tracks at inauguration and it would be increased in the future, confirming safety and reliability.



## 2) EMU or Loco system regarding power system?

Loco system is defined as a train set equipped with concentrated power system and EMU, Electric Multiple Unit, as a train set equipped with distributed power system. Their advantages and disadvantages are resulted from the difference of power system formulation.

Loco system, which had been used to conventional long distant trains in Europe, has some advantages such as less maintenance work and riding comfort and it was used for even HSR at the beginning time of HSR.

As the higher maximum operation speed is increasing, the more advantages of EMU are recognized in according with technical development in power electronics and others.

Now EMU, distributed power system, is the mainstream of power system for HSR. Even Alstom (TGV's supplier) has also adopted the power distribution system for its next-generation train sets against its adherence to the concentrated traction system in the past.

Under the circumstances, therefore, it is recommend that distributed traction type fixe train sets will be adopted for its high-speed railways in India.





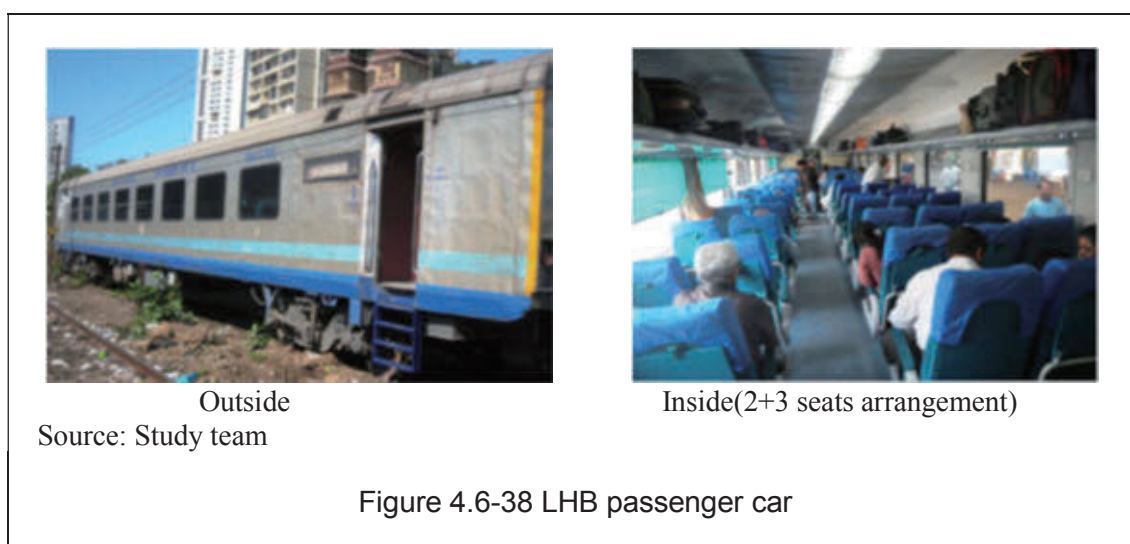

## 3) Car body width and seat arrangement

HSR requires top-class service and riding comfort should be realized further improving than conventional trains. The LHB type passenger cars, high-specifications passenger cars that can run at a maximum speed of 160 km/h, have 1st and 2nd class cars, having two 2-seats arrangement and 2-seats/3-seats arrangement respectively.(Figure 4.6-38)



Among HSRs in the world, HS trains in Japan, China and Taiwan have realized mass transport with 2-seat/3-seat arrangement shown in Table 4.6-32. To provide better quality of service, maintaining passenger capacity with the same seat arrangement, it is recommended wider body (3240~3400mm) should be adopted to HSR in consideration of the physical structure of Indian people and the size of baggage they carry in the passenger cabin. (Figure 4.6-39)

Table 4.6-32 Car body width and Seat dimensions

	Series E5	ICE3	CRH-2C	CRH-3	700T	LHB coach
Class						
Car body width	3350mm	2950mm	3380mm	3260mm	3380mm	3240mm
Width of 3-seat	1530mm	/	1480mm	<1480mm	1520mm	1492mm
Width of 2-seat	1002mm		1015mm	<1015mm	1010mm	1002mm
Width of aisle	570mm	500mm	600mm	500mm	600mm	556mm
Seat pitch	1040mm	920mm	980mm	<980mm	1040mm	990mm

Source: Study team

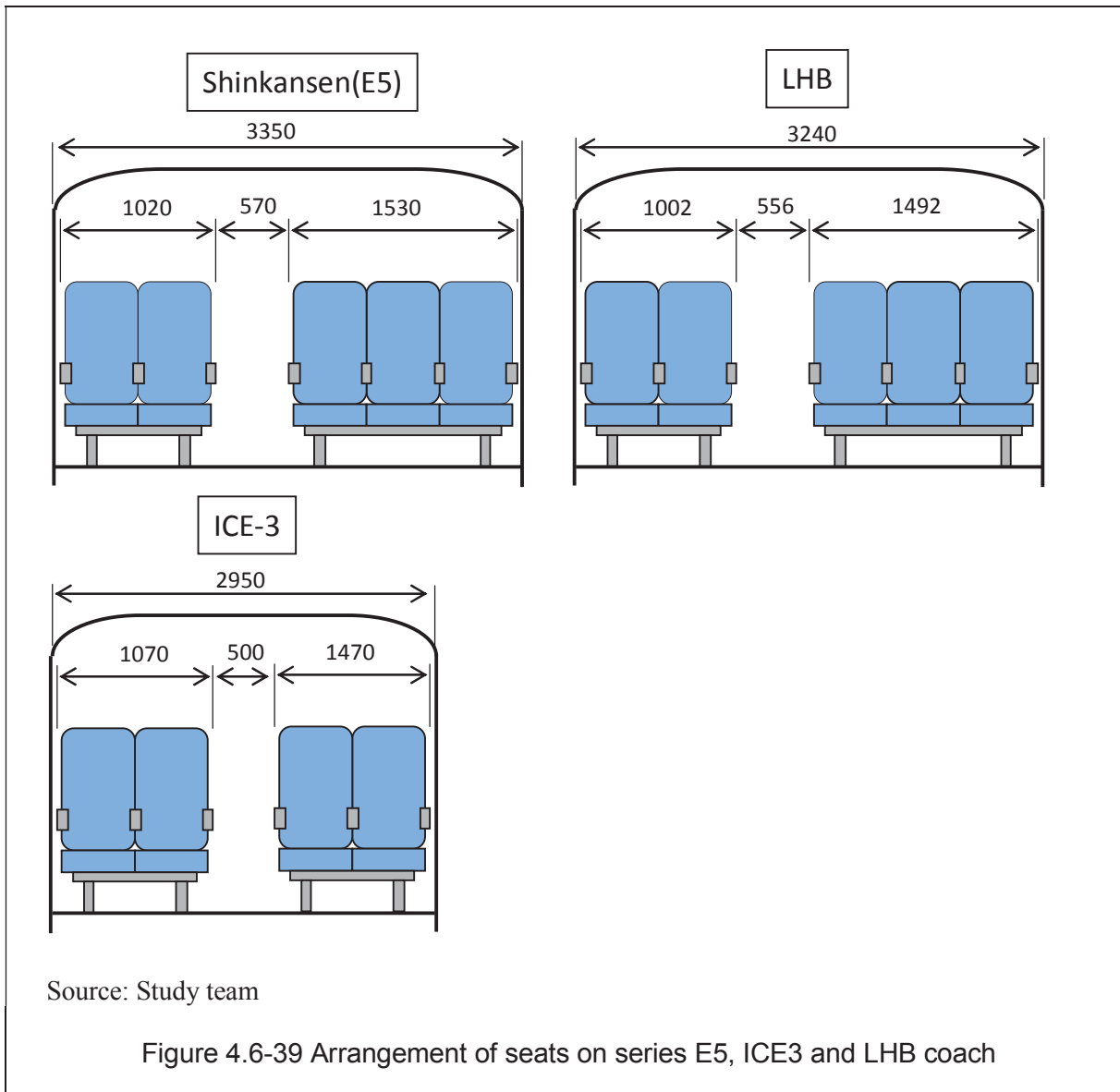

Source: Study team

Figure 4.6-39 Arrangement of seats on series E5, ICE3 and LHB coach

#### 4) Materials of car body structure

Regarding the materials for car bodies, aluminum alloys are used for most of world HS trains at present. TGV series and a number of other cars based on TGV: Renfe S100 and KTX-I: had used steel for its body materials for a long time, however double decker TGV-D that required weight reduction was made of aluminum alloy.

Heavier axle loads give more intense vibration to tracks and track bed and increase energy consumption in running, so the aluminum alloy is effective. Moreover an aluminum alloy is highly resistant against corrosion, so maintenance for car body is easy.

Also the manufacturing cost of aluminum alloy has been cut by the development of aluminum double-skin material manufacturing technology using a hollow-type large extrusion process along with the adoption of friction stir welding (FSW) method.

For trains to pass tunnels at high speed, the car body needs to be airtight to prevent discomfort of passengers (so-called sudden ear pops) due to pressure changes in tunnel. It is essential, therefore, that the rolling stock structure be welded seamlessly.

Judging from such precedent cases, the car bodies of high-speed rolling stock should be made of aluminum alloys that realize light weight and facilitate an airtight structure.

#### 5) Summary of Recommendation

Based on comparison and analysis of world HS rolling stocks, recommendation is summarized in below.

- Regarding train formation, EMU type should be adopted
- To put the rolling stock into operation on the proposed section, the maximum operation speed at 320 km/h is appropriate and will be increased in the future, confirming safety and reliability.
- Wide body type, Car body width from 3200mm to 3,400 mm, should be selected for providing more comfort keeping passenger capacity with a formation of 5-seats arrangement. It can also realize two 3-seats arrangement.

Table 4.6-33 summarizes recommendation for HS rolling stock

Table 4.6-33 Recommendation for Rolling stock dimensions and specifications

Item	Dimension	Remarks
Train Type	EMU	
Formation	8 to 16 cars (tentative)	To be revised based on passenger demand forecast
Maximum operation speed	320 km/h	At inauguration
Car body width	3200~3,400mm	Wide body type
Seat arrangement	5-seat arrangement (2-seat/3-seat arrangement)	Standard car
Car body materials	Aluminum alloy	Airtight structure

Source: Study team

## 4.7 Alignments & Station Location

### 4.7.1 Workflow of Comparison of Alignments and Station Locations

Workflow of comparison of alignments and station locations are shown in Figure 4.7-1. The site survey and stakeholders meeting were carried out, and a joint meeting with State Governments of Gujarat and Maharashtra, Regional Officers, organized by Ministry of Railway was held based on comparison of alignments and station locations on 2<sup>nd</sup> April.

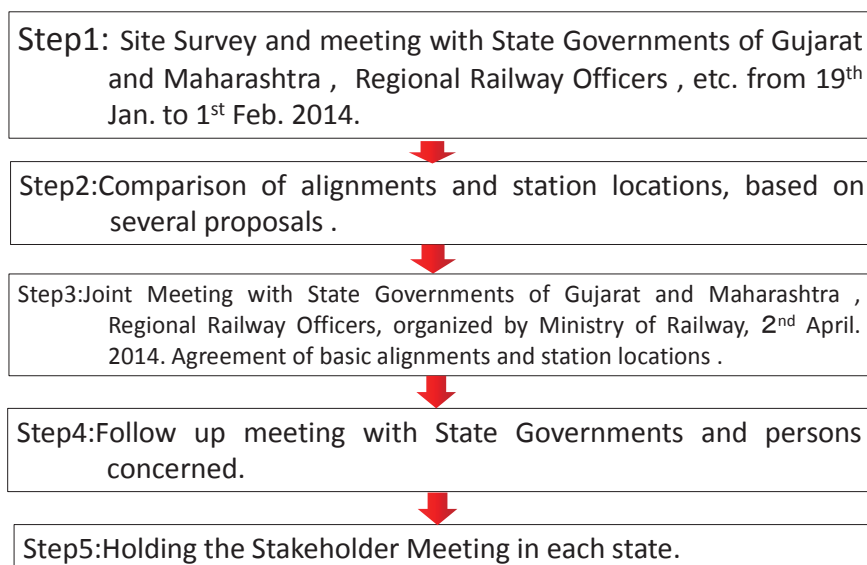

Source: Study team

Figure 4.7-1 Workflow of Comparison of Alignments and Station Locations

### 4.7.2 Site Survey and Meeting with State Government and Local Railway Bureaus

#### (1) Site survey plan and meeting with state government and local railway bureaus

20 JICA Study team members carried out site survey from Mumbai to Ahmedabad (from January 19 to February 1) along the proposed stations and alignments of HSR. The teams held several meetings with concerned departments and agencies (of both states, Gujarat and Maharashtra, and also with Central Govt. agencies and MOR etc) and exchanged views with them. The team also collected data and information required for planning of HSR.

1<sup>st</sup> Survey Schedule of Study Team on India High Speed Railway Project Line 1 (January-February, 2014) is as follows:

Table 4.7-1 1st Survey Schedule of Study Team

Date		Seq.	Route Survey Team1
January. 19	Sunday	1st	PM: Delhi 16:35 → Mumbai 18:30 (JET Airways 334)
January. 20	Monday	2nd	<p>Western Railway (General Manager) Western Railway (Operations Division) Western Railway (Transportation Planning Division)</p> <p>Central Railway (General Manager) Central Railway (Operations Division) Central Railway (Transportation Planning Division)</p> <p>Government of Maharashtra (Chief Secretary) Government of Maharashtra (Transportation Department) Government of Maharashtra (Public work Department) Government of Maharashtra (Urban Department) Government of Maharashtra (Planning &amp; Administration Department)</p> <p>Mumbai Metropolitan Region Development Authority (Transport &amp; Communication Division)</p> <p>(Site Survey in Mumbai)</p>
January. 21	Tuesday	3rd	Site Survey in Mumbai
January. 22	Wednesday	4th	Route Survey from Mumbai to Virar
January. 23	Thursday	5th	Route Survey from Mumbai to Virar
January. 24	Friday	6th	Route Survey from Mumbai to Dahanu
January. 25	Saturday	7th	Route Survey from Dahanu to Surat
January. 26	Sunday	8th	Preparation of materials, etc.
January. 27	Monday	9th	Route Survey from Surat to Vadodara
January. 28	Tuesday	10th	Site Survey in Vadodara Western Railway (Vadodara Divisional Railway office)
January. 29	Wednesday	11th	Route Survey from Vadodara to Ahmedabad
January. 30	Thursday	12th	Preparation of materials, etc.
January. 31	Friday	13th	<p>Government of Gujarat (Chief Secretary) Government of Gujarat (Planning &amp; Administration Department) Government of Gujarat (Urban Department &amp; Urban Housing Department) Government of Gujarat (Road &amp; Building Department) Government of Gujarat (Gujarat Urban Development Company)</p> <p>GIDB(Gujarat Infrastructure Development Board) Deputy Manager</p> <p>Western Railway (Ahmedabad Divisional Railway office)</p> <p>(Site Survey in Ahmedabad)</p>
February. 1	Saturday	14th	Site Survey in Ahmedabad PM: Ahmedabad 17:00 → Delhi 18:25 (Indigo 165)

## (2) Main meetings

### 1) State of Maharashtra (24/01/2014)

Participated Members of State Maharashtra are as follows:

Mr. Jageshwar S. Saharia(Chief Secretary, Govt. of Maharashtra)	GOM
Dr. S.K. Sharma ( Principal Secretary, Transport and Ports)	GOM
Mr. Praveen Singh Pardeshi ( Principal Secretary, Forest )	GOM
Officers form Principal Secretary, Urban Planning, Principal Secretary, and Public Works Dept.	GOM

Main points of this meeting are as follows:

- Earlier study was to include Pune on the HSR corridor which is an important city of Maharashtra. In Gujarat, three major cities Ahmedabad, Vadodara and Surat will have stations and unless Pune in Maharashtra is not connected than it will not be attractive proposition for Maharashtra State.
- Mr. Saharia advised to have state and local level monitoring committee to be formed for the discussion on the corridor and at some stage district level committee also will come in picture and from railways both central and western railways should be part of monitoring committee.
- A benefit of the project should be made clear as lot of land in Mumbai and Thane will be involved in the corridor along with rehabilitation and resettlement issues.
- Mr. Saharia said the concept is encouraging, asked the team to provide some more details to Government of Maharashtra and also asked about MOR, Urban Planning Commission's view on the corridor.
- The alignment seems to be good and does not see any environmental issue at the moment.
- It was advised to keep the alignment at least one KM away from the Sanjay Gandhi national park and sanctuary.
- Dr. S.K. Sharma (Principal Secretary, Transport and Ports) was appointed as a nodal officer for this study.

### 2) Govt. of Gujarat State (31/01/2014)

Participated Members of State Gujarat are as follows:

Mr. A.K.Sharma (Additional Principal Secretary to Chief Minster, Govt. of Gujarat State./Chief Executive Officer, Gujarat Infrastructure development board)	GIDB
Ms. Swati J. Buch (General Manager)	GIDB
Mr. Amit Chavda (Senior Manager)	GIDB
Ms. Mona Khandar (Secretary of Urban Housing and Urban Development Department Govt. of Gujarat State)	

Main points of this meeting are as follows:

- The selection and location of the proposed HSR stations by the study team seem to be good.
- In a previous meeting with Chief Minister on the HSR alignment, he has suggested to have HSR alignment near the coastal line where ever possible because most of the land near the cost is owned by government and thus there will be fewer issues for land acquisition. He however mentioned that there could be two challenges, one the cost of foundation works could be higher considering the nature of soil near coastal areas, and two, because of the saline nature of environment near coastal areas, the damage to rail tracks and other rail infrastructure could be higher due to corrosion.
- A major transit station can be planned to provide good connectivity among the various modes



- of transport (HSR, Metro and existing railway station).
- In Surat, it seems to be no space HSR to enter the city center.
- It would be preferable to have Vadodara HSR station near the existing station.
- Effort should be made to have Ahmedabad HSR station near the existing Ahmedabad Station. One option could be to have underground station.
- It is ok to have HSR station upto 1 to 2 km from existing stations provided there is a re-design of existing stations in such a way that there is good connectivity with HSR station.
- Sabarmati can be an option as there is railway land, but that will not so good from land perspective (city planning).
- It could be easier to have HSR station at Vatva but it is far away from city. In this case, HSR can come underground from Vatva to Ahmedabad and meet the proposed metro station in Ahmedabad because metro is also proposed to come underground to existing Ahmedabad station.
- Study team explained that HSR Technology from several countries will be evaluated and the most appropriate HSR technology for Mumbai- Ahmedabad route shall be proposed.
- Government of Gujarat /GIDB will support the study team; state government has previously funded earlier studies.

### 3) Mumbai Metropolitan Region Development Authority (MMRDA) (21 /01/2014)

Participated Members of Mumbai Metropolitan Region Development Authority are as follows:

Mr. U.P.S.Madan (Metropolitan Comm. and Principal Secretary)	MMRDA
Mr.P.R.K.Murthy (Chief of Transportation)	MMRDA

Main points of this meeting are as follows:

- BKC being the hub of commercial activities in Mumbai, the number of potential users for HSR could be quite high.
- Land at BKC is very expensive as it is a commercial area (land here is sold in square centimeters) whereas HSR will require large areas of land for HSR station at BKC.
- Ideally the entry and exit level should be at surface level but the land at BKC is very expensive. There is a proposal of metro corridor (line 2) which is now proposed to be underground due to availability of land. The design of metro station is ongoing by RITES.

### 4) Western Railway (20/01/2014)

Participated Members of Western Railway are as follows:

Mr. R.K. Tandon (Chief Operation Manager)	WR
Mr. Pranai Prabakar (Chief Transport Planning Manager )	WR
Mr. Santosh. K. Jha (Dy. COM)	

Main points of this meeting are as follows:

- The route alignment seems fine and will not pose a big issue does not look a big issue from environment point of view.
- There is more space in Sabarmati than in Ahmedabad.
- As there is a plan of north-south elevated railway corridor project in Mumbai suburban, HSR would be underground or high-elevated structure.
- The HSR line should be dedicated line as they have different rolling stocks and safety level. Interoperability will defeat the very purpose of HSR.
- Station at Boisar instead of Dananu Road.
- No need for station at Balsad (Bulsar).

#### 5) Central Railway (20/01/2014)

Participated Members of Central Railway are as follows:

Mr. R.D. Tripathi (Chief Operation Manager)	CR
Mr. M.K. Gupta (Chief Administrative Officer, Construction)	CR
Mr. R. Ananth (Dy. General Manager)	CR
Mr. Mukesh Nigam (Divisional Railway Manager)	

Main points of this meeting are as follows:

- They would like to extend HSR till Pune.
- Bandra-Kurla-Complex makes much sense as being central business district.
- Connectivity with conventional suburban railway station should be considered in planning HSR Thane Station. One option is the existing Thane station, but there is no space in Thane. HSR station will be underground. The other options would be connecting with other existing station or new station.
- Mangroves were not serious issue during the construction the railway bridge over Thane creek. Now, even new metro lines are facing problem because of large mangroves on the alignment.
- Data requirement and layout plans of Central Railways will be shared with the study team and they will nominate a person to be the contact point.

#### 6) Mumbai Railway Vikas Corporation (MRVC) (20/01/2014)

Participated Members of Mumbai Railway Vikas Corporation are as follows:

Mr. Rakesh Saksena(Chairman and Managing Director)	MRVC
Mr. Ravi Agarwal (Executive Director, Planning)	MRVC
Mr. Naresh Chandra (Technical)	MRVC

Main points of this meeting are as follows:

- MRVC executed the projects so far identified and also be involved in the planning and the development of Mumbai Suburban Rail system.
- Resettlement and rehabilitation is very critical and land acquisition is again a big challenge in Mumbai.
- Around 15,000 families in phase -1 have been rehabilitated under RNR state government scheme. Environmental Impact assessment is done for all projects executed by MRVC as per World Bank Guidelines. These information would be useful for the study of HSR.

### 4.7.3 Overall Alignment and Station Locations

#### (1) Preparatory Work for Route Planning

The main policy and criteria adopted in the alignment and station study for the HSR route planning is in Figure 4.7-2. The figure below as shown, based on comprehensive evaluation of various perspective of policy, criteria and environmental issues about alignments and station locations, the optimal alignments and station locations should be proposed.

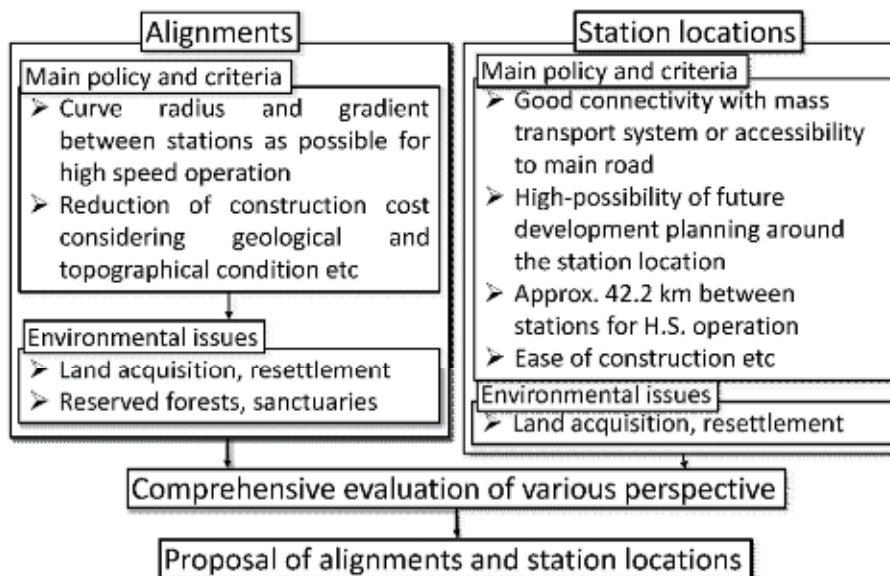

Figure 4.7-2 Consideration of Alignments and Station Locations for HSR

The detail of plane planning and longitudinal planning is described as follows:

#### 1) Plane planning

##### a) Alignment in General

- The stations shall be connected at the shortest distance.
- The stations shall be set up as close to the major city stations of the conventional line as possible.
- The stations shall be located in straight and level sections as much as possible.
- In the case of a curved section, the curve radius shall be as large as possible.
- The longitudinal gradient shall be as gentle as possible.
- Passing through areas that have weak roadbed or that are susceptible to the effects of natural disasters shall be avoided as much as possible.
- Passing through built-up areas (especially near schools, hospitals, temples, etc.) shall be avoided as much as possible (social and environmental considerations for noise, vibration, etc.)
- Considerations shall be taken when selecting station locations in areas earmarked in plans for industrial parks or urban development. The passage of the route shall be discussed with the concerned parties.
- Interference or crossing of important cultural assets shall be avoided.
- Areas (national parks, nature reserves, etc.) where the natural environment or animal welfare may be impacted shall be avoided.
- Bridges shall be planned so that they will cross the big rivers at right angles as much as possible.
- Efforts shall be made so that the high-speed railway will cross the main roads, highways, and conventional lines via overpasses at right angles as much as possible.

- The specified clearance shall be secured when intersecting vertically with main roads, highways, conventional lines, and rivers.
- The breadth of formation level shall be lowered to as much as the vertical alignment allows.
- The alignment shall avoid as much as possible tunnels and special structures that will increase cost. Cutting and embankment shall be used.
- Tunnels shall be as short as possible.
- The gradient of the tunnel sections shall be at least 0.2% for construction and maintenance purposes.
- The alignment shall be planned taking into consideration the route of the planned dedicated freight corridor.

b) Specifications for Curves, etc.

- As a rule, the curve radius shall be  $R = 6000$  m or more. When there is topographical constraint, the minimum curve radius can be reduced up to 400 m in consideration of the speed of the trains (based on implementation standards of the Japan Railway Construction, Transport and Technology Agency).
- The maximum operation speed shall be 320 km/h; however, the alignment shall be planned to allow operation at 350 km/h in the future.
- As a rule, the stations shall be set up in straight-line sections. If it is not possible, the stations shall be set up in simple circular curve sections (minimum curve radius  $R = 1000$  m).

2) Longitudinal Planning

- In consideration of economic efficiency, it is better to avoid tunnel structure as much as possible. The embankments and cuttings are planned as low as possible.
- The gradient shall be less than 25/1000. The gradient near stations shall be less than 3/1000. This is pursuant to the standard for Shinkansen, based on the interpretation standard of the ministerial ordinance specifying the technical standards for railways (Japan National Railway Technology Notification No. 157, March 8, 2002).
- The radius of the vertical curve shall be 25,000 m to create a shape suitable for high-speed operation.
- For a large station that is likely to have high transport demand, a new station will be built adjacent to the existing station if the alignment and structures allow. For the intermediate station that is unlikely to have high demand or if the villages are far apart, a new station will be built near the intersection with access roads on the outskirts rather than building a new station adjacent to the existing one.

(2) Site Survey for Route Planning of HSR

A route plan provides a comprehensive view of the route and is equipped with the technical details for a high-speed railway. It offers information about the life, society, topography, geology, and environment of the region, making it the most important of all high speed railway plans because it will have a direct impact on the demand forecast and the construction cost.

The fundamental approach is to verify the social and living conditions including natural conditions such as topography, geology, climate, hydrology, environmental protection, sanctuaries and townscape, urban land use, condition of the conventional lines, rivers and plans for national roads and highways, and so on.

The study team checked the Mumbai - Ahmedabad section using satellite images of Google Earth in advance, selected several route options for the target areas, and conducted field surveys (by taking cars from Mumbai to Ahmedabad) to find the most appropriate route. During the site survey on the route, following facts are ascertained:

## 1) Major Cities

### Mumbai

Mumbai (also known as Bombay) is the capital city of the Indian state of Maharashtra. It is the most populous city in India, second most populous metropolitan area in India, and the fifth most populous city in the world, with an estimated city population of 18.4 million and metropolitan area population of 20.7 million as of 2011. Along with the neighbouring urban areas, including the cities of Navi Mumbai and Thane, it is one of the most populous urban regions in the world. Some pictures of where the characteristic in this area are shown in the following:



Figure 4.7-3 Bandra Kurla Complex



Figure 4.7-4 Wetland near Bandra Station



Figure 4.7-5 Lokmanya Station Building



Figure 4.7-6 Thane Creek



## Surat

Surat is in the Surat District of Gujarat State. It is the second largest city in the State and has a population of about 4.46 million people. It is a metropolitan city with a population of approx. 4.46 million people. Surat city is developing a ring road at a radius of about 3 km from the city center. The Surat Station of the conventional line is located outside of the ring road. It is slightly away from the city center. Because the conventional line changes direction drastically to the east direction north of the Surat Station to go across the Tapi River, the alignment is not good. The vicinity of the existing Surat Station is located in the alluvial fan of Tapi River. The ground condition is not good. Given the above, we focused our field survey on the planning of the station and the route.

Some pictures of where the characteristic in this area are shown in the following:



Figure 4.7-7 Near Proposed Location of HSR Station (Suburban)



Figure 4.7-8 Near Proposed Suburban Route (NH No. 6)



Figure 4.7-9 Surat Station Building



Figure 4.7-10 Surat Station Plaza



### Vadodara

Vadodara is in the Vadodara District of Gujarat State. It is the third largest city in the State and has a population of about 3.6 million people.

Vadodara City is developing a ring road with the current station almost at its center. Both sides of the conventional line are green areas and open spaces. ROBs are constructed when the conventional line intersects with roads. In view of the above, we conducted our field survey with emphasis on planning the route along the conventional line in order to enter the city center. Mahi River flows through the northwest side of Vadodara city.

Some pictures of where the characteristic in this area are shown in the following:



Figure 4.7-11 Vadodara Station Plaza



Figure 4.7-12 Road Over Bridge above the Existing Railway Line (Under Construction)



Figure 4.7-13 Near Proposed Location of HSR Station (Suburban)



Figure 4.7-14 Mahi River

## Ahmedabad

Ahmedabad is in the Ahmedabad District of Gujarat State. With a population of about 5.5 million people, it is a metropolis with the highest population in the State. The state capital is Gandhinagar which is located at about 20 km northeast of Ahmedabad, with the Sabarmati River between them.

The station of the existing line is almost at the center of Ahmedabad city. There are several ring roads inside the city. Both sides of the conventional line from the south are green areas and open spaces. There are several ROBs at the intersection with roads. In view of the above, we conducted our field survey focusing on planning the route along the conventional line in order to enter the city center.

Some pictures of where the characteristic in this area are shown in the following:



Figure 4.7-15 Ahmedabad Station Building and Plaza



Figure 4.7-16 Ahmedabad Station East Plaza



Figure 4.7-17 Proposed Location of HSR Station (Platform No. 12)



Figure 4.7-18 Near Proposed Suburban Route (Ambli Road)

## 2) Other intermediate cities

When combining the high-speed railway station with the existing station, the high-speed railway can use the facilities of the existing station if their gauges are the same, thus reducing cost.

However, in reality, it is necessary to upgrade the signaling and safety equipment and remodel the entire station structure. In the case of the Japanese Shinkansen, every effort is made to set up joint stations with the major stations. This is due to the high demand to transfer from Shinkansen to the conventional lines and the strong requests from local prefectures and cities, even though the gauges are different. Since the customer bases are the same, the joint station functions as a transportation node.

Although it was decided that this high-speed railway would use standard gauge, regional cities that have become urbanized cannot use effectively their existing station facilities that are designed for broad gauge. It is simple to have a combined station but adding a new high-speed railway station to the existing one will increase the construction cost. In addition, the secession of urban areas will require relocation compensation expenses.

Based on the above, setting up a combined station is not necessarily a requisite. However, rather than setting up a new station completely out of the city limits where access by other modes of public transportation are required, the station locations will be selected in such a way as to ensure ease of access to metro stations and main roads, and adequate station plaza areas.

### Thane

Thane is located in the northern edge of the Thane Creek. It is the center of Thane District in Maharashtra State. According to a 2011 statistical survey, Thane has a population of approx. 1.8 million, making it the biggest satellite city of Mumbai.

Some pictures of where the characteristic in this area are shown in the following:



Figure 4.7-19 Existing Railway Line Near Proposed HSR Station



Figure 4.7-20 Warehouse around Proposed HSR Line

### Virar

Virar is located on the south side of Vaiterna Creek. It is in the Thane District of Maharashtra State. According to a 2011 statistical survey, Virar has a population of approx. 120,000 and is one of Mumbai's satellite cities. The area at about 10 km south of Virar up to Vasai has formed into the Vasai-Virar City Municipal Corporation (VVMC). According to the 2011 statistical survey, it has a population of 1.2 million, making it the fifth largest city in the State of Maharashtra. The Virar station is assumed to go from Virar to Vasai. The elevated track to increase the transport capacity of the conventional line being planned by Western Railway is from Churchgate Station to Virar. The current express train stops at the Vasai Station.

Some pictures of where the characteristic in this area are shown in the following:



Figure 4.7-21 Near Proposed Location of HSR Station



Figure 4.7-22 Virar City

### Boisar

Boisar is an industrial area in Thane district in the Indian state of Maharashtra. It is located some 4.7 kilometers north of Virar, on the Western Railway line of Mumbai Suburban Division Mumbai Suburban Railway.

### Vapi

Vapi is in the Valsad District of Gujarat State. It has a population of about 120,000 people. It is located in the delta area of Damanganga River and is approx. 7 km away from the Arabian Sea. The town is passed by NH8. Daman (west) and Dadra (east), a territory under the direct jurisdiction of the central government, is within 10 km. It will also be included in the service area of the station.

Some pictures of where the characteristic in this area are shown in the following:





Figure 4.7-23 Near Proposed Location of HSR Station



Figure 4.7-24 Near Proposed Route (SH No. 185)

### Bilimora

Bilimora is a city situated on the banks of the river Ambika, in Gandevi taluka and Navsari district of Gujarat state in India. The city comes under the purview of the Surat Metropolitan Region. The city is roughly 70 kilometres (44 miles) south of the city of Surat and is the southernmost point of the Surat Metropolitan Region and the Metropolis of Surat. It is also one of the larger cities in the area. It is linked to Surat by SH 6 and SH 88.

### Bharuch

Bharuch is in the Bharuch District of Gujarat State. The city has a population of about 370,000 people. Narmada River flows through the south side of Bharuch city. Some pictures of where the characteristic in this area are shown in the following:



Figure 4.7-25 Near Proposed Route (SH No. 6)

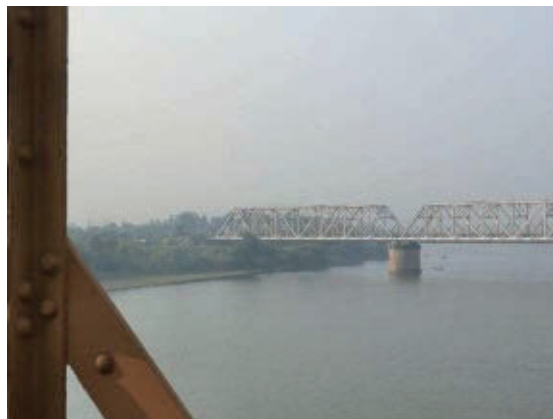

Figure 4.7-26 Narmada River

### Anand/Nadiad

According to the 2011 Census, Anand, the capital of Anand District, has a population of 2,090,276 people. It is the 11th city in Gujarat State. Nadiad, the capital of Kheda District, has a population of 2,298,934 people. It is the ninth city in Gujarat State. Both cities are similar in size. There is concern about possible resentment if the station is set up in either of the cities. For this reason, the new Anand/Nadiad station is planned for the middle of the two cities. This will create a balance between stations in the Ahmedabad–Vadodara section. It is the method used for the

Tsubame-Sanjo Station of the Joetsu Shinkansen line in Japan.  
Some pictures of where the characteristic in this area are shown in the following:



Figure 4.7-27 Anand Station Building and Plaza



Figure 4.7-28 Near Proposed Location of HSR Station



Figure 4.7-29 Nadiad Station Building and Plaza

### Sabarmati

Sabarmati is located on the bank of Sabarmati River. Sabarmati is developed and rich area of the western Ahmedabad. Main areas of Sabarmati are Ramnagar, Dharmnagar, Javaharchowk, Kabirchowk, Ranip, Kaligam, Motera, Chandkheda and D-cabin. Sabarmati is very religious place to live in. There are also many communities living in Sabarmati.



### (3) Comparison of alternative alignment plans

#### 1) The proposed alternative alignments for entry to Mumbai

There are 3 alternatives considered for route planning named as “PLAN A”, “PLAN B” and “PLAN C”. PLAN A is indicated by a red line, PLAN B is indicated by a blue line and PLAN C is indicated by a yellow line. Detail consideration of each alternative is described as follows:

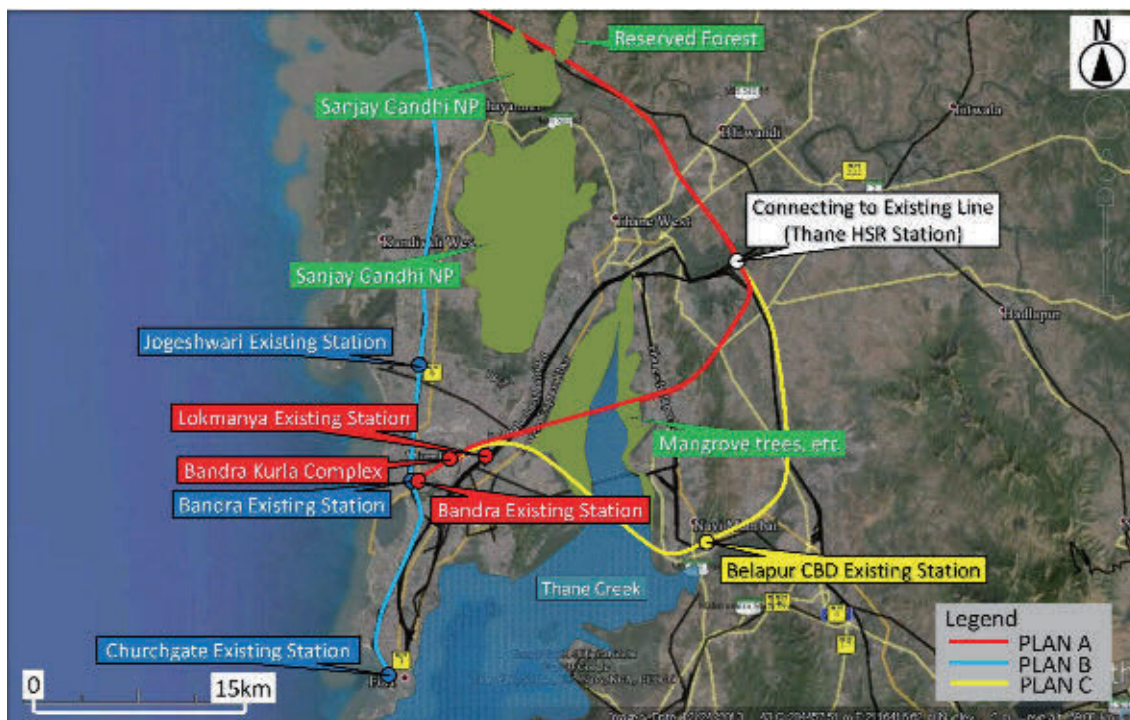

Source: Google earth, Study team

Figure 4.7-30 The Proposed NP Alternative Alignments for Entry to Mumbai

#### Plan A

The route will go towards the northeast direction, cross the Thane Creek and Thane area from Bandra Existing Station or Bandra Kurla Complex or Lokmanya Station.

Main points of planning are as follow:

- In the point of view of passenger demand, the route can cover both CBD of Mumbai and Navi Mumbai area.
- The route has a possibility of future extension to Pune.
- Because both sides of Thane Creek is covered with mangrove trees, comparing the construction difficulties of tunnels and bridges is necessary but a thorough review, including the environmental aspect, is essential.

#### Plan B

The route will go towards the north direction along west coastal existing railway line from Chuchgate Existing Station or Bandra Existing Station or Jogeshwari Station.

Main points of planning are as follows:

- The route length is the shortest among three route plans if Bandra is set as starting station, however it can't cover Navi Mumbai area and doesn't have a possibility of future extension to Pune.
- It is necessary to avoid conflict with the existing improvement plans of WR (Western

Railway) and CR (Central Railway) to increase the transport capacity of the conventional lines and to elevate tracks.

- Central Railway is also planning elevated tracks for one route that originates from Chhatrapati Shivaji Terminus (CST, World Heritage Site), goes from Kurla, crosses the Thane Creek to Panvel, and goes further south and another route that goes to Kalyan via Kurla-Thane. Both are elevation plans for the conventional lines.

### Plan C

The route will go towards the east and southeast direction, cross the Thane Creek and Thane area from Bandra Existing Station or Bandra Kurla Complex or Lokmanya Station through Belapur CBD Existing Station, which is Central Business District of Navi Mumbai.

Main points of planning are as follows:

- In the point of view of passenger demand, the route can cover both CBD of Mumbai and Navi Mumbai area.
- The route has a possibility of future extension to Pune.
- Too close the distance between the stations.
- Additional cost due to underground station and operation cost are necessary.

**Table 4.7-2 Comparison of Alignment (Mumbai Area)**

Item		PLAN A	PLAN B	PLAN C
Main policy and criteria	Outline of alignments	Through Thane area and Thane creek	Along west coast existing line	Through Thane area, Navi Mumbai area and Thane creek
	Proposed station	New Thane, Bandra Kurla Complex, (or Lokmanya, or Bandra)	Bandra, (or Jogeshwari, or Churchgate)	Belapur CBD Railway Station (Underground), New Thane, Bandra Kurla Complex
	Distance / Time (from Virar)	64.0km / 25min (to BKC from Proposed Virar Station)	45.5km / 14min (to Bandra from Existing Virar Station)	80.7km / 32min (to BKC from Proposed Virar Station)
	Passenger demand	Covering both CBD and Navi Mumbai area	Not covering Navi Mumbai area	Covering both CBD and Navi Mumbai area
	Possibility of future extension to Pune	Possibility of future extension to Pune	No possibility of future extension to Pune	Possibility of future extension to Pune
Environment issues		By tunneling , environment issues would be avoided	Resettlement would be needed	By tunneling , environment issues would be avoided
Cost(Construction)		1.00 ※1	0.85 ※2	1.54 ※3
Total evaluation		✓✓ 1) Large covering area of H.S.R	✓ 1) Relatively small covering area of H.S.R	✓ 1) Too close the distance between the stations. 2) Additional cost due to underground station and operation cost.

Note)

※1 Index of construction cost (only civil from Virar)(not including land cost, removal of hindrance, electric equipment)

※2, 3 Comparative Index

CBD: Central Business District

Source: Study team

2) More detailed study in the case of Churchgate of Plan B route for entry to Mumbai in ITR-2

In the stage of ITR-2, more detailed study was conducted regarding Plan B in Mumbai area as shown in Table 4.7-3. The route will go towards the north direction along west coastal existing railway line from Churchgate Existing Station.

Plan A

Main points of planning has already described as above.

Plan B

Main points of more detailed study are as follows:

- The distance is shortest among three plans, however, the construction cost would be approx. 1.14 times higher than that of Plan A. Additional cost would be needed due to underground station and operation cost.
- Metro line 3 is planned until near the southern toe of the peninsula in the future, and if the HSR route extends to Churchgate, there would be a possibility that the split of passengers occurs.

Plan C

Main points of planning has already described as above.

Table 4.7-3 Comparison of Alignment (Mumbai Area)

Item		PLAN A	PLAN B	PLAN C
Main policy and criteria	Outline of alignments	Through Thane area and Thane creek	Along west coast existing line	Through Thane area, Navi Mumbai area and Thane creek
	Proposed station	New Thane, Bandra Kuria Complex, (or Lokmanya, or Bandra)	Churchgate, (or Bandra, Jogeshwari)	Belapur CBD Railway Station (Underground), New Thane, Bandra Kuria Complex
	Distance / Time (from Virar)	64.0km / 25min (to BKC from Proposed Virar Station)	61.5km / 25min (to Churchgate from Existing Virar Station)	80.7km / 32min (to BKC from Proposed Virar Station)
	Passenger demand	Covering both CBD and Navi Mumbai area	Not covering Navi Mumbai area	Covering both CBD and Navi Mumbai area
	Possibility of future extension to Pune	Possibility of future extension to Pune	No possibility of future extension to Pune	Possibility of future extension to Pune
Environment issues		By tunneling, environment issues would be avoided	Resettlement would be needed	By tunneling, environment issues would be avoided
Cost(Construction)		1.00 ※1	1.14※2	1.54 ※3
Total evaluation		✓✓ 1) Large covering area of H.S.R	✓ 1) Additional cost due to underground station and operation cost.	✓ 1) Very close distance between the stations. 2) Additional cost due to underground station and operation cost.

Note)

※1 Index of construction cost (only civil from Virar)(not including land cost, removal of hindrance, electric equipment)

※2, 3 Comparative Index

CBD: Central Business District

Source: Study team

3) More detailed study in the case of Bandra of Plan B route for entry to Mumbai in ITR-2  
In the stage of ITR-2, more detailed study was conducted regarding Plan B in Mumbai area as shown in Figure 4.7-31. The route will go towards the north direction along west coastal existing railway line from Bandra Existing Station.

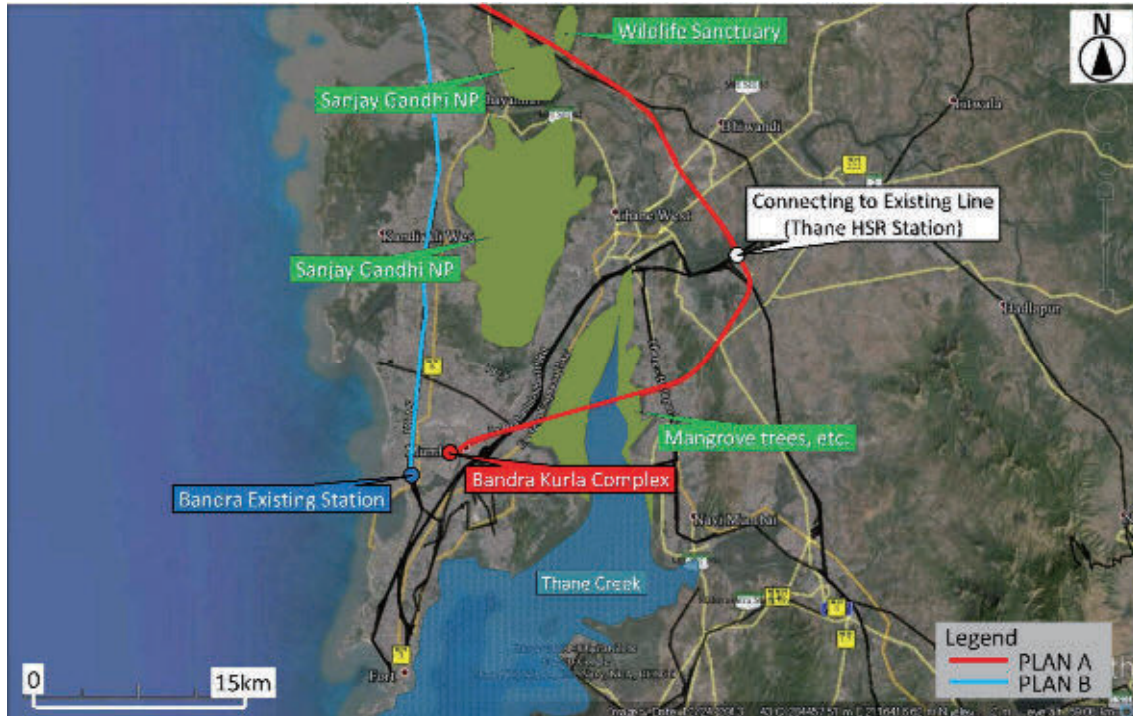

Source: Google earth, Study team

Figure 4.7-31 More Detailed Study Regarding Plan A and Plan B for Entry to Mumbai

Table 4.7-4 shows the detailed comparison of Plan A and Plan B route in Mumbai area.

#### Plan A

Main points of planning has already described as above.

#### Plan B

Main points of more detailed study are as follows:

- High viaduct for passing over many ROBs would be needed.
- There are some constraints regarding plane and profile for high speed operation due to narrow land of Western railway.
- Tunnel section would be needed on parts of urban area due to narrow land of Western railway.
- Land acquisition and resettlement would be needed so much due to passing through densely populated areas.
- There are two necessary countermeasures on environmental issues, one is for noise and vibration due to passing through residential areas and another is for safety approx. 25 km in total during construction stage due to passing along Western railway line.
- Index of construction cost has changed from 0.85 to 0.93 including construction costs for adjacent operational line and buildings compared with Plan A.



Table 4.7-4 Detailed Comparison of Alignment (Plan A and Plan B in Mumbai Area)

Item		PLAN A	PLAN B
Main policy and criteria	Outline of alignments	<ul style="list-style-type: none"> <li>Through Thane area and Thane creek</li> <li>Tunnel section was adopted on main part of urban area and Thane Creek</li> </ul>	<ul style="list-style-type: none"> <li>Along west coast existing line</li> <li>Passing through densely populated areas</li> <li>High viaduct for passing over ROB</li> <li>Constraint (plane and profile) of high speed operation due to narrow land of Western Railway</li> <li>Tunnel section would be needed on parts of urban area</li> </ul>
	Proposed station	3 stations (Bandra Kurla Complex, New Thane and Virar)	2 stations (Bandra and Virar)
	Distance / Time (from Virar)	64.8km / 25min (to BKC from Proposed Virar Station)	45.5km / 14min (to Bandra from Existing Virar Station)
	Passenger demand	Covering both CBD and Navi Mumbai area	Not covering Navi Mumbai area
	Possibility of future extension to Pune	Possibility of future extension to Pune	No possibility of future extension to Pune
Land acquisition and Resettlement	By tunneling , land acquisition and resettlement would be easy	Land acquisition and resettlement would be needed so much due to passing through densely populated areas	
Environment issues	By tunneling , environment issues would be avoided	<ul style="list-style-type: none"> <li>Countermeasures for noise and vibration would be needed due to passing through residential areas</li> <li>Countermeasures for safety would be needed approx. 25km in total during construction stage due to passing along Western Railway line</li> </ul>	
Cost(Construction)	1.00 ※1	0.93※2	
Total evaluation	✓	✓	

Note)

※1 Index of construction cost (only civil from Virar)(not including land cost, removal of hindrance, electric equipment)

※2 Comparative Index

CBD: Central Business District

Source: Study team

#### 4) Through Thane Creek (Tunnel or Viaduct case)

There are 2 alternatives considered for route planning through Thane Creek. Detail consideration of each alternative is described as follows:

Figure 4.7-32 and Figure 4.7-33 each show the route plan and longitudinal concept of the tunnel case and viaduct case from BKC to Navi Mumbai area through Thane Creek.

Main points of planning are as follows:

- Environmental issues can be avoided in the case of tunnel cased, that is, the tunnel can provide protection of mangrove flourishes on both side of Thane Creek.
- Land acquisition of tunnel is easier than this of viaduct and bridge.
- Construction cost of tunnel is higher than this of viaduct and bridge.
- It is important to conduct geological survey and study of the surrounding environment in detail in order to determine the type of tunnel.

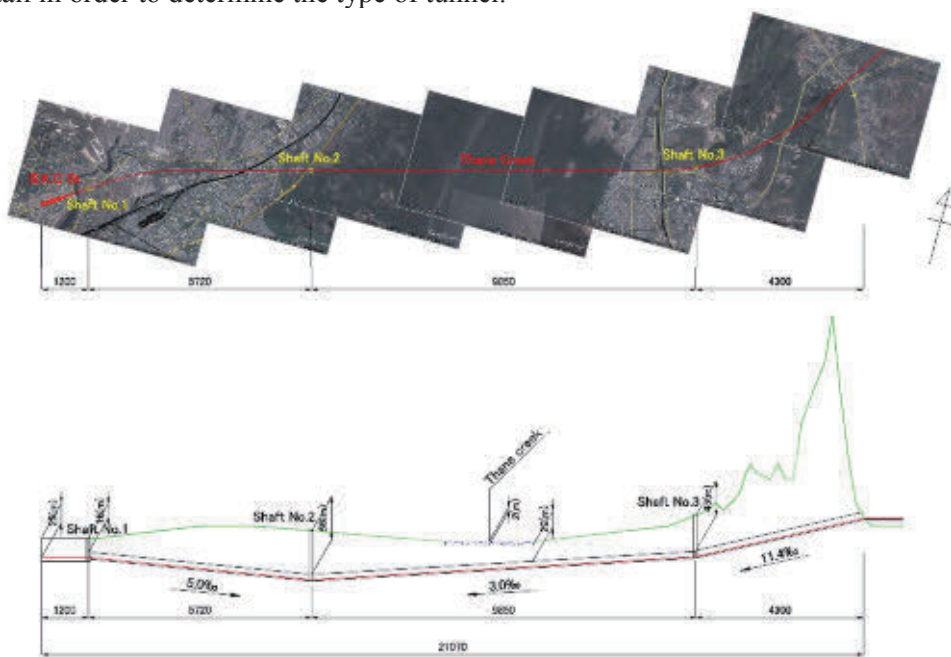

Source: Google earth, Study team

Figure 4.7-32 Alternative Plan Crossing Thane Creek (Tunnel Case)



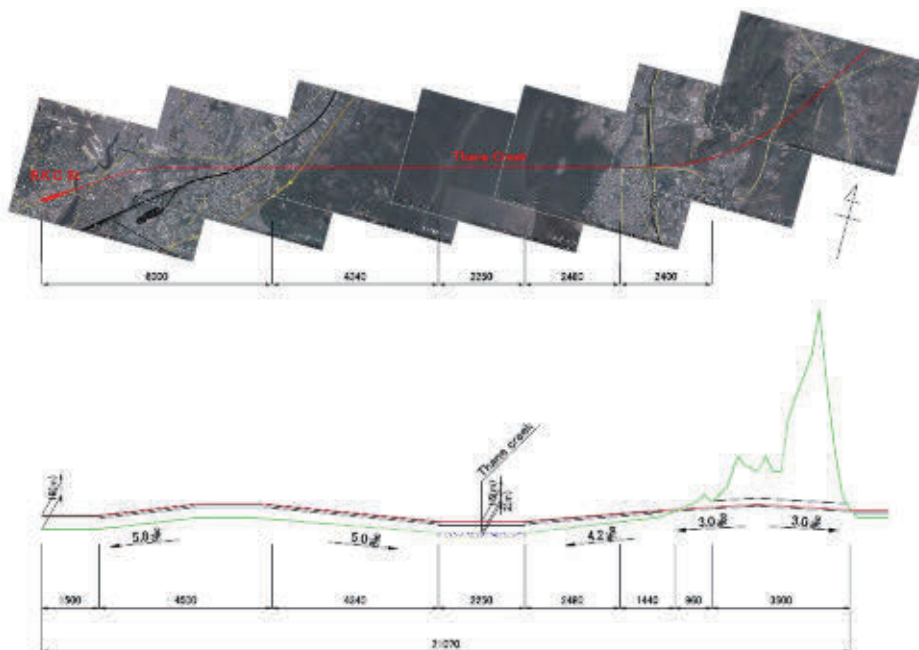

Source: Google earth, Study team

Figure 4.7-33 Alternative Plan Crossing Thane Creek (Viaduct Case)

#### 5) The proposed alternative alignments for entry to Ahmedabad

There are 2 alternatives considered for route planning named as “PLAN A” and “PLAN B”. PLAN A is indicated by a red line and PLAN B is indicated by a blue line. Detail consideration of each alternative is described as follows:

##### Plan A

The route will go towards the northwest direction, along the existing railway line to Vatwa railway yard or Kankaria freight yard or Ahmedabad existing Station or Asarwa railway yard or Sabarmati existing station.

Main points of planning are as follows:

- In the point of view of passenger demand, the route can cover CBD.
- The route length is approx. 10km shorter than Plan B route length.

##### Plan B

The route will go towards suburb of west side Ahmedabad.

Main points of planning are as follows:

- The route can't cover CBD, but would cover a new industrial area.

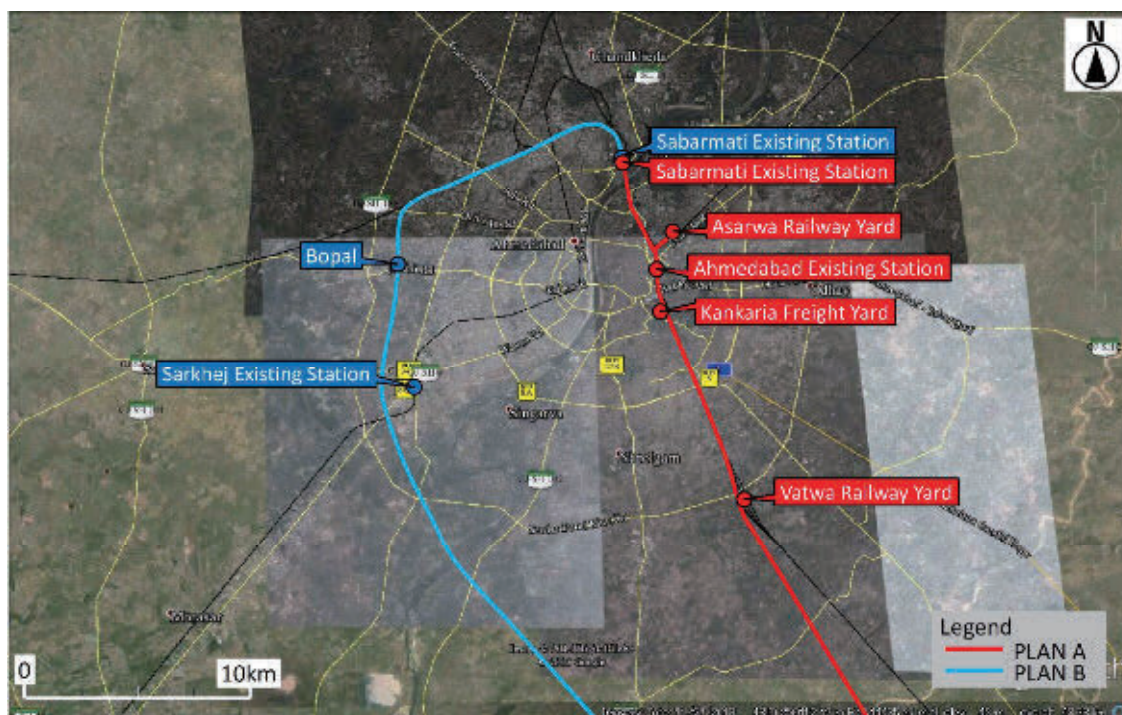

Source: Google earth, Study team

Figure 4.7-34 The Proposed Alternative Alignments for Entry to Ahmedabad

Table 4.7-5 Comparison of Alignments (Ahmedabad Area)

	PLAN A	PLAN B
Outline of alignments	Along existing Railway line to city center	Suburb of West side Ahmedabad
Proposed station	Ahmedabad (or Sabarmati, or Vatwa, or Kankaria, or Asarwa)	Bopal (or Sarkhej, or Sabarmati)
Distance / time (from Anand/Nadiad)	54.8km / 18min (to Ahmedabad from Proposed Anand/Nadiad Station)	65.1km / 19min (to Bopal from Proposed Anand/Nadiad Station)
Passenger demand	<ul style="list-style-type: none"> <li>Covering CBD</li> </ul>	<ul style="list-style-type: none"> <li>Not covering CBD</li> <li>New industrial area would be covered</li> </ul>
Environment issues	Land acquisition and resettlement would be needed	Resettlement would be less than plan A
Total evaluation	✓✓	✓

Source: Study team

#### 6) Approach plan to Ahmedabad and Sabarmati along the existing railway line

As for the case of setting HSR station near existing Ahmedabad station and Sabarmati station along the railway line, the more detailed study are conducted as shown in Figure 4.7-35.

Main points of planning are as follows:

- There are 7 ROBs from Sardar Patel Ring Road to Ahmedabad existing station and 5 ROBs

from Ahmedabad existing station to Sabarmati existing station above the existing railway line, therefore, the route would be necessary to crossover these ROBs at over 18 meters height.

- Concerning extending to Sabarmati area, it is recommended that the construction between Ahmedabad existing station and Sabarmati should be carried out in the future according to passenger demand in the view point of convenience improvement.
- At the section owned by Western Railway between storage track of south side of Ahmedabad existing station and north side of Vatwa existing station, 3<sup>rd</sup> railway line for passengers has already sanctioned, 4<sup>th</sup> railway line for passengers has being planned.

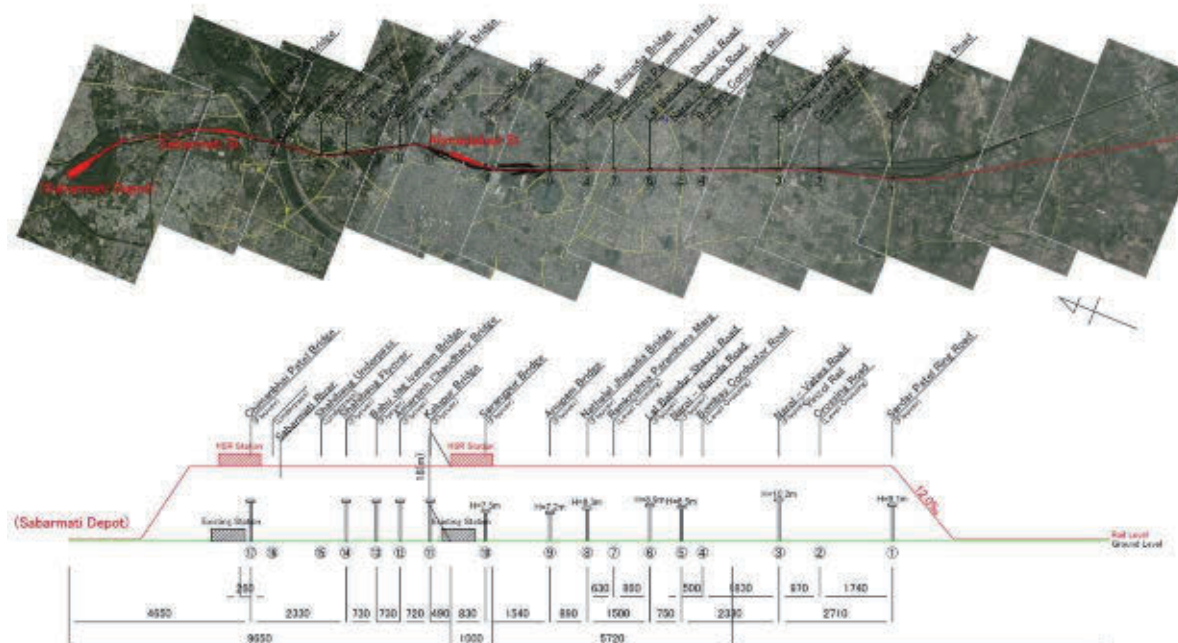

Source: Google earth, Study team

Figure 4.7-35 Approach Plan to Ahmedabad (Draft)

7) More detailed study of Approach plan to Ahmedabad area including extension to Sabarmati

There are 2 alternatives considered for route planning named as “PLAN A” and “PLAN B”. PLAN A is indicated by a red line and PLAN B is indicated by a blue line. Detail consideration of each alternative is described as follows:

Plan A

- It has been recommended Ahmedabad station and Sabarmati station in consideration of the construction cost compared with Plan B.
- The Cost of setting both Ahmedabad HSR station and Sabarmati station including route extension roughly is estimated 1.3 times higher than one of setting Ahmedabad HSR station only.
- The Land acquisition and the construction near operation line is not easier.
- Besides Ahmedabad HSR station, Sabarmati HSR station is recommended considering access to the station.



Plan B

- The Land acquisition and the construction is easier, however, the route length and operating time is extended, in addition, the cost of Plan B is roughly estimated approx. 1.3 - 1.4 times higher than one of Plan A. Therefore, it is not recommended.

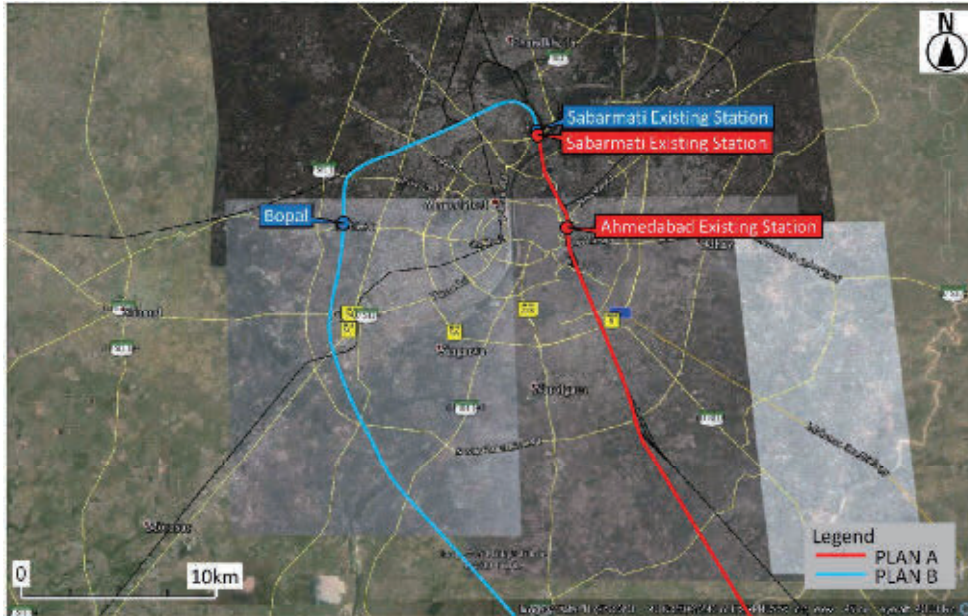

Source: Google earth, Study team

Figure 4.7-36 The Proposed Alternative Alignments for Entry to Ahmedabad (Along the Railway Line or through the West-suburban)

Table 4.7-6 Comparison of Alignments and Station Locations (Plan A)

Main policy and criteria	Ahmedabad	Ahmedabad+ Sabarmati
Passenger demand	Covering CBD area	Covering CBD area and Sabarmati
Distance/Time(from Mumbai)	500.6km / 2 HRS 00 MIN	506.4km(500.6+5.8) / 2 HRS 08 MIN
Connectivity with Mass Transport system	Good connectivity with existing railway and Metro	Good connectivity with two existing railway and Metro
Situation around the proposed HSR station	• Already built-up area • Traffic congestion	• Already built-up area • Good road access
Position of station	Elevated	Elevated
Land acquisition	Land of Indian railway	Huge land of Indian railway
Access to proposed HSR station	Elevated	Long elevated line over the river
Cost(Construction and O&M)	1.00 ※1	1.32 ※2 Additional 50~60 station staff will be needed
Total evaluation	✓✓	✓✓

Note)

※1 Index of construction cost (only civil from Anand/Nadiad)(not including land cost, removal of hindrance, electric equipment)

※2 Comparative Index

CBD: Central Business District

Source: Study team

Table 4.7-7 Comparison of Alignments and Station Locations (Plan B)

Main policy and criteria	Sabarmati	Sabarmati + Bopal
Passenger demand	CBD area	CBD area
Distance/Time(from Mumbai)	527.7km / 2 HRS 07 MIN	527.7km(513.9+13.8) / 2 HRS 14 MIN
Connectivity with Mass Transport system	Good connectivity with existing railway and metro	Good connectivity with existing railway and metro
Situation around the proposed HSR station	• Already built-up area • Good road access	• New development area + Already built-up area • Good road access
Position of station	Elevated	Elevated
Land acquisition	Huge land of Indian railway	Huge land of Indian railway , Green Field
Access to proposed HSR station	Long elevated line	Long elevated line
Cost(Construction)	1.32 ※3	1.42※4 Additional about 30 station staffs will be needed
Total evaluation	✓	✓

Note) 3, 4 Comparative index

Source: Study team

#### 8) Study of station plan for setting the HSR station to Sabarmati existing station from south side

As for the case of setting the HSR station to Sabarmati existing station from south side, the more detailed study are conducted as shown in Figure 4.7-37.

Main points of planning are as follows:

- It is planned that Sabarmati HSR station is 3 layer structures, and 1st floor is for concourse 2nd floor is for track.
- It is planned that the proposed HSR station would connected to Sabarmati railway station (elevated) and AEC railway station (elevated) of North - South Metro Corridor by proposed pedestrian walkway at elevated.
- It is planned that east and west existing station plaza would be connected with three pedestrian walkways (elevated).
- According to Draft Development Plan-2021 (2<sup>nd</sup> revised), CBD is located a little far from existing railway station. It is recommended that the east side of east side existing railway is also planned as CBD.

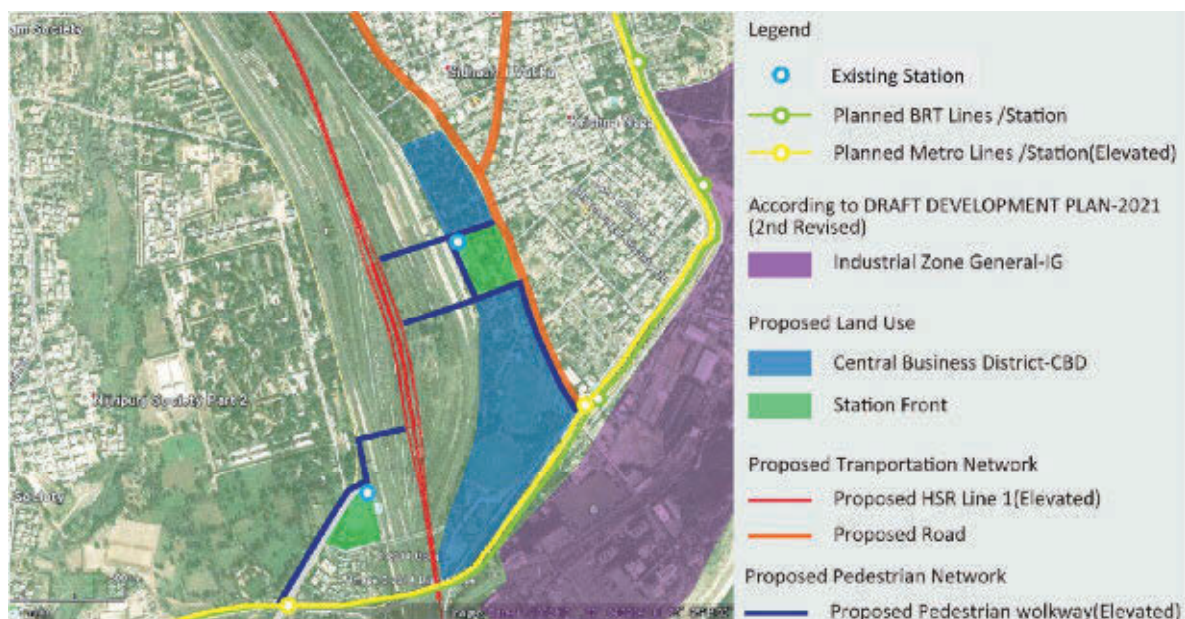

Source: Google earth, Study team

Figure 4.7-37 Station Plan of Sabarmati (Draft)

#### 9) The proposed alternative alignments for entry to Surat

There are 2 alternatives considered for route planning named as “PLAN A” and “PLAN B”. PLAN A is indicated by a red line and PLAN B is indicated by a blue line. Detail consideration of each alternative is described as follows:

##### Plan A

The route will go towards suburban of east side center of Surat.

Main points of planning are as follows:

- The route will go near the Ring Road planned by Surat Urban Development Authority.

##### Plan B

The route goes along the existing railway line after and before Surat existing railway station.

Main points of planning are as follows:

- The proposed HSR Station would be juxtaposed to the Surat existing railway station.





Source: Google earth, Study team

Figure 4.7-38 Route Alternatives of Surat Area

10) Approach plan before and after Surat existing station

Main points of planning are as follows:

- There are 3 ROBs crossing the existing railway line, therefore, the route would be necessary to crossover these ROBs at over 18 m height.

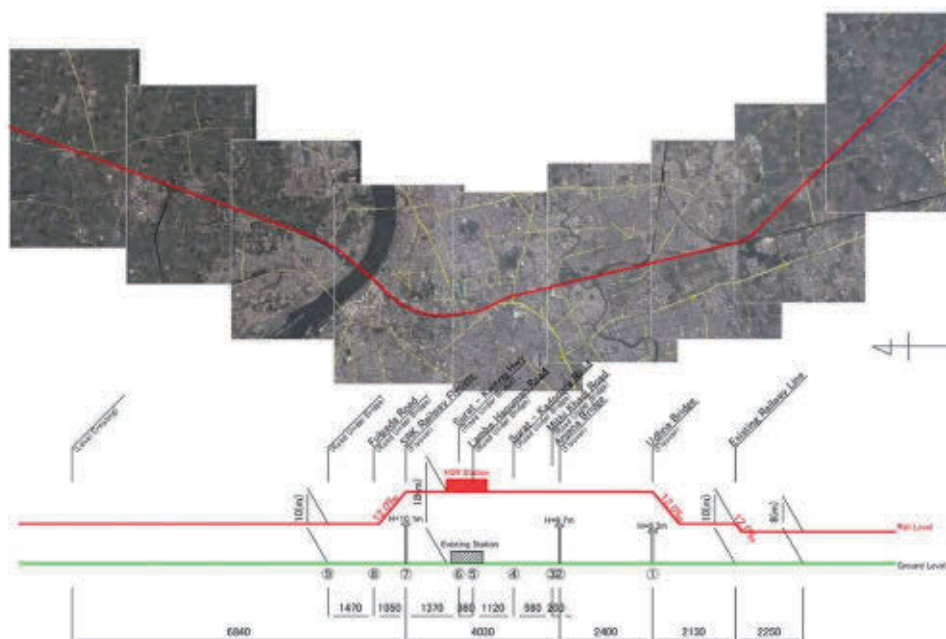

Note

- 1) Ground Level is assumed to be horizontal.
- 2) H of Flyover shows the distance between existing rail level and pavement of the flyover on the point.

Source: Google earth, Study team

Figure 4.7-39 Approach Plan before and after Surat (Viaduct Case)

## 11) The proposed alternative alignments for entry to Vadodara

There are 2 alternatives considered for route planning named as “PLAN A” and “PLAN B”. PLAN A is indicated by a red line and PLAN B is indicated by a blue line. Detail consideration of each alternative is described as follows:

### Plan A

The route goes along the existing railway line after and before Vadodara existing railway station. Main points of planning are as follows:

- The proposed HSR Station would be juxtaposed to the Vadodara existing railway station.
- It is expected that passenger demand increase for connectivity with existing railway station.

### Plan B

The route will go towards suburban of west side center of Vadodara.

Main points of planning are as follows:

- According to Sanctioned second revised development plan proposed land use 2031D, the proposed station and route are located at Residential area.
- Cost of this plan would be not higher than Plan A.



Source: Google earth, Study team

Figure 4.7-40 Route Alternatives of Vadodara Area

## 12) Approach plan before and after Vadodara existing station

Main points of planning are as follows:

- There are 6 ROBs crossing the existing railway line, therefore, the route would be necessary to crossover these ROBs at over 18 m height.
- There is the storage yard on the north side of existing railway station. The HSR route must cross over or go along the storage yard.

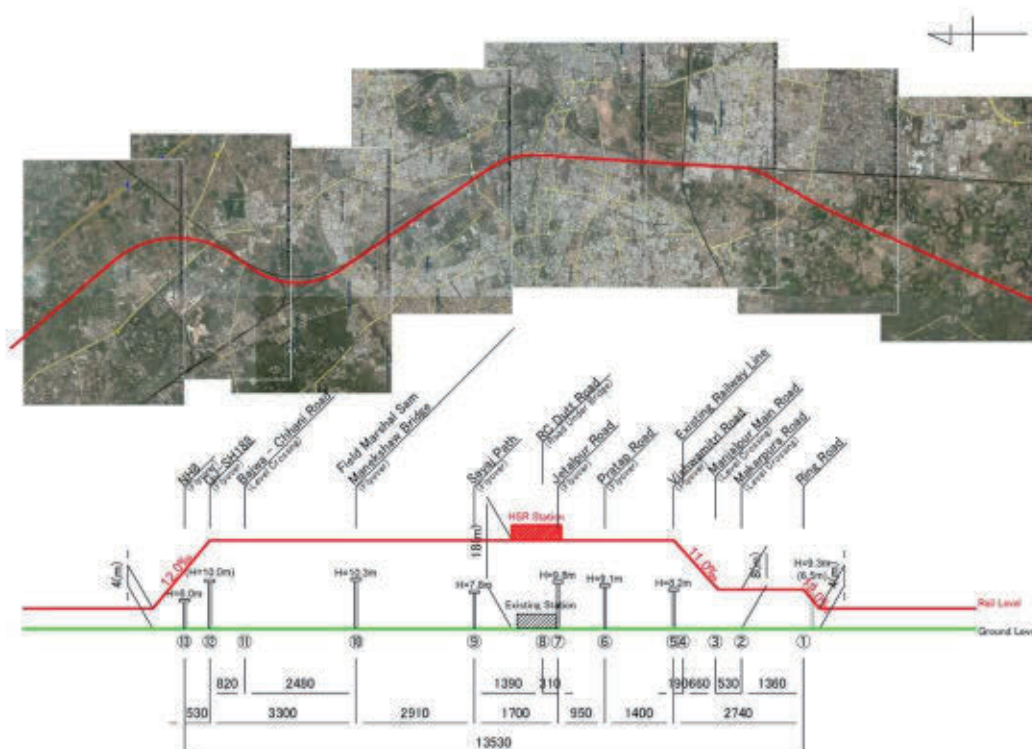

Note

- 1) Ground Level is assumed to be horizontal.
- 2) H of Flyover shows the distance between existing rail level and pavement of the flyover on the point.

Source: Google earth, study team

Figure 4.7-41 Approach Plan before and after Vadodara (Viaduct Case)

#### (4) Comparison of alternative station locations

##### 1) Mumbai Area

There are 6 alternatives considered for station locations of Mumbai area.

##### Plan A

Alternative proposed stations are planned as underground station.

##### Bandra Kurla Complex

Main points of planning are as follows:

- The area is new development area and covering CBD area.
- The location has good connectivity with planned Metro Station and good road access.
- The Vacant space of Bandra-Kurla Complex for planned HSR station is owned by Metropolitan Region Development Authority (MMRDA)

### Lokmanya

Main points of planning are as follows:

- The location is a little far from CBD area.
- The location has good connectivity with existing railway station.
- The area is already build-up area, therefore there is traffic congestion.
- The location of proposed HSR Station is owned by Indian railway.

### Bandra

Main points of planning are follows:

- The location is a little far from CBD area.
- The location has good connectivity with existing railway station and planned metro station.
- The area is already build-up area, therefore there is traffic congestion.
- The location of proposed HSR Station is partially owned by Indian railway.

Table 4.7-8 Comparison of Station Location (Mumbai Area – Plan A)

	Bandra Kurla Complex	Lokmanya	Bandra
Passenger demand	Covering CBD area	A little far from CBD area	A little far from CBD area
Connectivity with Mass Transport system	Good connectivity with Metro	Good connectivity with existing railway	Good connectivity with existing railway and Metro
Situation around the proposed HSR station	<ul style="list-style-type: none"> <li>▪ New development area</li> <li>▪ Good road access</li> </ul>	<ul style="list-style-type: none"> <li>▪ Already built-up area</li> <li>▪ Traffic congestion</li> </ul>	<ul style="list-style-type: none"> <li>▪ Already built-up area</li> <li>▪ Traffic congestion</li> </ul>
Position of station	Underground	Underground	Underground
Land acquisition	Land of MMRDA, or under road space	Land of Indian railway	Partial land of Indian railway
Access to proposed HSR station	Underground	Underground	Underground
Total evaluation	✓✓	✓	✓

Source: Study team

### Plan B

Bandra proposed station and Jogeshwari proposed station are planned as elevated station, and Churchgate proposed station is planned as underground station.

### Bandra

Main points of planning are as follows:

- The location is a little far from CBD area.
- The location has good connectivity with existing railway station and planned metro station.
- The area is already build-up area, therefore there is traffic congestion.
- The location of proposed HSR Station is partially owned by Indian railway.



### Jogeshwari

Main points of planning are as follows:

- The location is a little far from CBD area.
- The location has good connectivity with existing railway station.
- The area is already build-up area, therefore there is traffic congestion.
- The location of proposed HSR Station is owned by Indian railway.

### Chuchgate

Main points of planning are as follows:

- The location covers CBD area and tourist area.
- The location has good connectivity with existing railway station and planned metro station.
- The area is already build-up area, therefore there is traffic congestion.
- The proposed HSR Station is located at underground of Park.

Table 4.7-9 Comparison of Station Location (Mumbai Area – Plan B)

	Bandra	Jogeshwari	Churchgate
Passenger demand	A little far from CBD area	A little far from CBD area	Covering CBD and tourist area
Connectivity with Mass Transport system	Good connectivity with existing railway and Metro	Good connectivity with existing railway	Good connectivity with existing railway and Metro
Situation around the proposed HSR station	<ul style="list-style-type: none"> <li>▪ Already built-up area</li> <li>▪ Traffic congestion</li> </ul>	<ul style="list-style-type: none"> <li>▪ Already built-up area</li> <li>▪ Traffic congestion</li> </ul>	<ul style="list-style-type: none"> <li>▪ Already built-up area</li> <li>▪ Traffic congestion</li> </ul>
Position of station	Elevated	Elevated	Underground
Land acquisition	Partial land of Indian railway	Land of Indian railway	Park (Cross Maidan)
Access to proposed HSR station	Elevated (or underground)	Elevated	Underground (Long tunnel)
Total evaluation	✓	✓	×

Source: Study team

#### a) Study of station plan in the case of Bandra Kurla Complex

As for the case of setting HSR station to Bandra Kurla Complex, the more detailed study was conducted as shown in Figure 4.7-42, Figure 4.7-43 and Figure 4.7-44.

Main points of planning are as follows:

- HSR station would be connected to planning Bharat Nagar station and planning Complex Road station at underground.
- HSR station can also be connected to Metro Line3-Bandra station by underground passage.
- It is recommended that Section A is more preferable than Section B in the view point of the difference with construction period.
- Even if there is a plan to develop over this place, the construction such as high-rise buildings would be possible as shown in Figure 4.7-44.

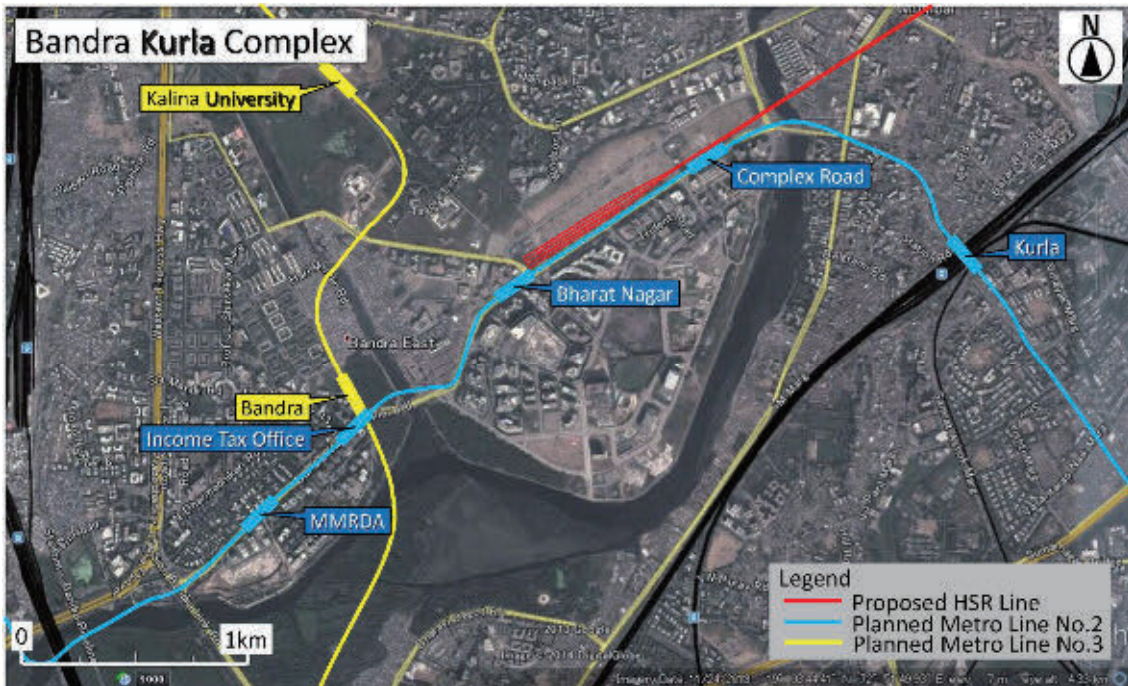

Source: Google earth, study team

Figure 4.7-42 Station Plan of Bandra Kurla Complex

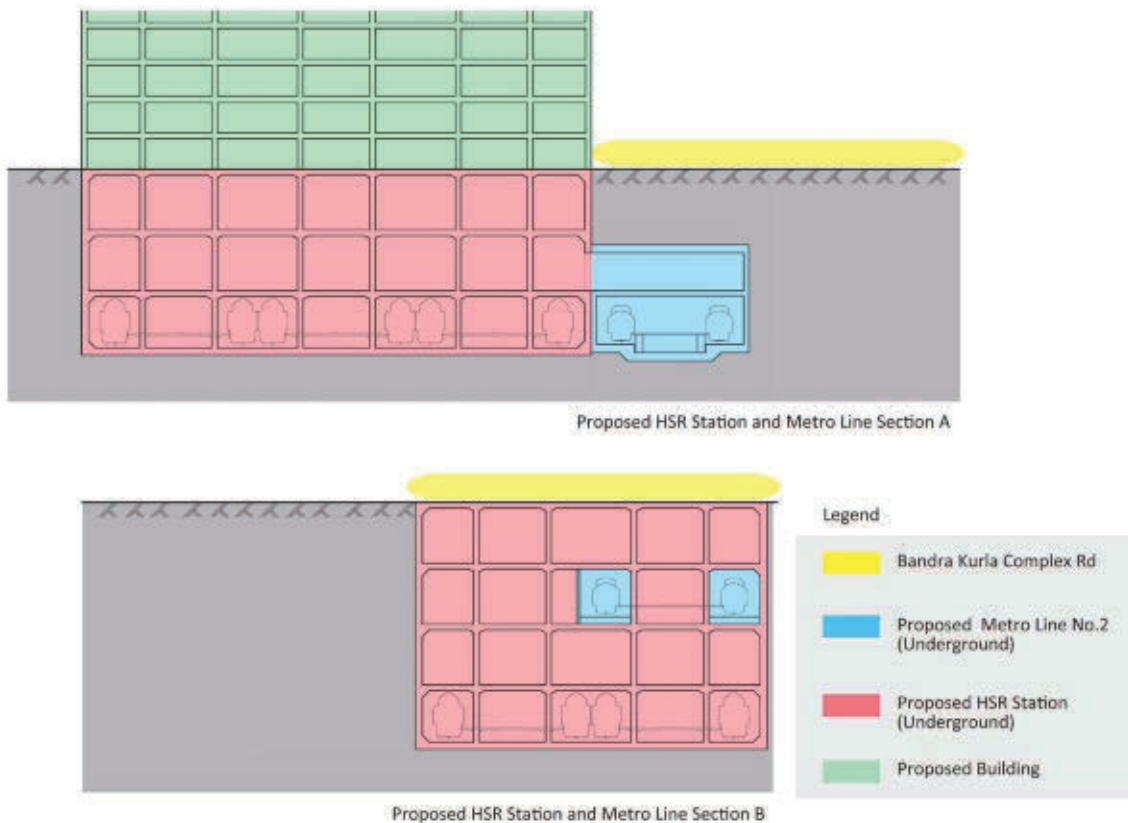

Source: Study team

Figure 4.7-43 Station Section of Bandra Kurla Complex



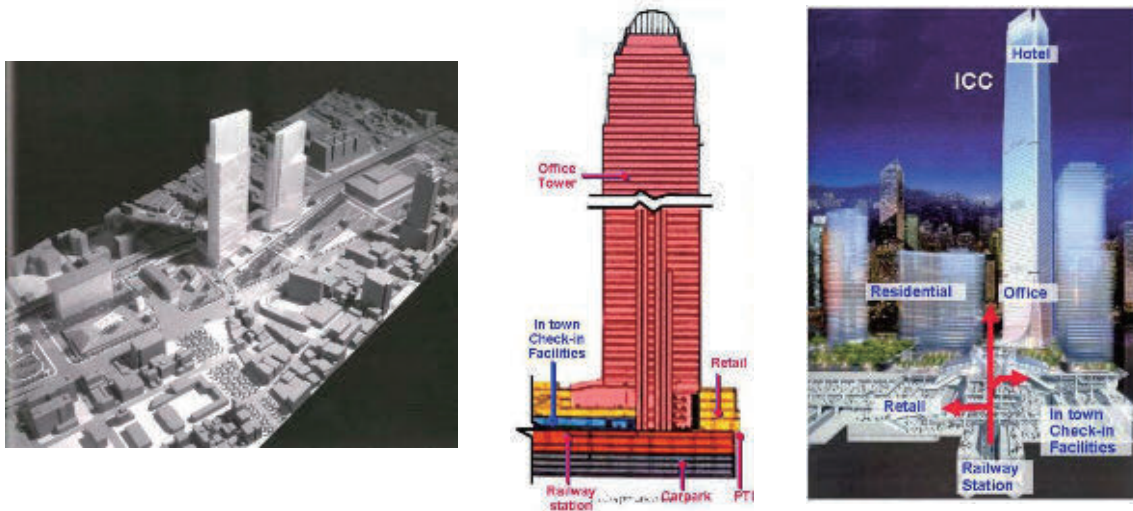

Source: Study team

Figure 4.7-44 Image of High Rise Buildings on BKC Station

b) More detailed study of station plan for Bandra Kurla Complex, Bandra and Dadar in ITR-2

In the stage of ITR-2, more detailed study of station plan was conducted for Bandra Kurla Complex, Bandra and Dadar. Figure 4.7-45 shows the locations and the routes. Plan A indicates the route that location of terminal station is near Bandra existing station and the extended length from Bandra Kurla Complex is approx. 2.7 km at underground. On the other hand, Plan B indicates the route that location of terminal station is between Dadar western railway station and Dadar central railway station and the extended length compared with main route proposed by study team is approx. 5.6 km at underground.



Source: Google earth, study team

Figure 4.7-45 Locations and Routes of Terminal Station Proposed in Mumbai Area

### Plan A

As for the case of setting HSR station near Bandra existing railway station, the more detailed study was conducted.

Main points of planning are as follows:

- Proposed Bandra HSR station is located near existing Bandra station on northwest side at underground.
- Approx. 250 m of Bandra HSR station belongs to swampy land owned by Indian railway and approx. 470 m passes under buildings, residential area and NH No.8.
- In the case of cross section B-B, open cut with underpinning method would be needed.
- Index of construction cost (station only) compared with BKC HSR station is 1.45.
- It takes 4 year and 9 months to construct this station only.



Source: Google earth, study team

Figure 4.7-46 Location of Plan A (Southeast of Bandra Existing Railway Station)



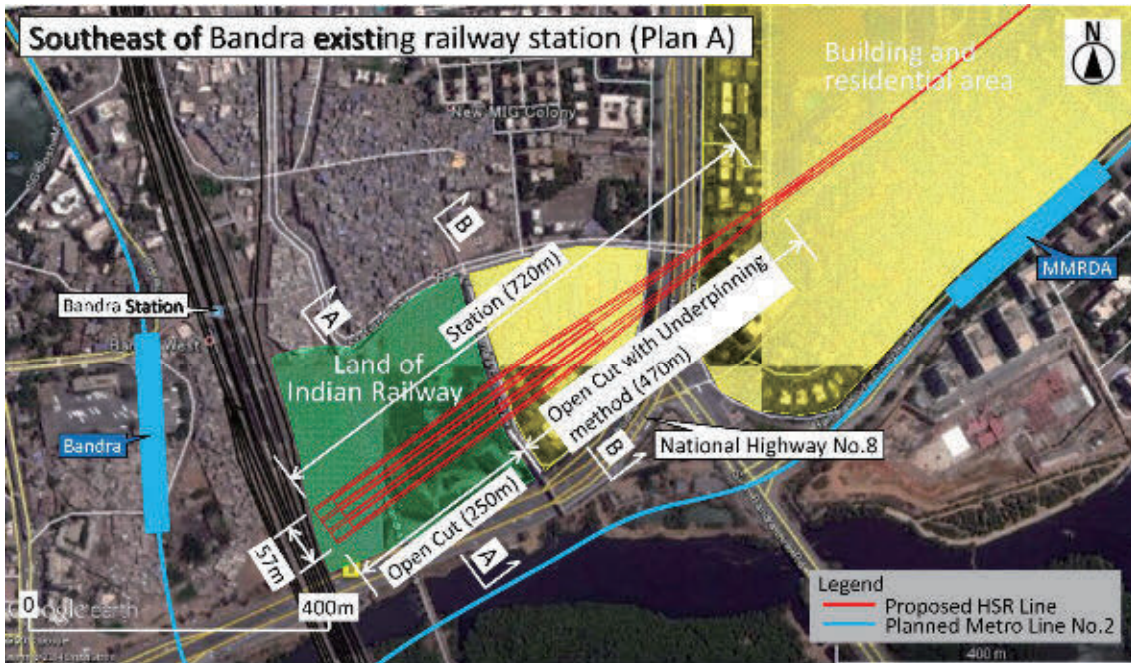

Source: Google earth, study team

Figure 4.7-47 Station Plan of Plan A (Southeast of Bandra Existing Railway Station)

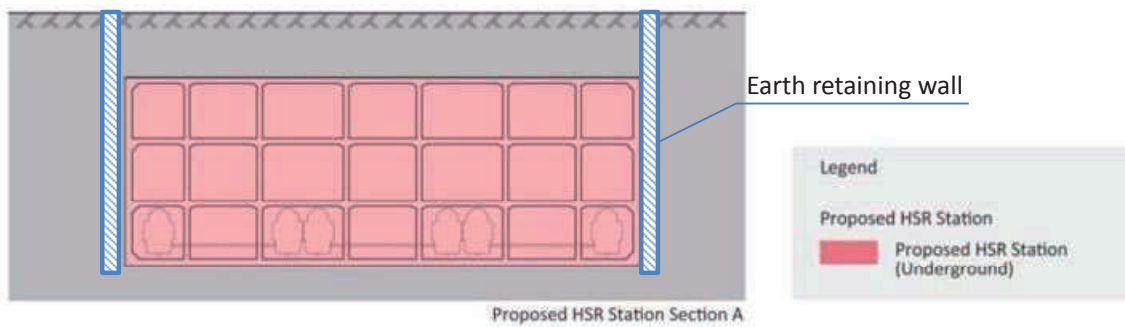

Source: Study team

Figure 4.7-48 Cross Section A-A of Station Plan of Plan A (Southeast of Bandra Existing Railway Station)

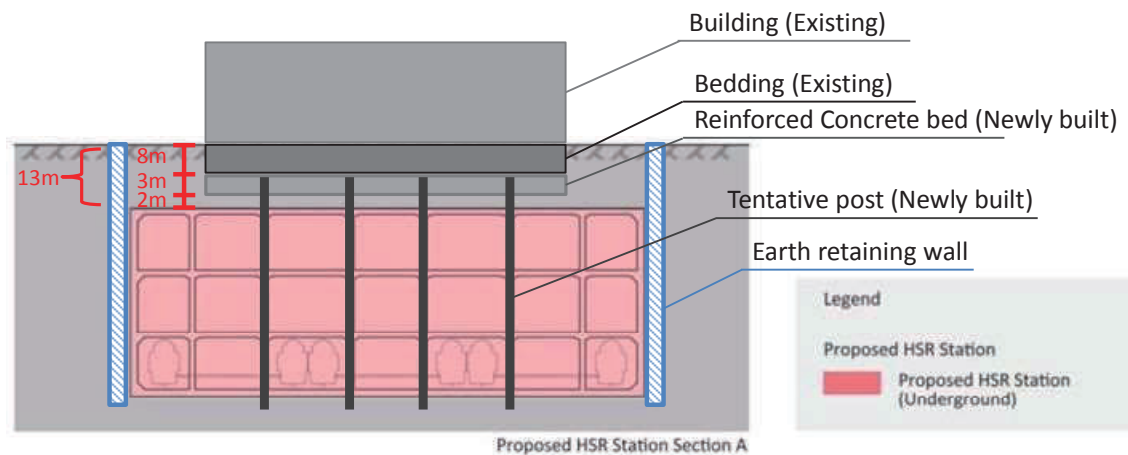

Source: Study team

Figure 4.7-49 Cross Section B-B of Station Plan of Plan A  
(Southeast of Bandra Existing Railway Station)

### Plan B

Main points of planning are as follows:

- Proposed Dadar HSR station is located between Western and Central existing railway station at underground.
- Dadar HSR station belongs to the land owned by Indian railway and the approach passes under existing ROB and Matunga central railway workshop.
- Open cut with underpinning method would be needed under existing ROB and workshop.
- Construction work for protection of existing railway line and the station would be needed due to adjacent operational line.
- Index of construction cost (station only) compared with BKC HSR station is 1.87.
- It takes 4 year and 11 months to construct this station only.





Source: Google earth, study team

Figure 4.7-50 Location of Plan B  
(Between Western & Central Dadar Existing Railway Stations)

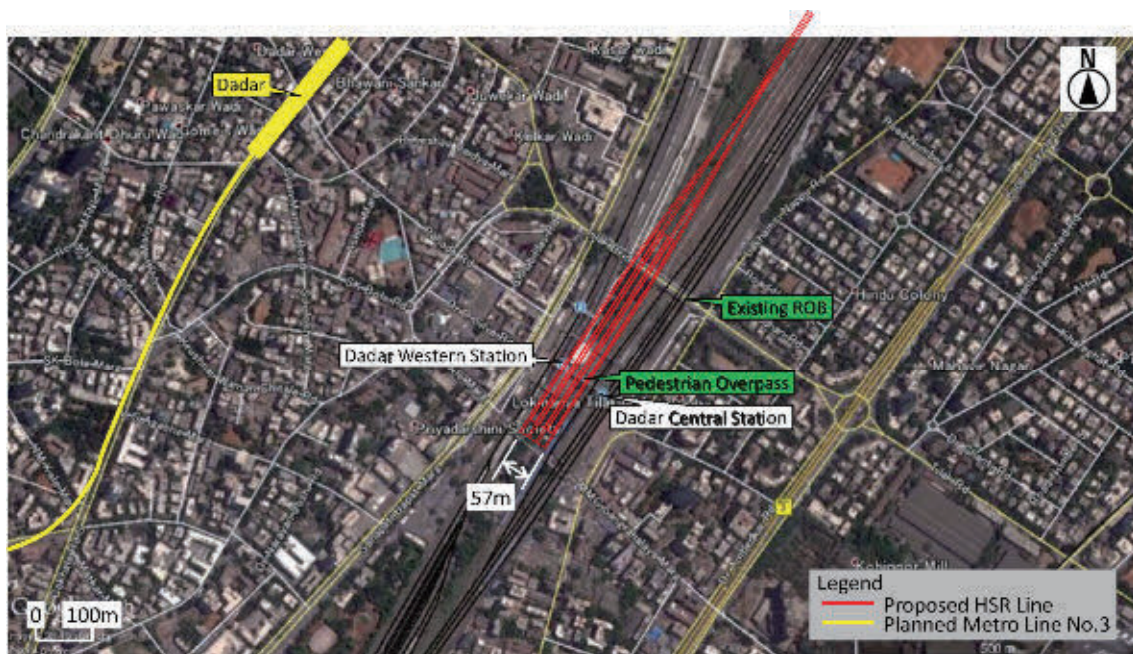

Source: Google earth, study team

Figure 4.7-51 Station Plan of Plan B  
(Between Western & Central Dadar Existing Railway Stations)



Table 4.7-10 Comparison of Station Location (Mumbai Area – More Detailed Study)

	Bandra Kurla Complex	Bandra (Plan A)	Dadar (Plan B)
Passenger demand	Covering CBD area	A little far from CBD area	A little far from CBD area
Connectivity with Mass Transport system	Good connectivity with Metro	Good connectivity with existing railway	Good connectivity with existing railway
Situation around the proposed HSR station	<ul style="list-style-type: none"> <li>▪ New development area</li> <li>▪ Good road access</li> </ul>	<ul style="list-style-type: none"> <li>▪ Already built-up area</li> <li>▪ Traffic congestion</li> </ul>	<ul style="list-style-type: none"> <li>▪ Already built-up area</li> <li>▪ Traffic congestion</li> </ul>
Position of station	Underground	Underground	Underground
Land acquisition	Land of MMRDA, or under road space	Partial land of Indian railway	Land of Indian railway
Geological & social conditions	Developing area	Swampy land, high buildings	Between WR & CR existing station
Access to proposed HSR station	Underground	Underground	Underground
Construction Period	4 years	4 years 9 months	4 years 11 months
Construction Cost	1.00	1.45	1.87
Total evaluation	✓✓	✓	✓

Source: Study team

## 2) Ahmedabad Area

There are 6 alternatives considered for station locations as Plan A and 3 alternatives considered for station locations as Plan B of Ahmedabad area.

### Plan A

Alternative proposed stations are planned as elevated station.

#### Ahmedabad

Main points of planning are as follows:

- The area is covering CBD area.
- The location has good connectivity with existing railway station and planned metro station.
- The area is already build-up area, therefore there is traffic congestion.
- The location of proposed HSR Station is owned by Indian railway.

#### Sabarmati

Main points of planning are as follows:

- The area is covering CBD area.
- The location has good connectivity with existing railway station and planned metro station.
- The location has a good road access.
- The location of proposed HSR Station has huge land of Indian railway.
- It is necessary that long elevated line cross over Sabarmati River.

### Ahmedabad + Sabarmati

Main points of planning are as follows:

- The areas are covering CBD and Sabarmati.
- The location each has good connectivity with existing railway station and planned metro station.
- Ahmedabad area is already build-up area, therefore there is traffic congestion. On the other hand, Sabarmati area has a good road access.
- The location of proposed HSR Station in Sabarmati area is a huge land of Indian railway.
- It is necessary that long elevated line cross over Sabarmati River.

Table 4.7-11 Comparison of Station Location (Ahmedabad Area – Plan A)

	Ahmedabad	Sabarmati	Ahmedabad +Sabarmati
Passenger demand	Covering CBD area	Covering CBD area	Covering CBD area and Sabarmati
Connectivity with Mass Transport system	Good connectivity with existing railway and Metro	Good connectivity with existing railway and Metro	Good connectivity with two existing railway and Metro
Situation around the proposed HSR station	• Already built-up area • Traffic congestion	• Already built-up area • Good road access	• Already built-up area • Good road access
Position of station	Elevated	Elevated	Elevated
Land acquisition	Land of Indian railway	Huge land of Indian railway	Huge land of Indian railway
Access to proposed HSR station	Elevated	Long elevated line over the river	Long elevated line over the river
Total evaluation	✓✓	✓	✓✓

Source: Study team

### Kankaria Freight Yard

Main points of planning are as follows:

- The location is a little far from CBD area.
- The location doesn't have good connectivity with mass rapid transport system.
- The area is already build-up area, therefore there is traffic congestion.
- The location of proposed HSR Station is owned by Indian railway as freight yard.

### Asarwa Railway Yard

Main points of planning are as follows:

- The location is a little far from CBD area.
- The location doesn't have good connectivity with mass rapid transport system.
- The area is already build-up area, therefore there is traffic congestion.
- The location of proposed HSR Station is owned by Indian railway.

### Vatwa Railway Yard

Main points of planning are as follows:

- The location is far from CBD area.
- The location doesn't have good connectivity with mass rapid transport system.
- The area is already build-up area; however has a good road access.
- The location of proposed HSR Station is owned by Indian railway as railway yard.
- In the case of setting a HSR station to Vatwa, the length of HSR route has the shortest elevated line.

Table 4.7-12 Comparison of Station Location (Ahmedabad Area – Plan A)

	Kankaria	Asarwa	Vatwa
Passenger demand	A little far from CBD area	A little far from CBD area	Far from CBD area
Connectivity with Mass Transport system	No connectivity with Mass Transport system	No connectivity with Mass Transport system	No connectivity with Mass Transport system
Situation around the proposed HSR station	<ul style="list-style-type: none"> <li>▪ Already built-up area</li> <li>▪ Traffic congestion</li> </ul>	<ul style="list-style-type: none"> <li>▪ Already built-up area</li> <li>▪ Traffic congestion</li> </ul>	<ul style="list-style-type: none"> <li>▪ Already built-up area</li> <li>▪ Good road access</li> </ul>
Position of station	Elevated	Elevated	Elevated
Land acquisition	Land of Indian railway(Freight yard)	Land of Indian railway	Huge land of Indian railway (Railway yard)
Access to proposed HSR station	Elevated	Elevated	Short elevated line
Total evaluation	✓	✓	✓

Source: Study team

#### a) Study of station plan in the case of juxtaposed Ahmedabad existing station

As for the case of juxtaposed Ahmedabad existing station, the more detailed study are conducted as shown in Figure 4.7-52 and Figure 4.7-53.

Main points of planning are as follows:

- It is planned that Ahmedabad HSR station is 3 layer structures, and 1st floor is for concourse 2nd floor is for track.
- It is planned that the proposed HSR station would be connected to Kalupur railway station (underground) of East - West Metro Corridor at elevated.
- It is planned that east and west existing station plaza would be connected with three pedestrian walkways (elevated) and one pedestrian walkways (underground).
- According to Draft Development Plan-2021 (2<sup>nd</sup> revised), CBD is located at west side of

existing railway station. It is recommended that the east side of existing railway is also planned as CBD because location of HSR station is planned on the east side of existing railway station.

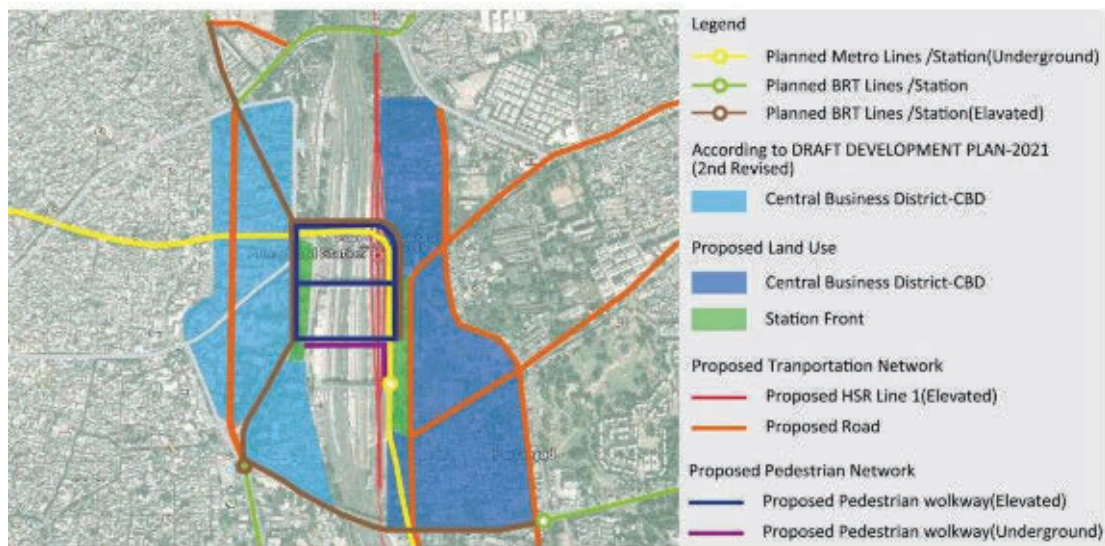

Source: Google earth, study team

Figure 4.7-52 Station Plan of Ahmedabad (Draft)

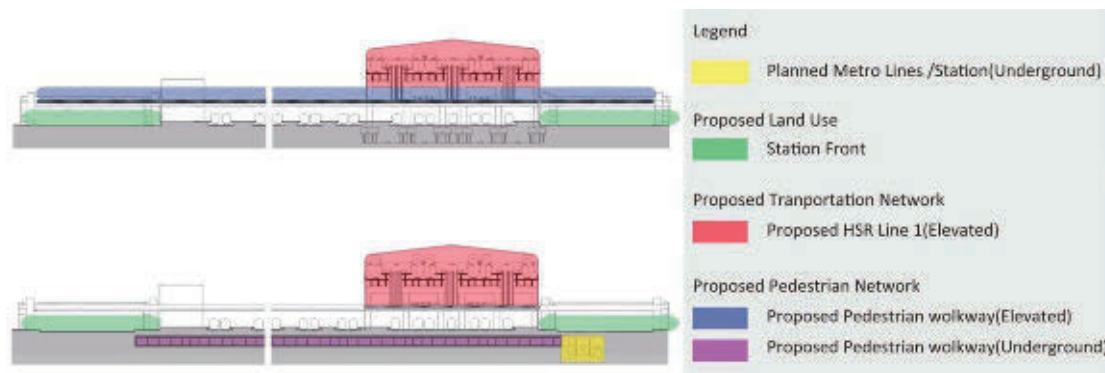

Source: Study team

Figure 4.7-53 Station Section of Ahmedabad (Draft)

## Plan B

Alternative proposed stations are planned as elevated station.

### Bopal

Main point of planning is as follows:

- The location is far from CBD area.
- The location doesn't have good connectivity with mass rapid transport system.
- The area is new development area and has a good road access.
- The location of proposed HSR Station is green field.

### Sarkhej

Main point of planning is as follows:

- The location is far from CBD area.
- The location has a good connectivity with existing railway station of single track and meter gauge.
- The area is already build-up area; however has a good road access.
- Land acquisition is necessary.

### Sabarmati

Main points of planning are as follows:

- The location is a little far from CBD area.
- The location has a good connectivity with existing railway station.
- The area is already build-up area; however has a good road access.
- The location of proposed HSR Station is owned by Indian railway as railway yard.



Table 4.7-13 Comparison of Station Location (Ahmedabad Area – Plan B)

	Bopal	Sarkhej	Sabarmati
Passenger demand	Far from CBD area	Far from CBD area	A little far from CBD area
Connectivity with Mass Transport system	No connectivity with Mass Transport system	Good connectivity with existing railway	Good connectivity with existing railway
Situation around the proposed HSR station	<ul style="list-style-type: none"> <li>• New development area</li> <li>• Good road access</li> </ul>	<ul style="list-style-type: none"> <li>• Already built-up area</li> <li>• Good road access</li> </ul>	<ul style="list-style-type: none"> <li>• Already built-up area</li> <li>• Good road access</li> </ul>
Position of station	Elevated	Elevated	Elevated
Land acquisition	Green Field	Land acquisition necessary	Huge land of Indian railway
Access to proposed HSR station	Elevated	Elevated	Long elevated line
Total evaluation	✓	✓	✓

Source: Study team

### 3) Virar area

In the stage of ITR-2, the study was conducted in the case that Virar HSR station was juxtaposed to Virar existing railway station as follows.

Figure 4.7-54 shows the estimated covering area of HSR along coastal area in Mumbai. Passengers from Chhatrapati Shivaji International Airport would transfer to BKC station by car or planning Metro Line-2 & 3. And also passengers from south side of the district between BKC station and Ulhas River would move to BKC station by Car through NH No.8 or existing railway. On the other hand, passengers from north side of this area would move to Virar area by existing railway because NH No.8 is far from Virar area and inconvenient to access this area. In the future, when the expressway is constructed, the passenger flow would be changed.

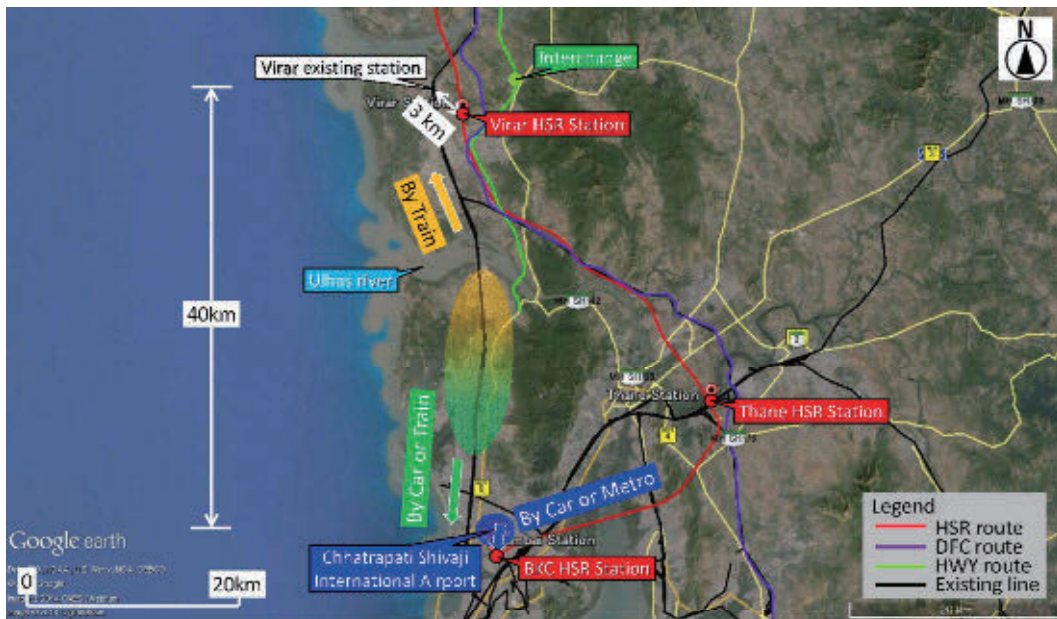

Source: Google earth, study team

Figure 4.7-54 Estimated Covering Area of HSR along Coastal Area in Mumbai

Figure 4.7-55 shows the estimated length of Viaduct section in the case of being juxtaposed to Virar existing station. Length of Viaduct section would be over 8 km before and after station. And also the height of Virar HSR station would be over 18 m due to Existing ROB. Furthermore, it would be necessary to adjust storage tracks yard on north side of existing railway station.

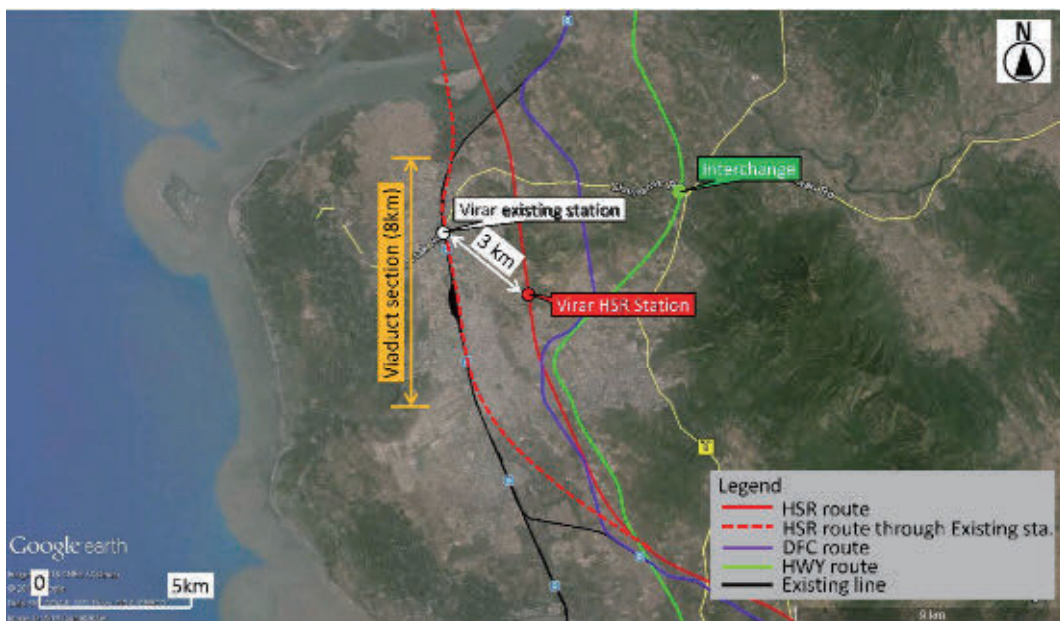

Source: Google earth, study team

Figure 4.7-55 Estimated Length of Viaduct Section in the Case of Being Juxtaposed to Virar Existing Station



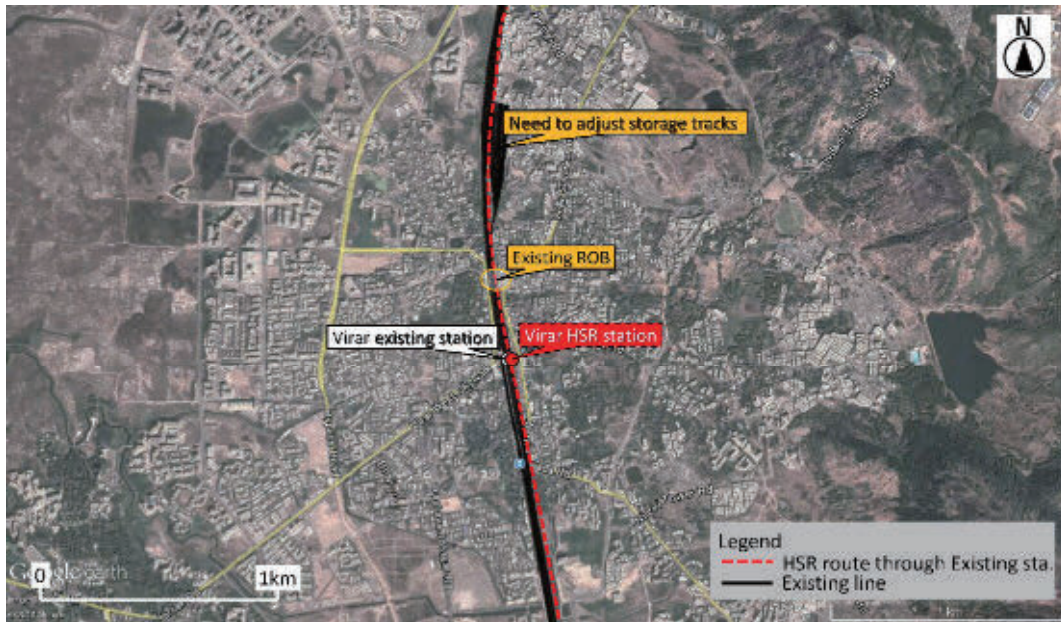

Source: Google earth, study team

Figure 4.7-56 Condition before and after Station in the Case of Being Juxtaposed to Virar Existing Station

Figure 4.7-57 shows the estimated necessary area for land acquisition in the case of being juxtaposed to Virar existing station. Land acquisition and resettlement along the HSR route would be needed due to constraint of narrow railway land (many buildings are adjacent with existing railway line).

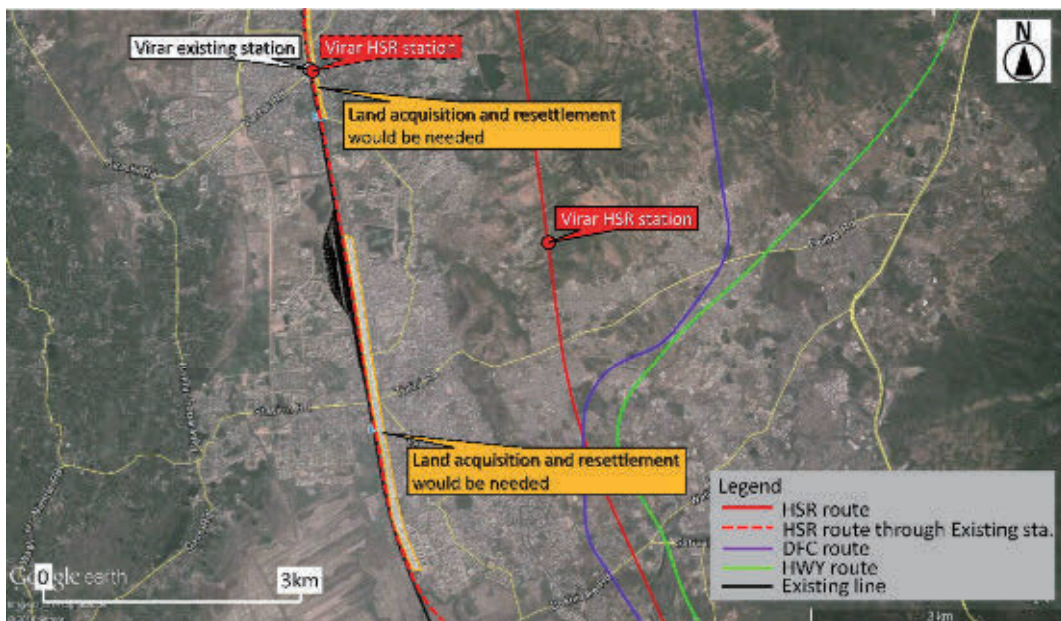

Source: Google earth, study team

Figure 4.7-57 Estimated Necessary Area for Land Acquisition in the Case of Being Juxtaposed to Virar Existing Station



Figure 4.7-58 shows HSR station juxtaposed to Virar existing station. It was planned to set the HSR station on the east side of existing railway station because there is the huge storage tracks yard on the west side of existing railway line, on the south side of existing railway station. Furthermore, it would be necessary to redevelopment the station plaza and vicinity for HSR station.



Source: Google earth, study team

Figure 4.7-58 HSR Station Juxtaposed to Virar Existing Station

Figure 4.7-59 shows the condition of proposed HSR station far from Virar existing station. There is a wide road under construction between proposed HSR station and Virar existing railway station. New access road to proposed HSR station would be needed.



Source: Google earth, study team

Figure 4.7-59 Condition of Proposed HSR Station Far from Virar Existing Station

4) Boisar and Dahanu area

There are 2 alternatives considered for station locations between Virar and Vapi. One is Boisar and another one is Dahanu. If setting the HSR station to Boisar, the distance between Virar and Boisar, Boisar and Vapi each is approx. 40 km and 66 km. On the other hand, if setting the HSR station to Dahanu, the distance between Virar and Dahanu, Dahanu and Vapi each is approx. 61 km and 4.7 km. In the view point of the distance between stations, there are same situations at the locations of Boisar and Dahanu. Detail consideration of each alternative is described as follows:



Source: Google earth, study team

Figure 4.7-60 Alternatives for Station Location between Virar and Vapi

Comparing with Boisar and Dahanu as the location of HSR station, Dahanu area have a little larger potential than Boisar in the view point of total and working population. On the other hand, Boisar is located at the big industrial area, if location of HSR station is planned near Boisar, the passenger demand of business trip can be incorporated.



Table 4.7-14 Comparison of Station Location (Boisar / Dahanu Area)

	Boisar	Dahanu
Passenger demand	Near from big Industrial area	A little far from Industrial area
Total population (Density) [1]	36,151 (4,062inh/sq.km)	50,287 (2,763inh/sq.km)
Working population (Density) [2]	14,372 (1,615inh/sq.km)	19,901 (1,093inh/sq.km)
Situation around the proposed HSR station	<ul style="list-style-type: none"> <li>•New development area</li> <li>•Good road access</li> </ul>	<ul style="list-style-type: none"> <li>•New development area</li> <li>•Good road access</li> </ul>
Position of station	Embankment	Embankment
Land acquisition	Green Field	Green Field
Access to proposed HSR station	Embankment	Embankment
Total evaluation	✓✓	✓

Note: [1] [2] Reference Population Census 2011

Source: Study team

#### 5) Valsad, Bilimora and Navsari

There are 3 alternatives considered for station locations between Vapi and Surat. One is Valsad, the second is Bilimora and the third is Navsari. If setting the HSR station to Valsad, the distance between Vapi and Valsad, Valsad and Surat each is approx.32 km and 63 km. If setting the HSR station to Bilimora, the distance between Vapi and Bilimora, Bilimora and Surat each is approx. 48 km and 47 km. If setting the HSR station to Navsari, the distance between Vapi and Navsari, Navsari and Surat each is approx. 69 km and 26 km. Detail consideration of each alternative is described as follows:



Source: Google earth, study team

Figure 4.7-61 Alternatives for Station Location between Vapi and Surat

Comparing with Valsad, Bilimora and Navsari as the location of HSR station, in the view point of the distance between stations, Bilimora is more preferable than Valsad and Navsari as the location of HSR station. However comparing Bilimora to Valsad and Navsari, Bilimora is not only a municipality or capital any sub-district or district but also a major industrial city.

In the meeting held on 2<sup>nd</sup> April by Ministry of Railway, where there are some members of Gujarat State and Western Railway, the intermediated station between Vapi and Surat are not decided due to a difficulty of the judgment. After that, Bilimora as the location of HSR station is decided by MOR.

**Table 4.7-15 Comparison of Station Location (Valsad / Bilimora / Navsari Area)**

Station Name	Valsad Station	Bilimora Station	Navsari Station
Population of Urban Area	139,764 (Valsad Urban Area)	53,187 (Bilimora Urban Area)	171,109 (Navsari Urban Area)
Population of Sub-district where the HSR station is located	415,140 (Valsad sub-district)	249,264 (Gandevi sub-district)	311,238 (Navsari sub-district)
Administrative / Industrial Importance	1) It is a municipality and capital of Valsad District. 2) Major industrial area. The Gundalv Industrial areas are close to HSR station. 3) Close to Arabian sea and tourist beaches.	1) It is neither a municipality nor capital of any sub-district or district. 2) Not a major industrial city. 3) Tourist destination in Waghai.	1) It is a municipality and capital of Navsari District. 2)The Sachin Industrial areas are between Navsari and Surat HSR station.
Total evaluation	✓ 1) Large catchment area 2) City is of administrative importance and an major industrial city.	✓✓ 1) Tourist destination will be expected 2) The possibility of new urban development	✓ 1) It has a large catchment area but is too close to Surat stn (only 26 km).

Source: Study team

## (5) Alignment view between proposed HSR stations

### 1) Between Mumbai and Thane

Main points of planning are as follows:

- The HSR station in Mumbai was planned at the Bandra Kurla Complex, which would be connected to the station of Metro Line-2 planned in the future.
- After BKC station at underground, the alignment runs through Thane Creek and the mountain at Navi Mumbai area by NATM tunnel.
- After passing the mountain at Navi Mumbai, the alignment crosses with NH No.8 at elevated.
- For going toward the north direction and avoiding high building areas at Nilje Gaon, the alignment was planned to turn from southwest to northwest with curve of 2,000 m radius.

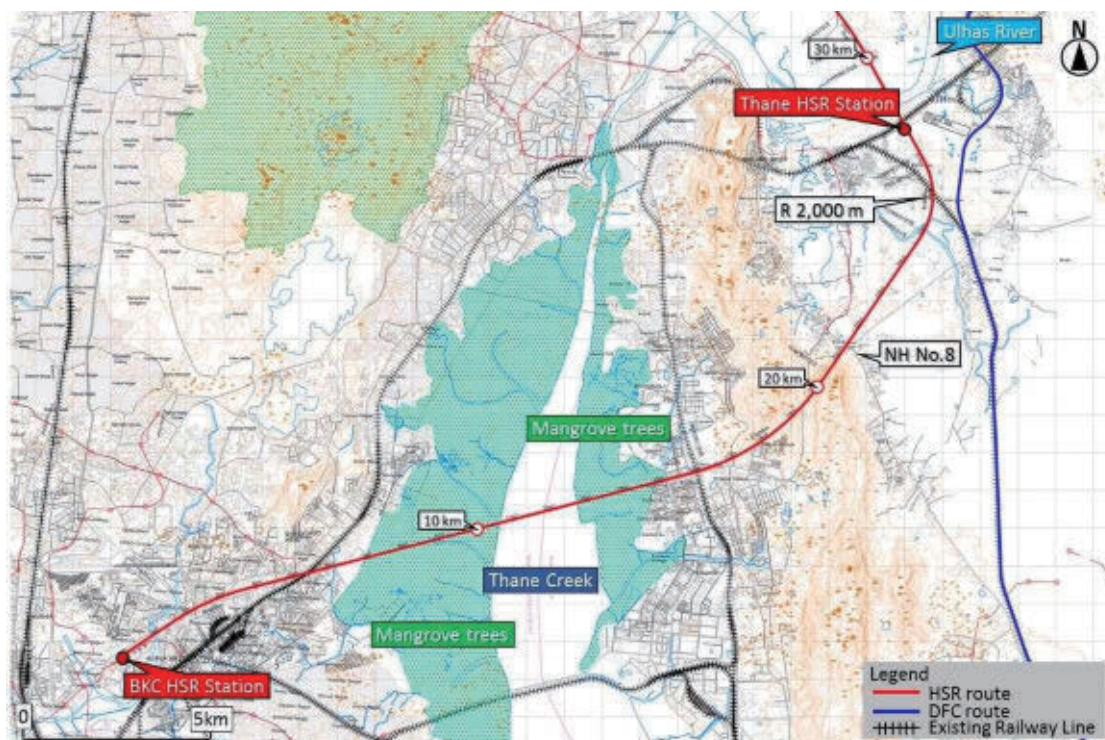

Figure 4.7-62 Final Proposed HSR Route between BKC Station and Thane Station

### 2) Between Thane and Virar

Main points of planning are as follows:

- After passing Thane station connected to the existing railway, the alignment crosses over the branch of Ulhas River by PC Box Girder (Cantilever method) with length of approx. 550 m.
- The HSR depot was planned at approx. 3 km from Thane station with considering the accessibility from NH No.3.
- The optimal alignment was planned to run with curve of 4,000 m radius for avoiding Sanjay Gandhi National Park and Tungareshwar Wild Life Sanctuary, however at this point the alignment crosses over the existing railway line and DFC line by steel truss bridge with maximum span of approx. 170 m.
- The alignment goes through two mountains by Tunnel almost paralleling the existing railway line and DFC line.
- There are three planning route, i.e. Expressway route, DFC route and HSR route on southeast side of Virar city.
- The alignment was planned to go under the planning Expressway route at 56.2 km, it would



- be necessary to negotiate with Expressway authority.
- The alignment was planned to cross over the DFC line at 62.7 km by steel truss bridge with the maximum span of approx. 150 m.

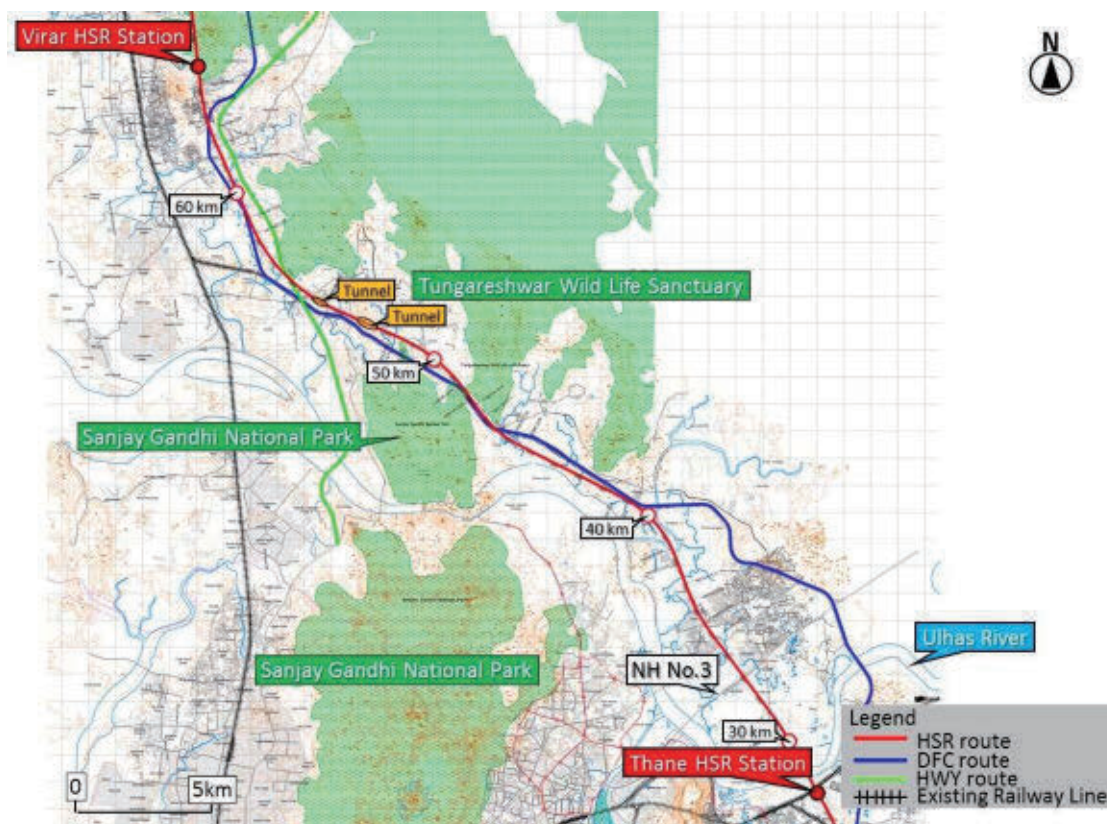

Figure 4.7-63 Final Proposed HSR Route between Thane Station and Virar Station

### 3) Between Virar and Boisar

- Virar station was planned to locate at the foot of mountains on east side of Virar city, so it would be necessary to construct the new road to access to the HSR station from city center.
- The alignment was planned to go through mountains on north side of Virar HSR station.
- After passing mountains by Tunnel on the north side of Virar HSR station and crossing over the existing railway line by RFO, the alignment crosses over Vaitarna River by bridge with length of approx. 2,150 m.
- At 82.7 km the alignment crosses over the existing railway line and DFC line by steel truss bridge with the maximum span of approx. 100 m.

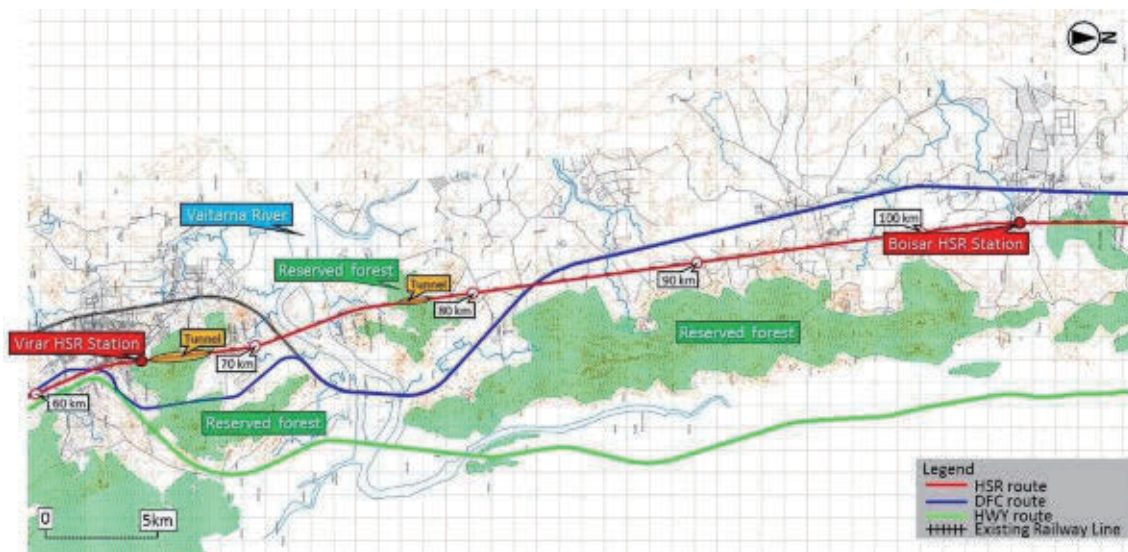

Figure 4.7-64 Final Proposed HSR Route between Virar Station and Boisar Station

#### 4) Between Boisar and Vapi

Main points of planning are as follows:

- Boisar HSR station was planned to located near Boisar road approx. 3 km on east side from Boisar city center.
- There are many reserved forests between Boisar and Vapi, therefore, the alignment was planned to go through these reserved forests as short as possible.

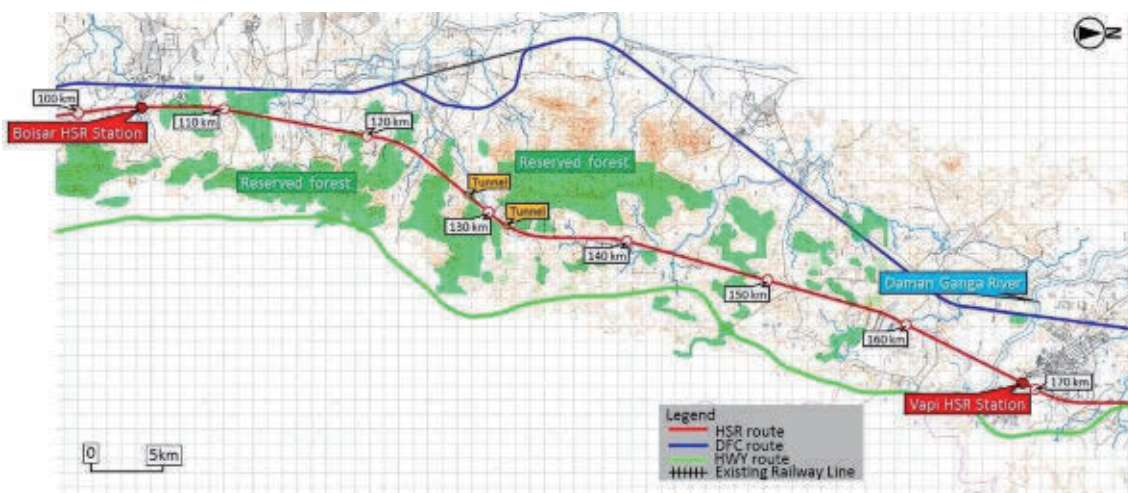

Figure 4.7-65 Final Proposed HSR Route between Boisar Station and Vapi Station

#### 5) Between Vapi and Billimora

Main points of planning are as follows:

- Vapi HSR station was planned to locate near SH No.185 approx. 4 km on the southeast from Vapi city center.
- The alignment crosses over NH No.8 at 210.6 km.



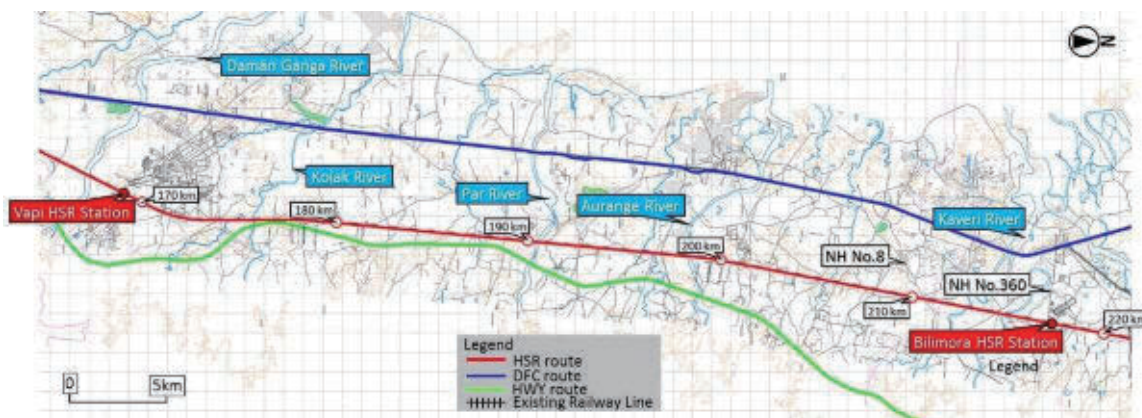

Figure 4.7-66 Final Proposed HSR Route between Vapi Station and Bilimora Station

6) Between Bilimora and Surat

Main points of planning are as follows:

- Billimora HSR station was planned to locate near NH No.360 approx. 4 km on the east from Bilimora city center.
- The alignment crosses over the existing railway line at 221.4 km and 263 km by RFO.



Figure 4.7-67 Final Proposed HSR Route between Bilimora Station and Surat Station

7) Between Surat and Bharuch

- Main points of planning are as follows:
- Surat HSR station was planned to locate near NH No.6 approx. 10 km on the east from Surat city center.
- The alignment crosses over Tapi River by PC box girder (Cantilever method) with length of approx. 550 m.
- At 286.3 km the alignment crosses over the existing railway line and DFC line by steel truss bridge with the maximum span of approx. 110 m.
- At 297.5 km the alignment crosses over planning Expressway by PC Box girder (Cantilever

- method) with the maximum span of approx. 70 m.
- At 317.5 km the alignment crosses over DFC line by PC Box girder (Cantilever method) with the maximum span of approx. 85 m.
- Before passing Bharuch station, the alignment crosses over Narmada River by PC Box Girder (Cantilever method) with length of approx. 1,200 m.

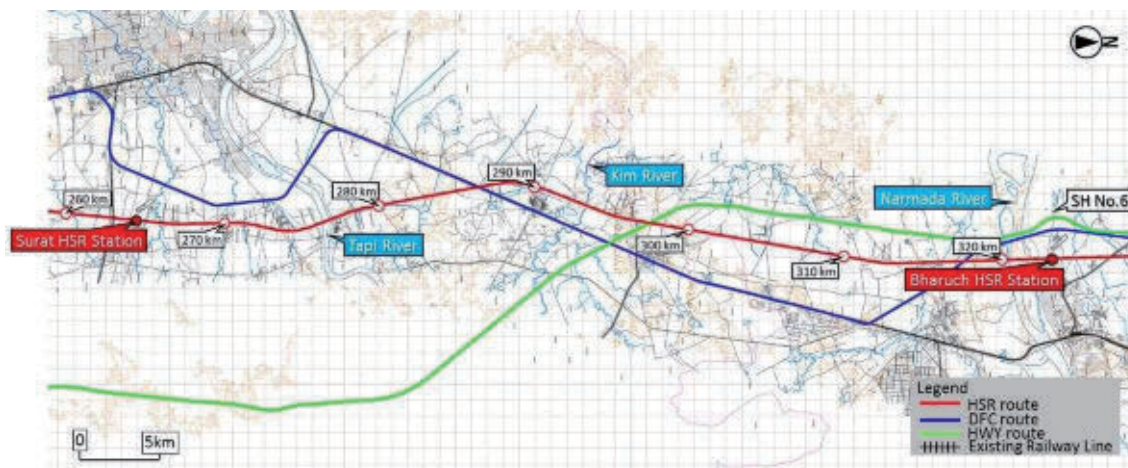

Figure 4.7-68 Final Proposed HSR Route between Surat Station and Bharuch Station

#### 8) Between Bharuch and Vadodara

Main points of planning are as follow:

- Bharuch HSR station was planned to locate near SH No.6 approx. 5 km on the west side from Bharuch city center.
- At 333.65 km and 384.95 km the alignment crosses over DFC line by steel truss bridge with the maximum span of approx. 110 m and by PC box girder (Cantilever method) with maximum span of approx. 55 m.
- From approx. 390 km to Vadodara HSR station the alignment goes along the existing railway line on the west side.

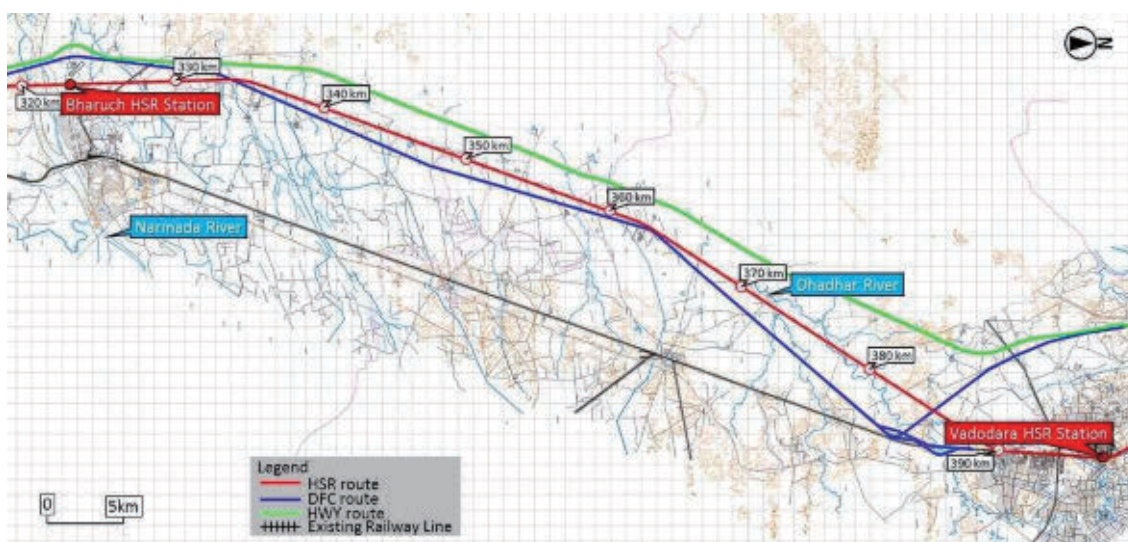

Figure 4.7-69 Final Proposed HSR Route between Bharuch Station and Vadodara Station



9) Between Vadodara and Anand/Nadiad

Main points of planning are as follows:

- Vadodara HSR station was planned to juxtapose with the existing railway station on the west.
- At 397.4 km the alignment crosses over the existing railway line from the west side to the east side by Gantry with the length of 300 m.
- The alignment goes along the east side of the main existing railway line from 398 km to 402 km.
- The alignment turn to the right by curve radius of 1,500 m and turn to the left by curve radius of 1,600 m for avoiding the industrial areas in Karachiya.
- At 416.05 km the alignment crosses over the planned expressway by PC box girder (Cantilever method) with the length of approx. 140 m.
- At 416.95 km the alignment crosses over Mahi River by PC box girder (Cantilever method) with the length of approx. 650 m.

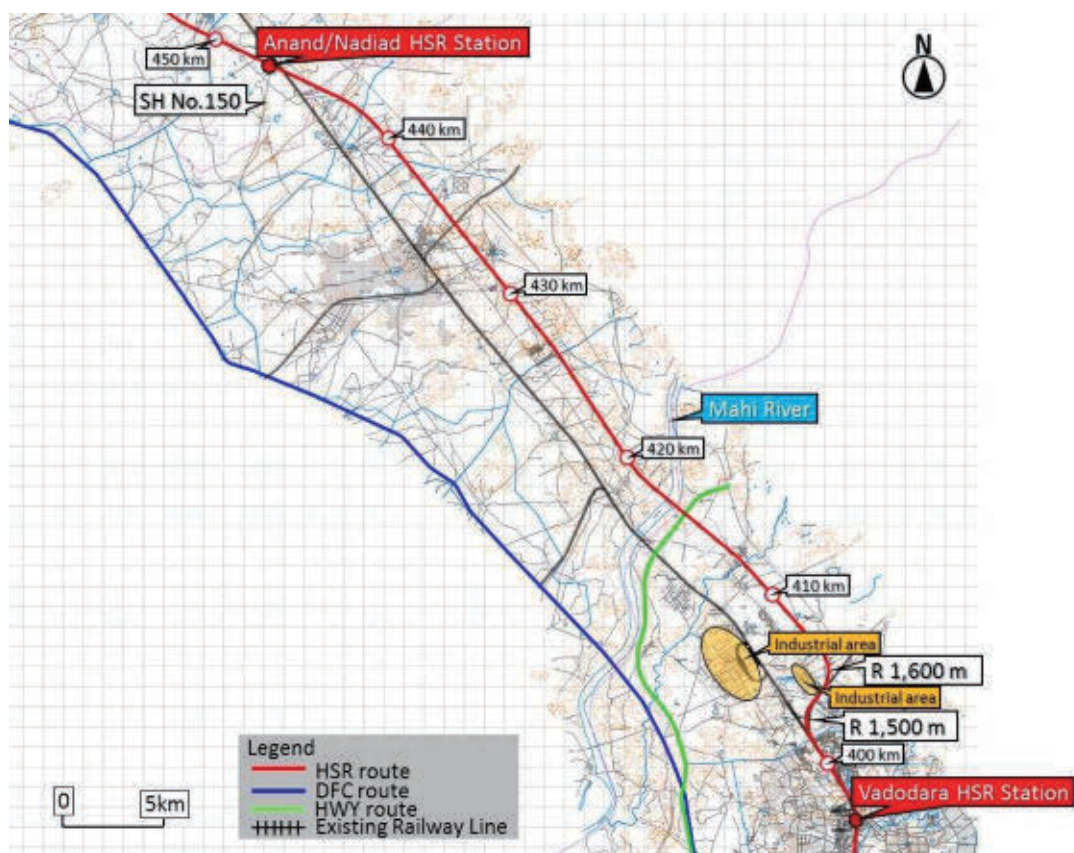

Figure 4.7-70 Final Proposed HSR Route between Vadodara Station and Anand/Nadiad Station

10) Between Anand/Nadiad and Ahmedabad

Main points of planning are as follows:

- Anand/Nadiad HSR station was planned to locate near SH No.150 on the west side of existing railway line between Anand city and Nadiad city.
- From approx. 489 km to the south side of Vatva existing station the alignment goes along the existing railway line on the west side and from here to Ahmedabad HSR station the alignment goes along the existing railway line on the east side.
- At 491.15 km the alignment crosses over the existing railway line by Gantry with the total

length of approx. 850 m.

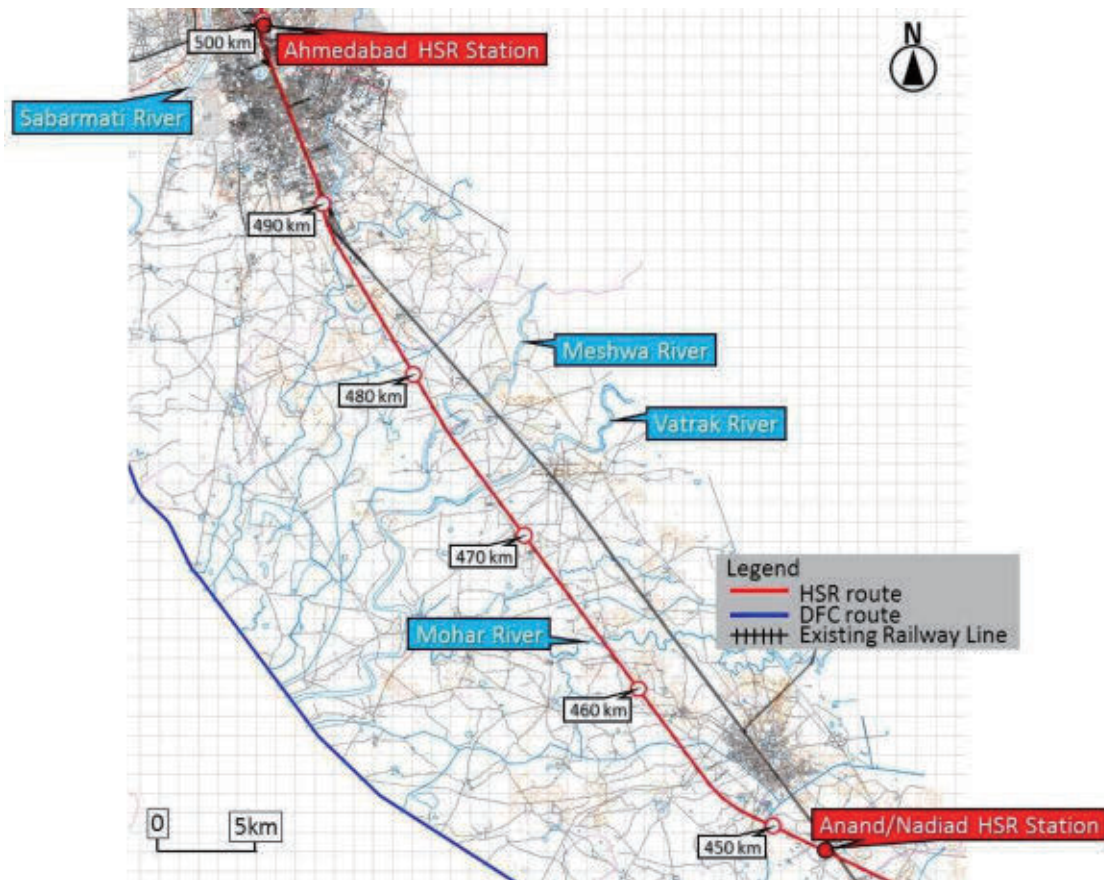

Figure 4.7-71 Final Proposed HSR Route between Anand/Nadiad Station and Ahmedabad Station

#### 11) Between Ahmedabad and Sabarmati

Main points of planning are as follows:

- Ahmedabad HSR station was planned to juxtapose with the existing railway station on the east.
- From Ahmedabad HSR station to 504.8 km the alignment goes along the existing railway line on the east side and at 504.10 km and crosses over Sabarmati River by PC box girder (Cantilever method) with the length of approx. 350 m.
- Sabarmati HSR station was planned to locate between the east and west existing railway stations.



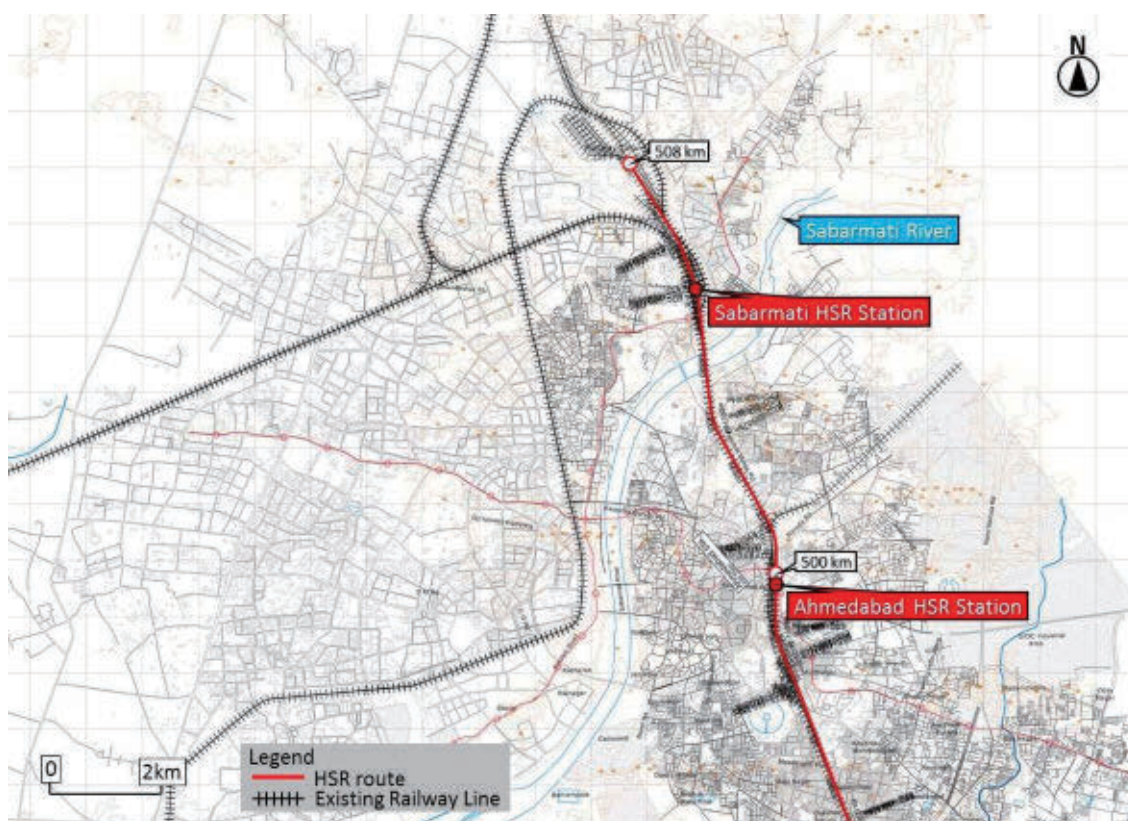

Figure 4.7-72 Final Proposed HSR Route between Ahmedabad Station and Sabarmati Station

(6) Study on usage of land of dedicated freight corridor

1) Difference of basic criteria between high speed railway and dedicated freight corridor

The comparison of basic criteria between high speed railway line and dedicated freight corridor is shown in Table 4.7-16. The curve radius of 6,000 m on HSR is minimum based on 350km/h of maximum designed speed, and the curve radius of 700 m on DFC is minimum for 100 km/h of maximum operation speed.

Due to ensuring promptness of HSR, HSR route should not be planned parallel to dedicated freight corridor.

Table 4.7-16 Comparison of Basic Criteria between High Speed Railway Line and Dedicated Freight Corridor

Items	High speed railway line	Dedicated freight corridor
Maximum operation speed (km/h)	320	100
Minimum curve radius (m)	6,000	700

Source: Study team

2) Case study on running parallel to dedicated freight corridor

The typical cross section of embankment and viaduct in the case that HSR route runs parallel to dedicated freight corridor as shown in Figure 4.7-73 and Figure 4.7-74.

As shown in Figure 4.7-73, if it is planned to construct embankment parallel to DFC and left land is available for HSR, additional land acquisition of approx. 28 m width would be needed. And



also as shown in Figure 4.7-74, even if it is planned to construct viaduct parallel to DFC and left land is available for HSR, additional land acquisition of approx. 2 m width would be needed and the construction cost would be higher than case of embankment.

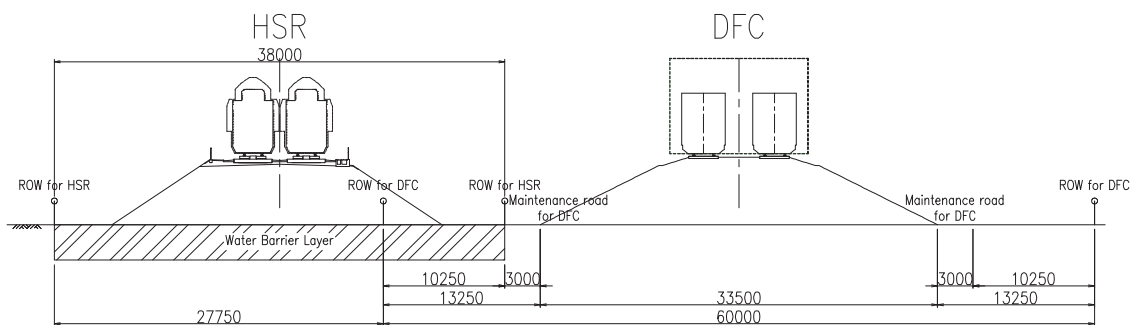

Source: Study team

Figure 4.7-73 Typical Cross Section of Embankment (Parallel to Dedicated Freight Corridor)

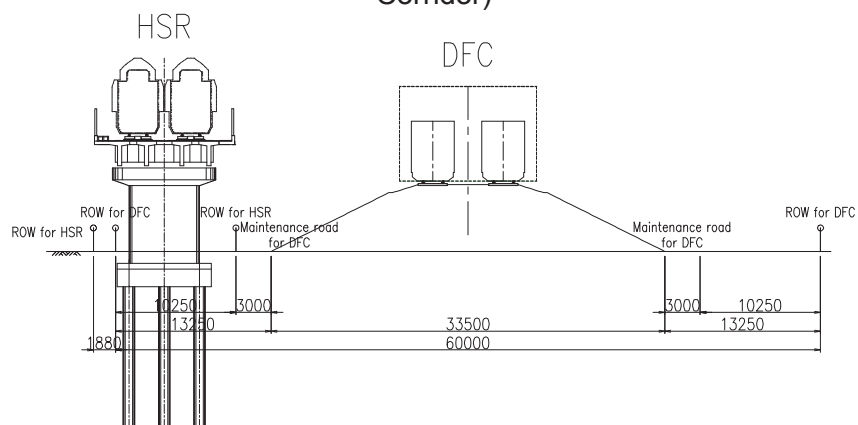

Source: Study team

Figure 4.7-74 Typical Cross Section of Viaduct (Parallel to Dedicated Freight Corridor)

### 3) Recommendation

DFC route is not preferable compared with HSR route for high speed train operation, and also will need the additional land to be acquired and cause longer work period than ordinary work due to required neighboring work with DFC route. Due to these reasons, usage of land of dedicated freight corridor is not recommended.

(7) Comparison of alternative depot locations

1) Alternative depot locations

The inspection system used for maintaining high speed trains includes daily inspection, regular inspection, bogie inspection, and general inspection. The car depots will be located near the two terminal stations and intermediate station that operate first and last trains. Specifically, car depots will be set up near Thane, Surat and Ahmedabad or Sabarmati.

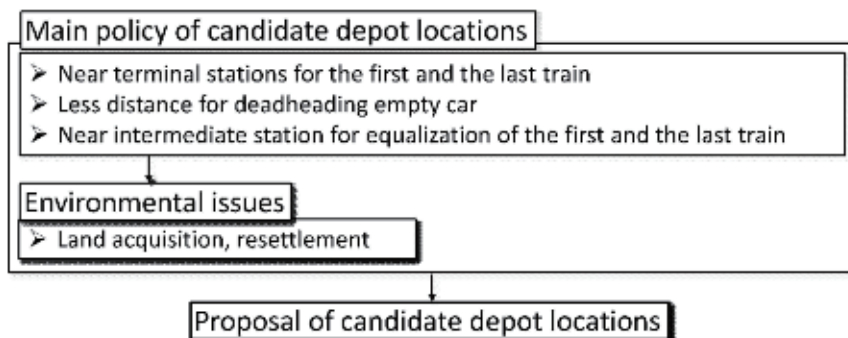

Source: Study team

Figure 4.7-75 Workflow for Candidate Depot Locations



Source: Google earth, study team

Figure 4.7-76 Candidate Depot Locations on HSR Route in ITR-1

Among them, plant facilities will be set up at the Thane depot or either of Ahmedabad and Sabarmati depot for bogie inspection and general inspection. The areas necessary for the storage tracks, depot tracks, and inspection tracks are estimated based on the assumption of a 12-cars and 16-cars configuration. The locations of car depots were selected accordingly.

a) Thane area

In view of an effective operation and management of rolling stock, the Car depot in Thane is considered near Mulgaya Pushkarni. Area for the site estimates approx. 39 Hectares (Length:

2300 m, Width: 170 m) at this stage. In the area, there are many green fields and dotted small-scale houses. Therefore, there are enough spaces to set the depot. The conditions are shown in Figure 4.7-77, Figure 4.7-78 and Figure 4.7-79.

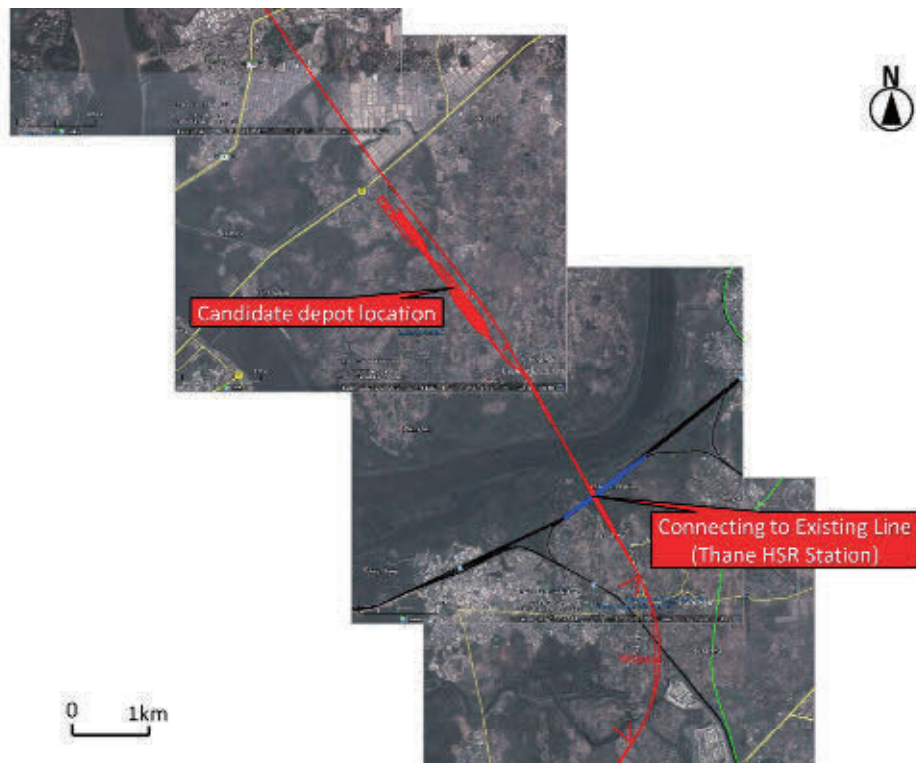

1

Source: Google Earth, study Team

Figure 4.7-77 Candidate Location for the Car Depot near Thane



Figure 4.7-78 Green Fields



Figure 4.7-79 Dotted Small-scale Houses

#### b) Surat area

In view of an effective operation and management of rolling stock, the Car depot in Surat is considered at north side of the proposed Surat Station. Area for the site estimates approx. 16 Hectares (Length: 1600 m, Width: 100 m) at this stage. In the area, there are many green fields. Therefore, there are enough spaces to set the depot. The conditions are shown in Figure 4.7-80,



Figure 4.7-81 and Figure 4.7-82.

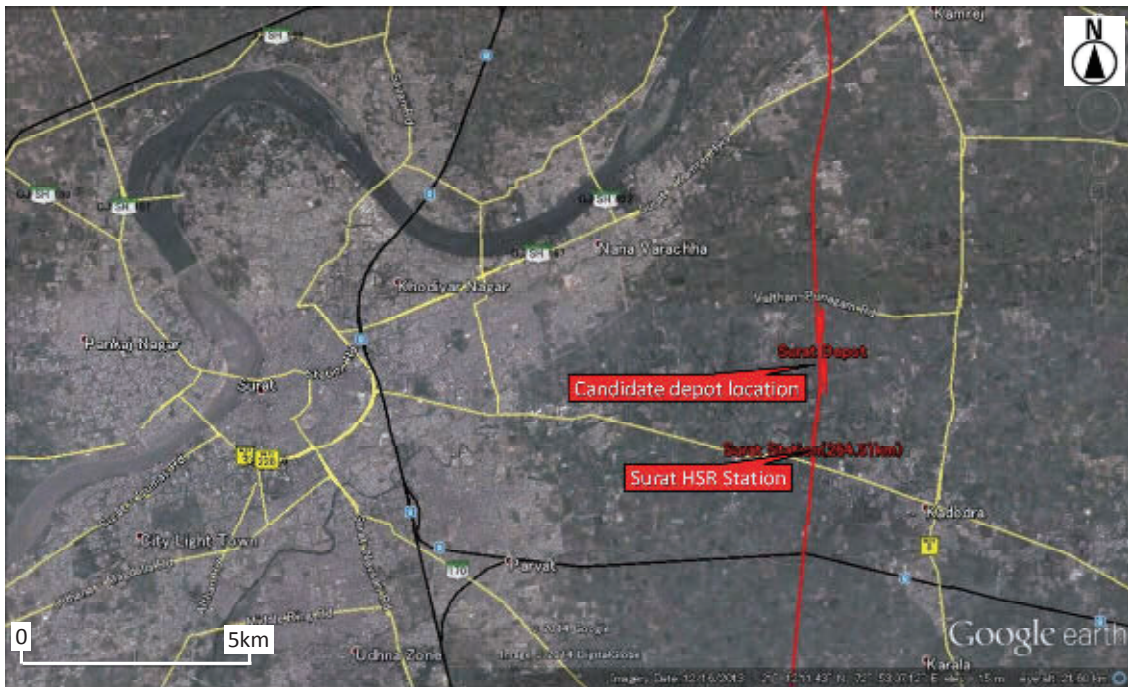

Source: Google Earth, study Team

Figure 4.7-80 Candidate Location for the Car Depot near Surat



Figure 4.7-81 Green Fields



Figure 4.7-82 Dotted Small-scale Houses

c) Ahmedabad area

There are 3 alternatives considered for depot location of Plan A route of Ahmedabad as shown in Figure 4.7-83.

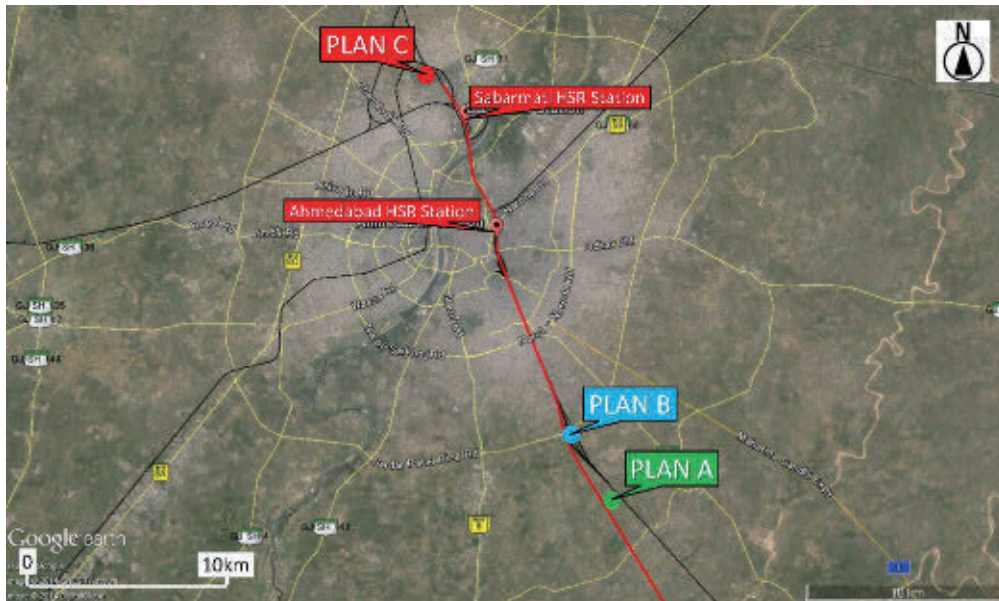

Figure 4.7-83 Three Alternatives Considered for Depot Location of Plan A Route of Ahmedabad

In view of an effective operation and management of rolling stock, the Car depot in Ahmedabad is considered near Devdi. Area for the site estimates approx. 16 Hectares (Length: 1800 m, Width: 90 m) at this stage. In the area, there are many fields. Therefore, there are enough spaces to set the depot. The conditions are shown in Figure 4.7-84, Figure 4.7-85 and Figure 4.7-86.



Source: Google Earth, study Team

Figure 4.7-84 Candidate Location No.1 for the Car Depot of Plan A Route of Ahmedabad





Figure 4.7-85 Green Fields



Figure 4.7-86 Prospecting Field of Oil Field

In view of an effective operation and management of rolling stock, the Car depot in Ahmedabad is considered at south side of the existing Vatwa Station. Area for the site estimates approx. 16 Hectares (Length: 1800 m, Width: 90 m) at this stage. This area is located at the huge storage yard owned by Western Railway. Therefore, it is necessary to coordinate with existing railway line and so on partly. The conditions are shown in Figure 4.7-87, Figure 4.7-88 and Figure 4.7-89.



Source: Google Earth, study Team

Figure 4.7-87 Candidate Location No.2 for the Car Depot of Plan A Route of Ahmedabad

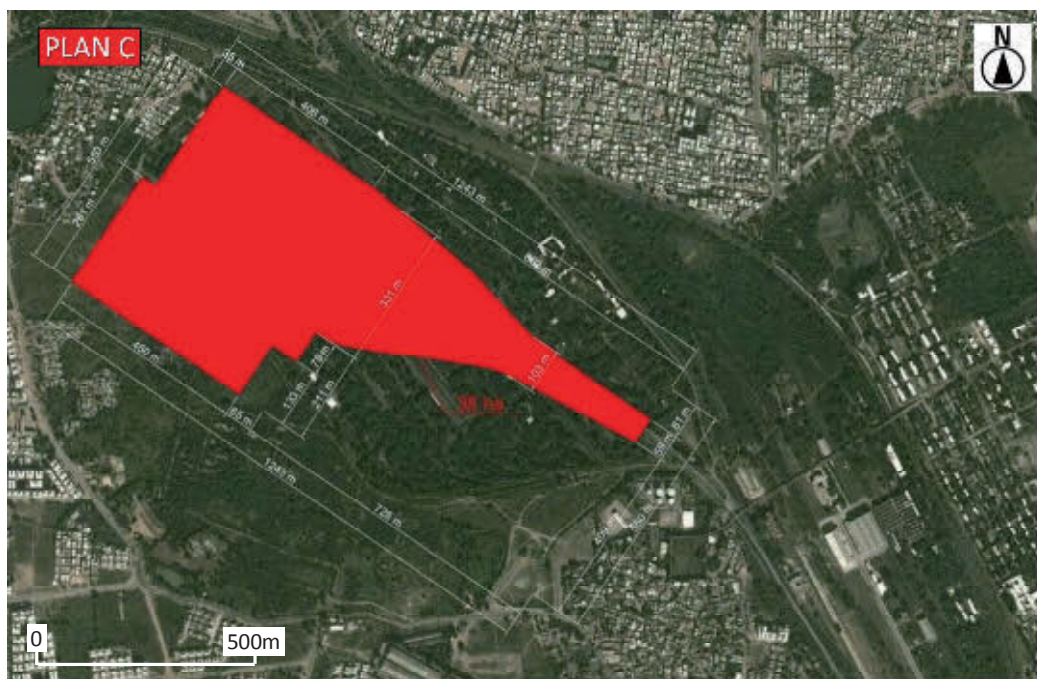

Figure 4.7-88 Huge Storage Yard



Figure 4.7-89 Shed

In view of an effective operation and management of rolling stock, the Car depot in Ahmedabad is considered at Sabarmati Existing Depot. Area for the site estimates approx. 38 at this stage. This area is located at the huge storage yard owned by Western Railway. Therefore, it is necessary to coordinate with existing railway line and so on partly. In addition, in the case of setting Depot and workshop in the area, there is the assumption that the HSR route extends to Sabarmati HSR station. The conditions are shown in Figure 4.7-90, Figure 4.7-91, Figure 4.7-92, Figure 4.7-93 and Figure 4.7-94.



Source: Google Earth, study Team

Figure 4.7-90 Candidate Location No.3 for the Car Depot of Plan A Route of Ahmedabad





Figure 4.7-91 Entrance of Proposed Depot Location



Figure 4.7-92 Warehouse for Rail Welding



Figure 4.7-93 Office of the Inspector



Figure 4.7-94 Scrapyard

Table 4.7-17 shows Comparison of three alternative depot locations in Ahmedabad.

Main points of comparisons are as follows:

- “Plan A” was located at Green field, on the other hand, “Plan B” & “Plan C” belong to huge storage yard owned by Western railway.
- Distance from Sabarmati HSR station is approx. 20 km in the case of “Plan A” & “Plan B.” And also how to approach to depot is turn back from Sabarmati HSR station. On the other hand, distance from Sabarmati HSR station is approx. 3 km in the case of “Plan C.” And also how to approach to depot is direct from Sabarmati HSR station.
- In the view point of resettlement of existing railway facilities, “Plan C” is needed more than “Plan A” and “Plan B”. However, at present, the areas have not been used effectively. To setting this depot in the areas could be solved by cooperation with Western railway.

Table 4.7-17 Comparison of Alternative Depot Locations in Ahmedabad

Item	PLAN A	PLAN B	PLAN C
Location	Devdi	Near Sardar Patel Ring Road	Sabarmati
Land acquisition	Green field (Some oil Prospecting fields)	Huge storage yard owned by Western Railway	Huge storage yard owned by Western Railway
Distance from station	21 km (from Sabarmati HSR station)	17 km (from Sabarmati HSR station)	3 km (from Sabarmati HSR station)
Approach to depot	Turnback from Sabarmati HSR station	Turnback from Sabarmati HSR station	Direct from Sabarmati HSR station
Resettlement of existing railway facilities	None	A little	Too much
Environment issues	Large land acquisition would be needed	Cooperation with Western Railway would be needed	Cooperation with Western Railway would be needed
Total evaluation	✓	✓	✓✓

Source: Study Team

Table 4.7-18 shows comparison of two alternative workshop locations on HSR route.

Main points of comparisons are as follows:

- “Plan A” was located at Green field in Thane, on the other hand, “Plan B” belong to huge storage yard owned by Western railway in Sabarmati.
- Distance from near HSR terminal stations is approx. 30 km in “Plan A” and approx. 3 km in “Plan B.” “Plan B” is much shorter than “Plan A”.
- “Plan B” is easier than “Plan A” in the view point of approach to depot.
- “Plan B” is easier than “Plan A” in the view point of ensuring personnel.

Table 4.7-18 Comparison of Alternative Workshop Locations on HSR Route

Item	PLAN A	PLAN B
Location	Thane	Sabarmati
Land acquisition	Green field (Some oil Prospecting fields)	Huge storage yard owned by Western Railway
Distance from station	30 km (from BKC HSR station)	3 km (from Sabarmati HSR station)
Approach to depot	Turnback from BKC HSR station	Direct from Sabarmati HSR station
Ensuring personnel	Not easier than PLAN B	Easy
Resettlement of existing railway facilities	None	Too much
Environment issues	Land acquisition would be needed	Cooperation with Western Railway would be needed
Total evaluation	✓	✓✓

Source: Study Team

## 2) Conclusion of alternative depot locations

On the HSR route of length of 500 km, the location of depot should be considered to operate the train smoothly based on train operating time zone and demand forecast. Considering the equalization of the first and the last train, the location would be desirable near terminal stations and intermediate station as described above.

At the time of ITR-1, based on this policy these locations were planned near Thane HSR station, Surat HSR station and Ahmedabad HSR station (3 locations). However at the time of ITR-2, in order to achieve a reduction of the total construction costs by avoiding duplication of facilities such as repair equipment, the locations were planned near Thane HSR station and Sabarmati HSR station (2 locations). It should be noted that capacity of Surat depot distributed to two depots near terminal stations.



Source: Google earth, study team

Figure 4.7-95 Final Candidate Depot Locations on HSR Route in ITR-2

It is not possible to set the depot near Mumbai HSR station due to difficulty of land acquisition, so it would be necessary to secure a site where the forward direction from Mumbai HSR station, and near Thane HSR station.

It was proposed that the huge land of Western Railway on north side of Sabarmati HSR station should be utilized as a site for depot.

It would be necessary to secure a site for workshop in view point that there is the advantage on railway facilities and train operation in the case of juxtaposing to the depot. There is a huge Western Railway land on north side of Sabarmati HSR station, therefore, it would be possible to set the depot with workshop. And also, the location of workshop would be desirable in the view of securing mechanical engineer because Ahmedabad is industrial area.

### a) Thane area

At the time of ITR-1, the location of Thane depot was planned on west side of HSR route after crossing over Ulhas River. However, the total length extended approx. 100 m, because about half of capacity planned in Surat depot is transferred to Thane Depot. Due to this reason, it was interfered with Anjurdive area and NH No.3. In the view of the above, it was proposed to set Thane Depot on east side of HSR route after passing Bharodi area as shown Figure 4.7-96.

It was planned that this depot was tandem type that running length of train was shorter in depot and this area estimated approx. 33 Hectares (length: approx. 2.400 m, maximum width: approx. 180 m).





Source: Google Earth, study Team

Figure 4.7-96 Final Candidate Location for the Car Depot near Thane

#### b) Ahmedabad area

The Sabarmati existing station was located at a part of the existing depot, locomotive factory, maintenance machinery and equipment production factory, scrapyards and so on owned by Western Railway. It was planned to set the HSR station at elevated to be parallel to the existing railway line, and to set the HSR depot at plaza for scraped cars located on the back within Western Railway land.

Due to the shape of this site, the facilities such as storage track groups, inspection shed and factory buildings spread in a fan shape, so it was planned to replace trains via lead tracks. This area estimated approx. 67 Hectares (length except lead tracks: approx. 680 m, maximum width: approx. 680 m).



Source: Google Earth, study Team

Figure 4.7-97 Final Candidate Location for the Car Depot with Workshop (Sabarmati)

## (8) Result of Comprehensive Evaluation

### 1) Comprehensive review

The followings described station locations and optimal alignments as the result of the above comparisons. Including the two terminals, there are altogether 12 stations. The route length is approx. 505 km and the average distance between stations is approx. 46 km as shown Table 4.7-19.

**Table 4.7-19 Chainage and Interval between Proposed Stations**

No.	Proposed station	Total Length (km)	Station Interval (km)
1	Mumbai	0.00	
			27.92
2	Thane	27.92	
			37.00
3	Virar	64.92	
			39.43
4	Boisar	104.35	
			64.55
5	Vapi	168.90	
			48.40
6	Bilimora	217.30	
			47.15
7	Surat	264.45	
			58.61
8	Bharuch	323.06	
			73.85
9	Vadodara	396.91	
			50.20
10	Anand/Nadiad	447.11	
			52.64
11	Ahmedabad	499.75	
			5.62
12	Sabarmati	505.37	

Source: Study Team

Main points of station locations are as follows:

#### a) Mumbai area

- Proposed station location in Mumbai area is Bandra Kurla Complex at underground.
- Proposed route goes through Thane Creek by tunnel.

#### b) Thane area

- Proposed Thane station connects to existing railway line.

#### c) Virar area

- Proposed station location of Virar is vacant green field between mountains on east side of Virar city.

#### d) Boisar area

- Proposed station location of Boisar is vacant green field a little far from Boisar Road on east

side of Boisar city.

e) Vapi area

- Proposed Vapi station is located near State Highway No.185 at suburb of the southeast side Vapi.

f) Bilimora area

- Proposed Bilimora station is located near State Highway No.15 at suburb of the east side Bilimora.

g) Surat area

- Proposed Surat station is located near National highway No.6 at suburb of the east side Surat.

h) Bharuch area

- Proposed Bharuch station is located near State Highway No.6 at suburb of the west side Bharuch.

i) Vadodara area

- Proposed Vadodara Station is juxtaposed to the existing Vadodara railway station.

j) Anand / Nadiad area

- Proposed Anand / Nadiad station is located near National highway No.8 between Anand and Nadiad.

k) Ahmedabad area

- Proposed Ahmedabad Station is juxtaposed to the existing Ahmedabad railway station.
- Besides Ahmedabad HSR station, Sabarmati HSR station is recommended considering road access to the station.

Comprehensive views for optimal alignments are shown in Figure 4.7-98, Figure 4.7-99, Figure 4.7-100 and Figure 4.7-101.

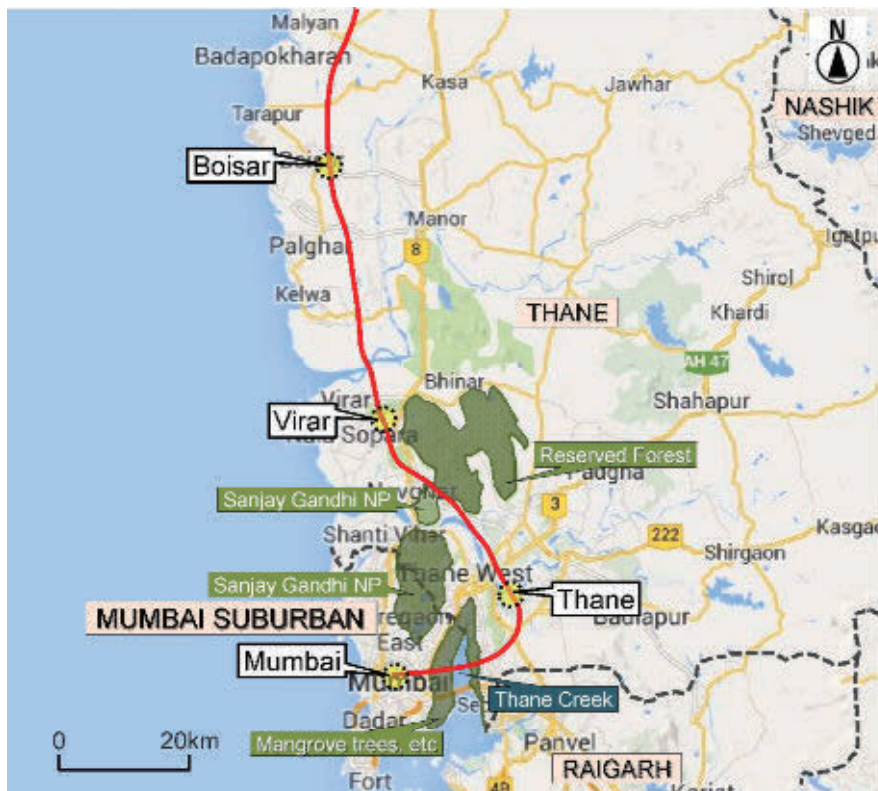

Source: Google Map, study Team  
Figure 4.7-98 Optimal Route and Station Location of Mumbai, Thane, Virar and Boisar



Source: Google Map, study Team  
Figure 4.7-99 Optimal Route and Station Location of Vapi and Bilimora



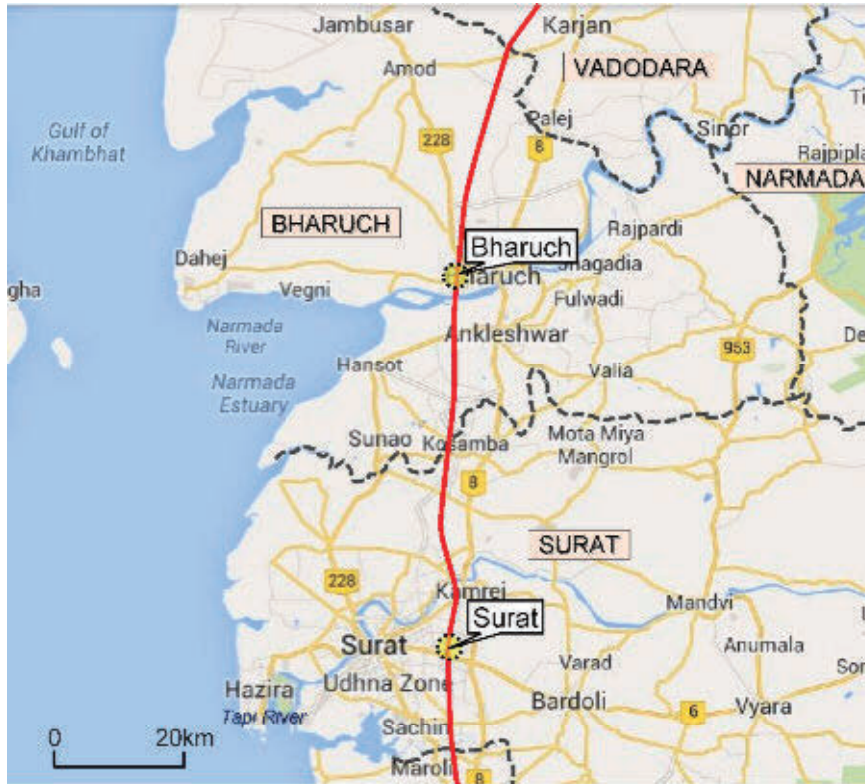

Source: Google Map, study Team  
Figure 4.7-100 Optimal Route and Station Location of Surat and Bharuch

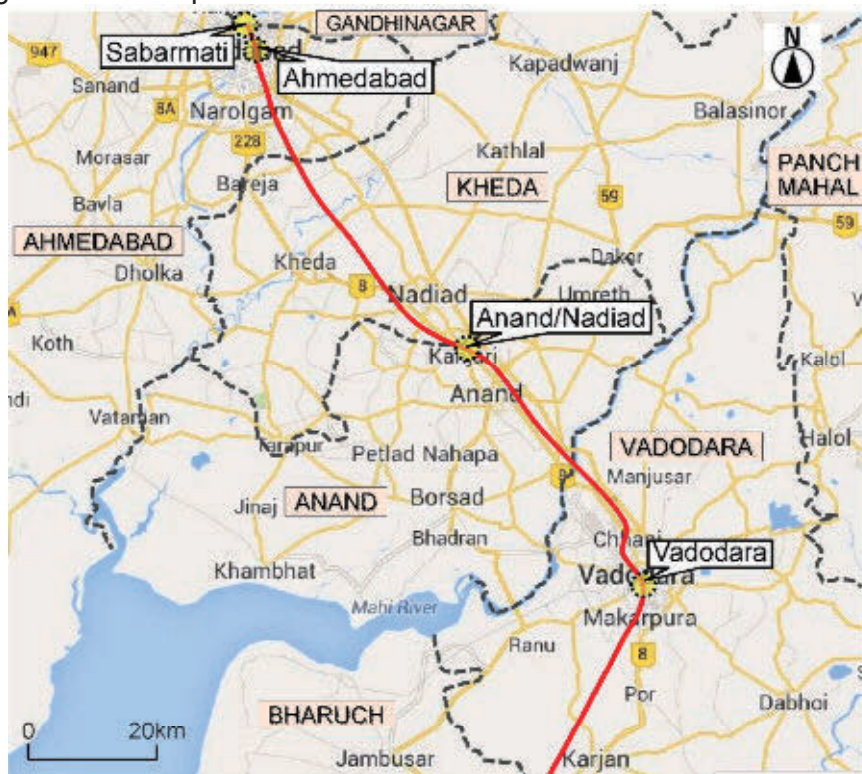

Source: Google Map, study Team  
Figure 4.7-101 Optimal Route and Station Location of Vadodara, Anand/Nadiad, Ahmedabad and Sabarmati

## 2) Alignment information of optimal routes

The minimum curve radius was applied to 6,000 m or more for the realization of operating speed with 320 km (design speed with 350 km) on the HSR route. And also the vertical alignment was designed with the maximum curve of 25,000 m radius and maximum gradient of 25 ‰ on the HSR route.

Table 4.7-20 shows the detail information of the horizontal and vertical alignment of the HSR route.

**Table 4.7-20 Horizontal and Vertical Alignment of HSR Route**

Name of Station	Chainage (m)	R/L	Radius (m)		Distance (m)	Gradient (‰)	Distance (m)	Gradient change point (m)
Mumbai	0				1,332	-3.0	1,000	-5.175
	1,000					-6.5	5,800	-8.175
	1,332	R	6,000	BTC				
	2,012			BCC				
	3,312			ECC				
	3,992			ETC	11,532			
	6,800					3.0	5,850	-45.610
	12,650					5.0	2,000	-28.060
	14,650					7.1	6,700	-18.060
	15,524	L	6,000	BTC				
	16,204			BCC				
	19,812			ECC				
	20,492			ETC	4,050			
	21,350					-12.0	964	29.566
	22,314					0.0	3,156	18.000
	24,542	L	2,000	BTC				
	24,952			BCC				
	25,470					4.0	1,750	18.000
	26,759			ECC				
	27,169			ETC	2,773			
	27,220					0.0	1,780	25.000
Thane	27,920							
	29,000					-8.0	812	25.000
	29,812					0.0	15,238	18.501
	29,942	L	6,000	BTC				
	30,622			BCC				
	30,754			ECC				
	31,434			ETC	3,322			
	34,756	R	6,000	BTC				
	35,436			BCC				
	36,443			ECC				
	37,123			ETC	794			
	37,916	L	4,000	BTC				
	38,526			BCC				

Name of Station	Chainage (m)	R/L	Radius (m)		Distance (m)	Gradient (‰)	Distance (m)	Gradient change point (m)
	40,888			ECC				
	41,498			ETC	3,706			
	45,050					10.0	1,150	18.501
	45,204	R	4,000	BTC				
	45,814			BCC				
	46,200					0.0	4,871	29.999
	47,153			ECC				
	47,763			ETC	213			
	47,976	L	6,000	BTC				
	48,656			BCC				
	51,071					-12.0	1,056	29.999
	51,230			ECC				
	51,910			ETC	1,894			
	52,126					3.0	1,374	17.333
	53,500					-4.0	2,114	21.454
	53,805	R	6,000	BTC				
	54,485			BCC				
	55,614					0.0	1,187	13.000
	56,800					3.0	3,450	13.000
	58,274			ECC				
	58,954			ETC	2,837			
	60,250					6.7	2,450	23.351
	61,792	R	6,000	BTC				
	62,472			BCC				
	62,700					0.0	2,920	39.717
	63,558			ECC				
	64,238			ETC	4,643			
Virar	64,920							
	65,620					-8.0	2,465	39.717
	68,085					0.0	6,648	20.000
	68,880	L	6,000	BTC				
	69,560			BCC				
	70,347			ECC				
	71,027			ETC	2,683			
	73,710	R	6,000	BTC				
	74,390			BCC				
	74,733					5.0	3,604	20.000
	75,079			ECC				
	75,759			ETC	26,261			
	78,336					-8.1	2,827	38.019
	81,164					10.0	1,536	15.255

Name of Station	Chainage (m)	R/L	Radius (m)		Distance (m)	Gradient (‰)	Distance (m)	Gradient change point (m)
	82,700					-10.0	835	30.618
	83,535					2.0	1,265	22.268
	84,800					-1.5	3,400	24.832
	88,200					3.9	1,600	19.792
	89,800					0.0	3,763	26.000
	93,563					1.0	2,037	26.000
	95,600					-0.4	5,600	28.037
	101,200					-1.2	1,638	26.001
	102,020	R	8,000	BTC				
	102,640			BCC				
	102,838					0.0	2,762	24.000
	103,027			ECC				
	103,647			ETC	4,257			
Boisar	104,350							
	105,600					1.3	1,560	24.000
	107,160					0.0	4,754	26.000
	107,904	R	6,000	BTC				
	108,584			BCC				
	109,041			ECC				
	109,721			ETC	10,894			
	111,914					-3.0	2,080	26.000
	113,993					4.4	907	19.720
	114,900					1.2	1,982	23.677
	116,882					0.0	2,518	26.000
	119,400					2.4	1,150	26.000
	120,550					-0.2	3,900	28.772
	120,615	R	6,000	BTC				
	121,295			BCC				
	123,671			ECC				
	124,351			ETC	5,855			
	124,450					3.7	4,601	28.000
	129,051					10.0	1,955	45.023
	130,206	L	6,000	BTC				
	130,886			BCC				
	131,005					4.0	2,828	64.568
	133,833					-14.0	1,348	75.881
	134,258			ECC				
	134,938			ETC	3,217			
	135,181					0.0	1,169	57.012
	136,350					-14.0	787	57.012
	137,137					0.0	3,896	46.000

Name of Station	Chainage (m)	R/L	Radius (m)		Distance (m)	Gradient (‰)	Distance (m)	Gradient change point (m)
	138,155	R	6,000	BTC				
	138,835			BCC				
	139,709			ECC				
	140,389			ETC	16,846			
	141,033					-10.0	1,692	45.996
	142,725					11.1	2,125	29.079
	144,850					8.0	3,310	52.600
	148,160					-14.0	1,492	79.081
	149,652					0.0	1,948	58.190
	151,600					-8.3	1,477	58.190
	153,077					0.0	3,673	46.000
	156,750					-6.9	2,700	46.000
	157,253	R	6,000	BTC				
	157,933			BCC				
	158,399			ECC				
	159,079			ETC	11,115			
	159,450					7.9	1,150	27.373
	160,600					-3.1	1,600	36.497
	162,200					2.5	1,200	31.542
	163,400					-2.3	1,750	34.524
	165,150					0.0	2,050	30.500
	167,200					8.0	1,000	30.500
	168,200					0.0	1,450	38.500
Vapi	168,900							
	169,650					-3.5	2,681	38.500
	170,194	L	6,000	BTC				
	170,874			BCC				
	172,331					0.0	3,669	29.000
	172,987			ECC				
	173,667			ETC	4,079			
	176,000					-3.0	1,000	29.000
	177,000					0.0	1,438	26.000
	177,745	R	8,000	BTC				
	178,365			BCC				
	178,438					3.0	2,784	26.000
	178,512			ECC				
	179,132			ETC	19,616			
	181,222					0.4	8,188	34.386
	189,410					-10.1	790	37.512
	190,200					0.0	1,245	29.500
	191,445					7.9	826	29.500



Name of Station	Chainage (m)	R/L	Radius (m)		Distance (m)	Gradient (‰)	Distance (m)	Gradient change point (m)
	192,270					0.0	1,524	36.000
	193,794					-7.1	1,410	36.000
	195,204					1.6	1,246	26.031
	196,450					0.0	4,700	27.990
	198,748	R	8,000	BTC				
	199,368			BCC				
	199,498			ECC				
	200,118			ETC	21,581			
	201,150					-2.0	1,025	28.050
	202,175					0.0	7,338	26.000
	209,513					5.5	1,087	26.000
	210,600					-5.5	2,148	31.980
	212,748					-0.2	2,002	20.165
	214,750					3.0	1,811	19.715
	216,561					0.0	4,045	25.147
Bilimora	217,300							
	220,606					2.0	794	25.147
	221,400					-0.6	6,150	26.736
	221,699	L	6,000	BTC				
	222,379			BCC				
	224,154			ECC				
	224,834			ETC	10,545			
	227,550					0.7	2,829	22.760
	230,380					-2.2	3,043	24.776
	233,422					6.0	1,695	18.058
	235,118					-1.4	3,232	28.230
	235,380	L	6,000	BTC				
	236,060			BCC				
	236,511			ECC				
	237,191			ETC	13,110			
	238,350					-0.8	7,132	23.611
	245,482					-0.5	2,519	17.564
	248,000					2.0	1,850	16.301
	249,850					0.0	1,324	20.000
	250,301	R	6,000	BTC				
	250,981			BCC				
	251,174					-1.9	1,576	20.000
	252,750					1.0	2,000	17.000
	253,371			ECC				
	254,051			ETC	12,003			
	254,750					-1.0	1,884	19.000

Name of Station	Chainage (m)	R/L	Radius (m)		Distance (m)	Gradient (‰)	Distance (m)	Gradient change point (m)
	256,634					0.7	5,781	17.206
	262,415					5.0	881	21.321
	263,296					0.0	5,404	25.728
Surat	264,450							
	266,054	L	8,000	BTC				
	266,674			BCC				
	267,082			ECC				
	267,702			ETC	2,384			
	268,700					0.8	1,335	25.728
	270,035					-0.3	4,803	26.863
	270,086	R	6,000	BTC				
	270,766			BCC				
	271,574			ECC				
	272,254			ETC	590			
	272,844	L	4,000	BTC				
	273,454			BCC				
	274,837					4.0	1,363	25.650
	275,196			ECC				
	275,806			ETC	1,819			
	276,200					0.0	700	31.101
	276,900					-3.0	1,059	31.101
	277,625	R	6,000	BTC				
	277,959					0.1	1,991	27.924
	278,305			BCC				
	278,728			ECC				
	279,408			ETC	7,498			
	279,950					-2.0	1,100	28.200
	281,050					0.0	4,308	26.000
	285,358					12.0	942	26.000
	286,300					-9.0	1,463	37.300
	286,906	R	6,000	BTC				
	287,586			BCC				
	287,763					-1.7	1,347	24.136
	289,109					0.0	3,674	21.867
	290,217			ECC				
	290,897			ETC	3,588			
	292,784					2.6	1,608	21.867
	294,391					0.0	2,125	26.000
	294,486	L	6,000	BTC				
	295,166			BCC				
	295,681			ECC				

Name of Station	Chainage (m)	R/L	Radius (m)		Distance (m)	Gradient (‰)	Distance (m)	Gradient change point (m)
	296,361			ETC	15,266			
	296,516					14.0	984	26.022
	297,500					-12.0	914	39.800
	298,414					-0.6	1,437	28.829
	299,851					-0.7	5,199	27.999
	305,050					0.0	2,300	24.593
	307,350					-2.0	1,122	24.497
	308,472					-0.2	4,128	22.252
	311,627	L	6,000	BTC				
	312,307			BCC				
	312,600					-2.8	1,200	21.350
	312,832			ECC				
	313,512			ETC	19,488			
	313,800					0.0	2,467	18.000
	316,267					12.0	1,233	18.000
	317,500					-12.0	858	32.800
	318,358					0.0	3,142	22.500
	321,500					-2.8	710	22.500
	322,210					0.0	2,486	20.493
Bharuch	323,060							
	324,696					3.0	2,054	20.493
	326,750					-4.0	818	26.656
	327,568					-1.0	5,151	23.385
	332,719					10.0	931	18.044
	333,000	R	6,000	BTC				
	333,650					-10.0	856	27.358
	333,680			BCC				
	334,506					-1.0	1,923	18.794
	335,261			ECC				
	335,941			ETC	25,377			
	336,430					0.5	3,647	16.870
	340,077					1.2	6,048	18.596
	346,124					0.0	5,782	26.000
	351,906					-0.5	6,462	26.000
	358,368					1.0	732	22.647
	359,100					-2.0	892	23.379
	359,992					0.3	10,684	21.594
	361,319	R	6,000	BTC				
	361,999			BCC				
	362,674			ECC				
	363,354			ETC	25,365			

Name of Station	Chainage (m)	R/L	Radius (m)		Distance (m)	Gradient (‰)	Distance (m)	Gradient change point (m)
	370,676					1.0	1,074	24.343
	371,750					0.0	1,200	25.417
	372,950					-1.9	943	25.363
	373,893					0.3	9,655	23.530
	383,549					12.0	1,401	25.987
	384,950					-12.0	1,400	42.800
	386,350					0.0	3,088	26.000
	388,719	L	3,000	BTC				
	389,229			BCC				
	389,438					13.0	1,692	26.000
	390,248			ECC				
	390,758			ETC	3,262			
	391,130					0.0	13,386	48.000
	394,020	R	8,000	BTC				
	394,110			BCC				
	394,218			ECC				
	394,308			ETC	1,940			
	396,248	L	1,200	BTC				
	396,278			BCC				
	396,450			ECC				
	396,480			ETC	868			
Vadodara	396,910							
	397,348	L	1,200	BTC				
	397,378			BCC				
	397,940			ECC				
	397,970			ETC	3,467			
	401,436	R	1,500	BTC				
	401,796			BCC				
	403,310			ECC				
	403,670			ETC	350			
	404,020	L	1,600	BTC				
	404,380			BCC				
	404,516					-8.0	1,374	48.000
	405,890					8.6	1,154	37.009
	406,257			ECC				
	406,617			ETC	5,003			
	407,044					-10.4	1,030	46.933
	408,074					7.2	1,411	36.183
	409,485					-5.0	1,687	46.409
	411,173					0.0	2,427	37.972
	411,621	L	6,000	BTC				

Name of Station	Chainage (m)	R/L	Radius (m)		Distance (m)	Gradient (‰)	Distance (m)	Gradient change point (m)
	412,301			BCC				
	412,565			ECC				
	413,245			ETC	4,631			
	413,600					4.3	1,400	38.027
	415,000					2.1	1,050	43.996
	416,050					-6.0	1,693	46.159
	417,743					0.0	931	36.000
	417,877	R	6,000	BTC				
	418,557			BCC				
	418,674					6.0	2,026	36.000
	419,679			ECC				
	420,359			ETC	5,422			
	420,700					-2.0	1,100	48.200
	421,800					0.0	9,450	46.000
	425,780	L	8,000	BTC				
	426,400			BCC				
	426,528			ECC				
	427,148			ETC	13,078			
	431,250					2.0	1,000	46.000
	432,250					0.7	2,350	48.000
	434,600					-1.1	3,454	49.700
	438,054					0.0	1,203	46.000
	439,256					2.0	855	46.000
	440,111					-0.5	4,889	47.709
	440,226	L	6,000	BTC				
	440,906			BCC				
	442,946			ECC				
	443,626			ETC	7,430			
	445,000					-4.0	1,300	45.173
	446,300					0.0	1,610	40.000
Anand/Nadiad	447,110							
	447,910					-0.6	3,090	40.000
	451,000					0.5	4,050	38.000
	451,056	R	6,000	BTC				
	451,736			BCC				
	453,984			ECC				
	454,664			ETC	21,136			
	455,050					-3.0	1,333	40.000
	456,383					0.0	1,346	36.000
	457,729					3.0	771	36.000
	458,500					-3.0	771	38.312



Name of Station	Chainage (m)	R/L	Radius (m)		Distance (m)	Gradient (‰)	Distance (m)	Gradient change point (m)
	459,271					0.0	2,009	36.000
	461,280					3.0	1,720	36.000
	463,000					-4.0	2,643	41.160
	465,643					0.7	2,869	30.588
	468,512					4.0	2,238	32.537
	470,750					-0.6	2,350	41.507
	473,100					0.3	3,500	40.123
	475,799	R	8,000	BTC				
	476,419			BCC				
	476,600					-0.5	8,439	41.000
	476,642			ECC				
	477,262			ETC	10,229			
	485,039					8.0	3,961	36.815
	487,491	R	6,000	BTC				
	488,171			BCC				
	489,000					0.0	17,290	68.500
	489,379			ECC				
	490,059			ETC	475			
	490,534	L	6,000	BTC				
	491,214			BCC				
	491,597			ECC				
	492,277			ETC	281			
	492,558	R	10,000	BTC				
	492,658			BCC				
	492,758			ECC				
	492,858			ETC	2,422			
	495,280	R	12,000	BTC				
	495,310			BCC				
	495,411			ECC				
	495,441			ETC	2,340			
	497,781	L	3,500	BTC				
	497,861			BCC				
	497,978			ECC				
	498,058			ETC	213			
	498,271	R	3,500	BTC				
	498,351			BCC				
	498,452			ECC				
	498,532			ETC	173			
	498,705	R	1,000	BTC				
	498,765			BCC				
	499,085			ECC				

Name of Station	Chainage (m)	R/L	Radius (m)		Distance (m)	Gradient (‰)	Distance (m)	Gradient change point (m)
	499,145			ETC	1,217			
Ahmedabad	499,750							
	500,362	L	1,000	BTC				
	500,422			BCC				
	500,885			ECC				
	500,945			ETC	1,626			
	502,572	R	1,200	BTC				
	502,902			BCC				
	503,054			ECC				
	503,384			ETC	1,790			
	505,174	L	1,200	BTC				
	505,254			BCC				
Sabarmati	505,370							
	505,480			ECC				
	505,560			ETC	568			
	506,128	L	1,200	BTC				
	506,208			BCC				
	506,290					-5.0	1,630	68.500
	506,373			ECC				
	506,453			ETC	1,467			
	507,920					0.0		60.352
	507,920							

Note) BTC: Beginning of Transition Curve, BCC: Beginning of Circular Curve, ETC: End of Transition Curve, ECC: End of Circular Curve

Source: Study Team

#### 4.7.4 Preliminary Survey of Alignment

##### (1) Introduction

The alignment proposed by study team was accepted in JMC held on 21th November 2015. Preliminary survey is being done by elaborating the map scale from 1:50,000 to 1:10,000 for the purpose of fixing the alignment.

The Ministry of Railways in November 2015 decided to entrust the work of implementation of High Speed Rail Project (HSR) to Rail Vikas Nigam Limited (RVNL)/ High Speed Rail Corporation of India Limited (HSRC).

After couple of joint meetings with Ministry of Railways, RVNL and JICA the Study team came out with a detailed Preliminary Survey Plan to be carried out by Study Team.

##### (2) Objectives

The main objective to carry out the Preliminary Survey is fixing the route corridor with all stations locations and fixing the initial Alignment at the scale of 1:10,000.

##### (3) Comparison of five alternative station locations near Vadodara existing railway station

As shown in Figure 4.7-102, five alternative station location plans were considered near Vadodara existing railway station. In the case-1 and 2, HSR station juxtaposed to Vadodara existing railway station on west side. In the case-3, HSR station located at northeast side 1 km away from Vadodara existing railway station. In the case-4, HSR station located at south side 1.6 km away from Vadodara existing railway station. In the case-5, HSR station located at south side 3.0 km away from Vadodara existing railway station and juxtaposed to Vishwamitri existing railway station, which is not main station.

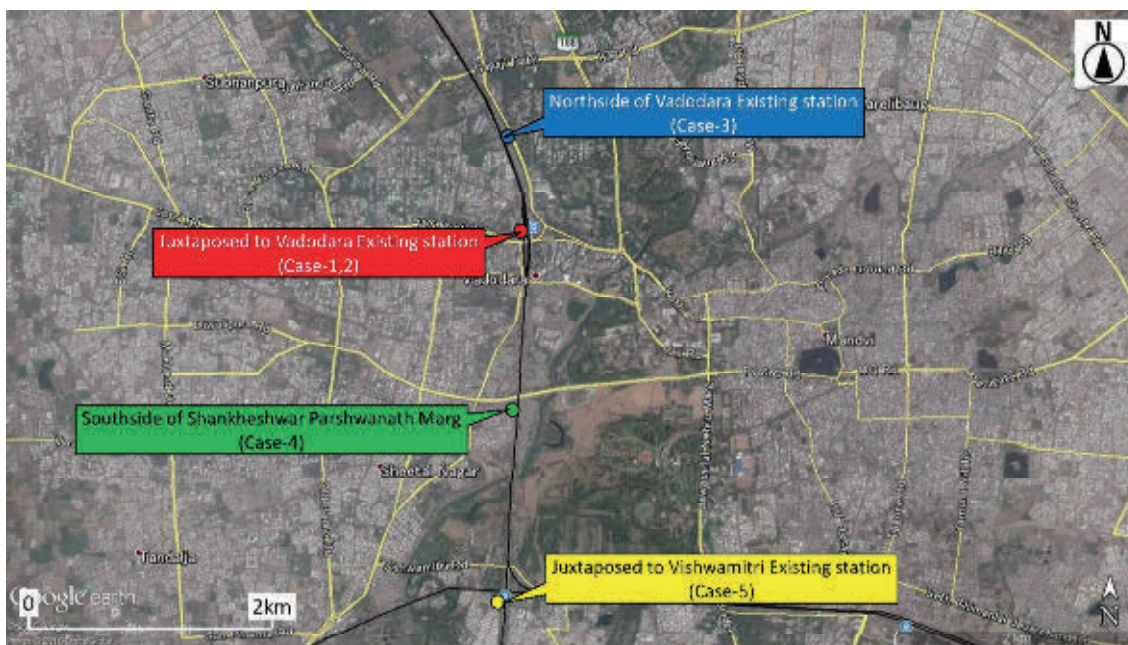

Source: Google Earth, study Team

Figure 4.7-102 Five Alternative Station Location Plans near Vadodara Existing Railway Station

Table 4.7-21 and Table 4.7-22 show comparison of five alternative station location plans. Based on several viewpoints such as connectivity with existing railway station, land acquisition, difficulty of construction and traffic potential, these station locations were evaluated. In Table 4.7-21 and Table 4.7-22, red text indicates advantages and blue text indicates disadvantages.

Main points of evaluation are as follows:

- In the viewpoint of connectivity with existing railway station and traffic potential, case-1 and case-2 would be recommended due to good connectivity with Vadodara existing railway station and being expected to transfer from Vadodara existing railway station.
- In the viewpoint of land acquisition, compared with case-1 and case-2, case-1 would be recommended because dismantling high-rise buildings will be needed in case-2.
- In the viewpoint of difficulty of construction, case-2 is a little easier than case-1 due to less impacts on existing railway facilities.

On overall evaluation, case-1 would be more desirable than other alternative station location plans.

Table 4.7-21 Comparison Table (Case-1, 2 & 3) of Five Alternative Station Location Plans near Vadodara Existing Railway Station

	CASE-1	CASE-2	CASE-3
Station location	Juxtaposed to Vadodara Existing Rly Sta. (elevated)	Juxtaposed to Vadodara Existing Rly Sta. (elevated)	Northeast side 1 km away from Vadodara Existing Rly Sta. (elevated)
Connectivity with Existing Railway	Good connectivity with existing railway	Good connectivity with existing railway	It's hard to connecting with existing railway
Land acquisition	Partial land of Indian railway. Private land acquisition will be needed	Partial land of Indian railway. Dismantling high-rise buildings will be needed	Partial land of Indian railway. Private land acquisition will be needed in east side of the station
Difficulty of Construction	A Little harder than CASE-2 due to some impacts on existing railway facilities	A Little easier than CASE-1 due to less impacts on existing railway facilities	A Little hard to construct
Traffic Potential	Huge. Expected to transfer from Existing Rly Sta.	Huge. Expected to transfer from Existing Rly Sta.	Small. Difficult to transfer from Existing Rly Sta.
Total evaluation	✓✓✓ Remodeling existing railway facilities will be needed	✓✓ Dismantling high-rise buildings will be needed	✓

Source: Study Team

Table 4.7-22 Comparison Table (Case-4 & 5) of Five Alternative Station Location Plans near Vadodara Existing Railway Station

	CASE-4	CASE-5
Station location	South side 1.6 km away from Vadodara Existing Rly Sta. (elevated)	South side 3.0 km away from Vadodara Existing Rly Sta. (elevated)
Connectivity with Existing Railway	It's hard to connecting with existing railway	Connectivity with Vishwamitri existing railway (not main station)
Land acquisition	Partial land of Indian railway. Private land acquisition will be needed	Partial land of Indian railway. Private land acquisition will be needed
Difficulty of Construction	Easy to construct	A Little easy to construct
Traffic Potential	Small. Difficult to transfer from Existing RLY Sta.	Small. Connected to not main Station
Total evaluation	✓	✓

Source: Study Team

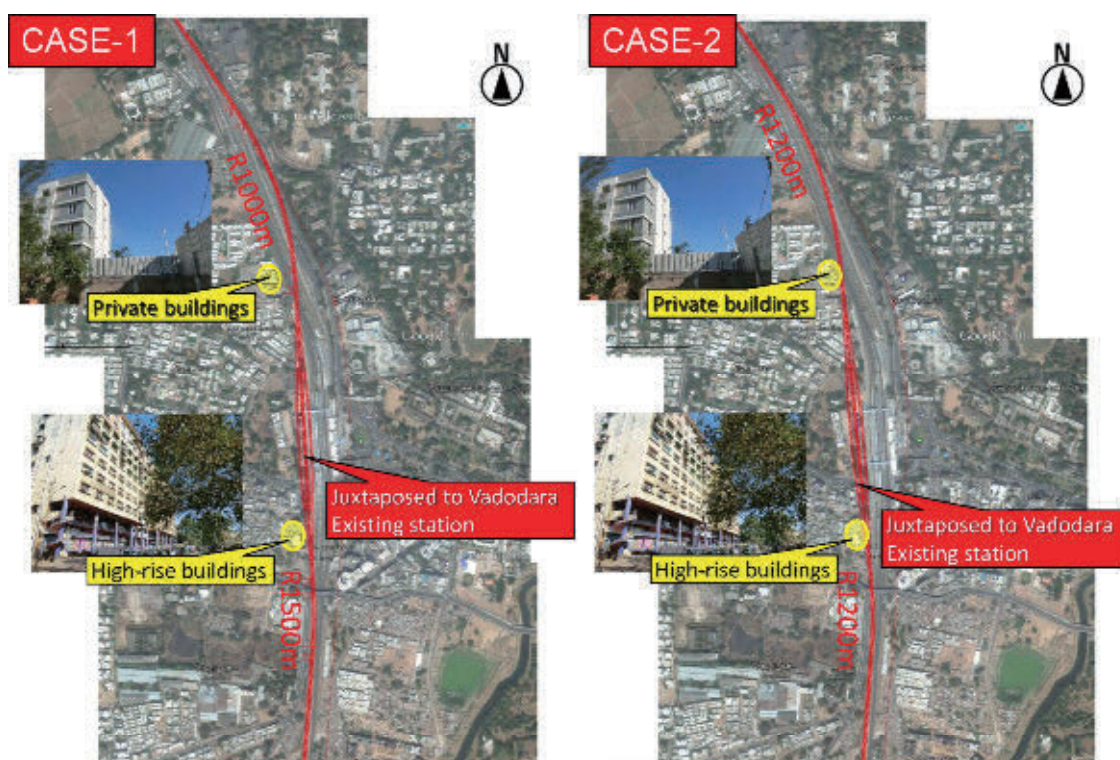

Source: Google Earth, study Team

Figure 4.7-103 Alternative Station Location Plans (Case-1 & 2) near Vadodara Existing Railway Station



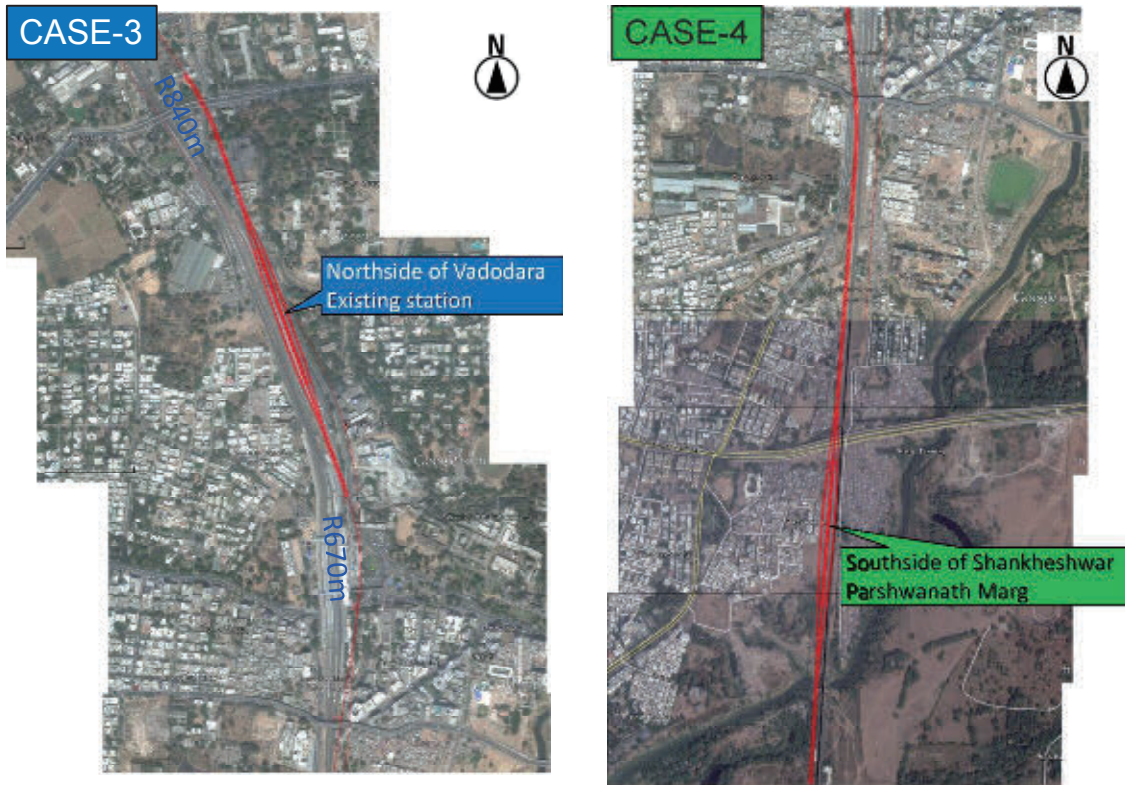

Source: Google Earth, study Team

Figure 4.7-104 Alternative Station Location Plans (Case-3 & 4) near Vadodara Existing Railway Station



Source: Google Earth, study Team

Figure 4.7-105 Alternative Station Location Plans (Case-5) near Vadodara Existing Railway Station

(4) Connection to Vadodara existing railway station

HSR Vadodara station will be connected to the existing railway station as shown in Figure 4.7-106.

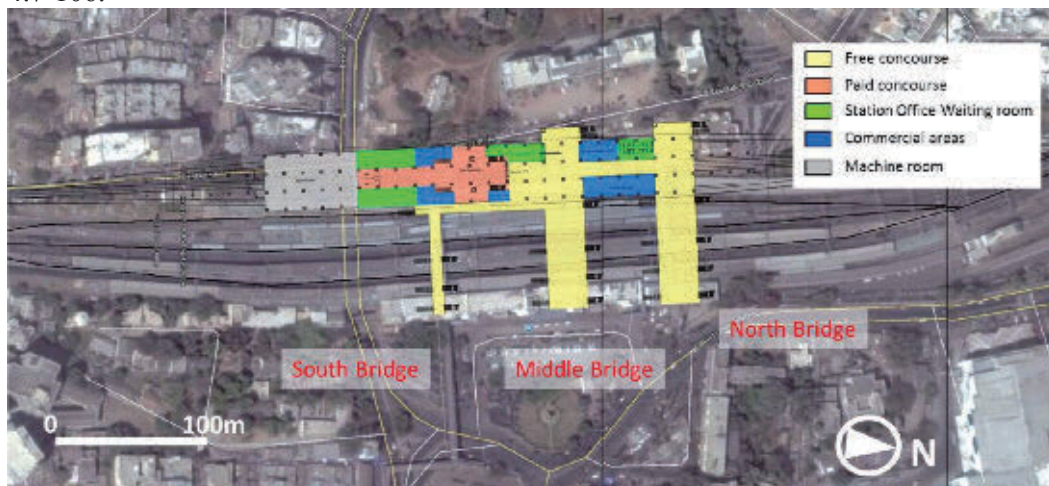

Source: Google Earth, JICA Study Team

Figure 4.7-106 Connection between HSR and Existing Station in Vadodara

The idea is to make 3 parallel passenger bridges to supply a convenient accessibility between the two stations. Since there are present passenger bridges at the existing station, the renovation plan is decided as follows:

- South: Utilize the existing bridge
- Middle: Construct a new bridge
- North: Double size the existing bridge.

The reason to create a new passenger bridge between the existing south and north bridge is because it is better to create the main access route to lead the passengers directly to the core of the HSR station. This is the reason why the width of the new bridge is larger than the existing bridges. Since the location of the paid concourse is fixed due to the platform layout, the core of the station could be placed rather on the south or north of the paid concourse. The core of the station is decided to be located at the north side of the paid concourse so that the existing north bridge could also be connected easily to the core area of the HSR station. The layout of the station and the connecting bridges are shown in Figure 4.7-107.



Source: JICA Study Team

Figure 4.7-107 Layout Plan of the Station and Connection Bridges at Vadodara Station



(5) Comparison of three alternative station locations near Ahmedabad existing railway station

As shown in Figure 4.7-108, three alternative station location plans were considered near Ahmedabad existing railway station. In the case-1, HSR station juxtaposed to Ahmedabad existing railway station on east side and the HSR route pass between existing main tracks and storage tracks on south side of existing railway station with two curves ( $R_1=1000$  m and  $R_2=8000$  m). In the case -2, HSR station juxtaposed to Ahmedabad existing railway station on east side and the HSR route pass through east side of storage tracks on south side of existing railway station with four curves ( $R_1=400$  m,  $R_2=1000$  m,  $R_3=1000$  m and  $R_4=2000$ m). In the case -3, HSR station almost juxtaposed to Ahmedabad existing railway station on east side and the HSR route pass through east side of storage tracks on south side of existing railway station with three curves ( $R_1=1000$  m,  $R_2=1000$  m and  $R_3=2000$  m).

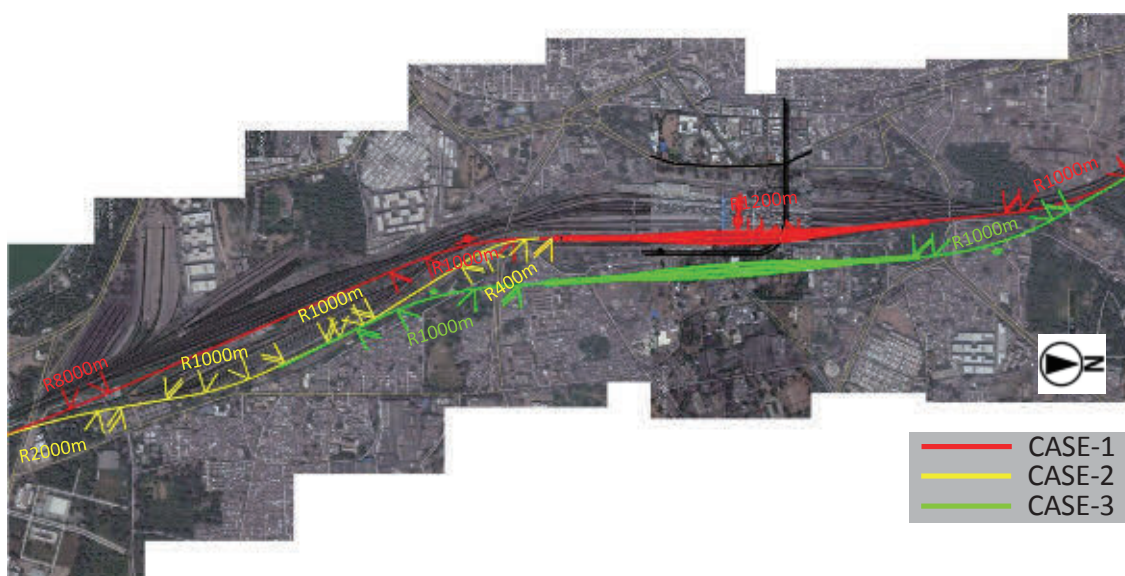

Source: Google Earth, study Team

Figure 4.7-108 Three Alternative Station Location Plans near Ahmedabad Existing Railway Station

Table 4.7-23 shows comparison of three alternative station location plans. Based on several viewpoints such as connectivity with mass transport system, land acquisition, difficulty of construction, curve features and traffic potential, these station locations were evaluated. In Table 4.7-23, red text indicates advantages and blue text indicates disadvantages.

Main points of evaluation are as follows:

- In the viewpoint of connectivity with mass transport system and traffic potential, there is not a big difference among them.
- In the viewpoint of land acquisition, there is not a difference among case-1 and case-2, in case-3, movement of many private buildings would be needed due to passing through residential areas.
- In the viewpoint of difficulty of construction, case-2 is a little easier than case-1 due to less impacts on existing railway facilities.
- Curve features of case-1 will be more preferable than those of case-2 even before and after station.

On overall evaluation, case-1 would be more desirable than other alternative station location plans.

Table 4.7-23 Comparison Table of Three Alternative Station Location Plans near Ahmedabad Existing Railway Station

	CASE-1	CASE-2	CASE-3
Station location	Juxtaposed to Ahmedabad Existing Rly Sta. (elevated)	Juxtaposed to Ahmedabad Existing Rly Sta. (elevated)	Almost juxtaposed to Ahmedabad Existing Rly Sta. (elevated)
Connectivity with Mass Transport system	Good connectivity with existing railway and metro	Good connectivity with existing railway and metro	Good connectivity with existing railway and metro
Land acquisition	Land of Indian railway	Land of Indian railway	Partial land of Indian railway. Movement of many private buildings
Difficulty of Construction	A Little hard to construct due to some impacts on existing railway facilities	A Little easier than CASE-1 due to less impacts on existing railway facilities	A little easier than CASE-1 and CASE-2
Curve features	Simple curves	Complex curves, minimum radius:R400 m	Simple curves
Traffic Potential	Huge. Expected to transfer from Existing Rly Sta.	Huge. Expected to transfer from Existing Rly Sta.	Huge. Expected to transfer from Existing Rly Sta.
Total evaluation	✓✓✓ Curve features will be more preferable than CASE-2 even before and after station	✓✓	✓

Source: Study Team

(6) Connection to Ahmedabad existing railway station

HSR Ahmedabad station will be connected to the existing railway station as shown in Figure 4.7-109.



Source: Google Earth, JICA Study Team

Figure 4.7-109 Connection between HSR and Existing Station in Ahmedabad

The idea is to make 3 parallel passenger bridges to supply a convenient accessibility between the two stations. Since there are present passenger bridges at the existing station, the renovation plan is decided as follows:

- South: Utilize the existing bridge and connect with a corridor
- Middle: Double size the existing bridge
- North: Utilize the existing bridge

As same as in the case of Vadodara station, the main access route is made to lead the passengers directly to the core of the Ahmedabad HSR station. Since the location of the paid concourse is fixed due to the platform layout, the core of the station could be placed rather on the south or north of the paid concourse. The core of the station is decided to be located at the south side of the paid concourse so that the existing south bridge could also be connected easily to the core area of the HSR station. The layout of the station and the connecting bridges are shown in Figure 4.7-110.

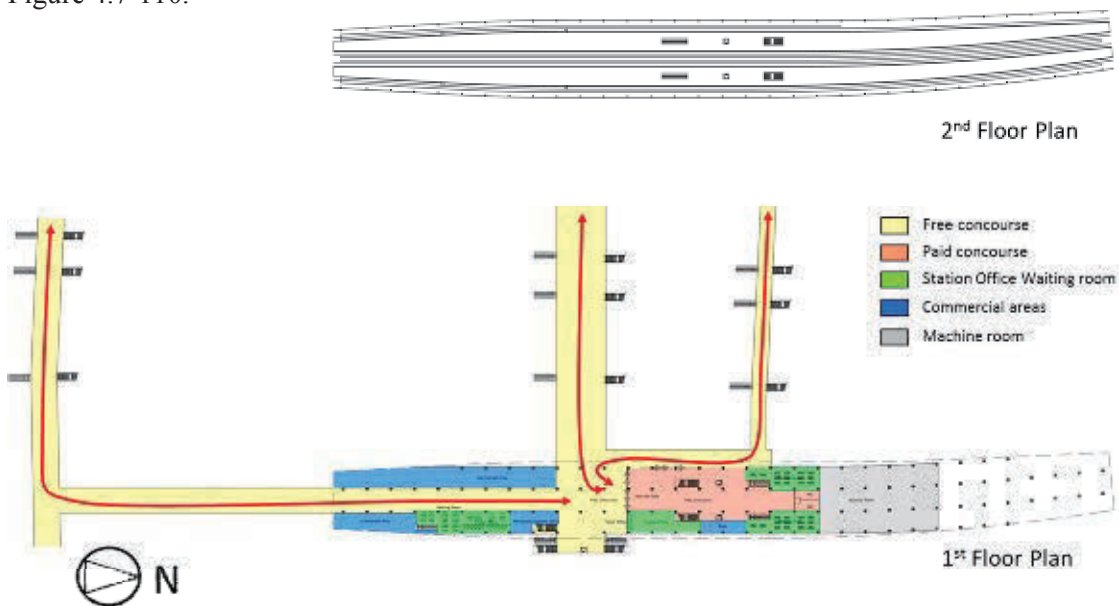

Source: JICA Study Team

Figure 4.7-110 Layout Plan of the Station and Connection Bridges at Ahmedabad Station



(7) Fixing the alignment with all station locations cooperating with RVNL/HSRC

The study team carried out fixing the alignment with all station locations cooperating with RVNL/HSRC.

Main contents of changing alignment and station locations are as follows:

- To avoid high rise buildings under construction and new development areas for residential.
- To avoid not only large villages and ponds but also small villages and ponds.
- To reduce the number of curves.
- To reconsider intermediate station locations in the viewpoint of future development.
- To reconsider how to cross with planned DFC and planned Expressway.

1) Main revised point

As shown in Figure 4.7-111, there are 14 points as main revised points cooperating with RVNL/HSRC.

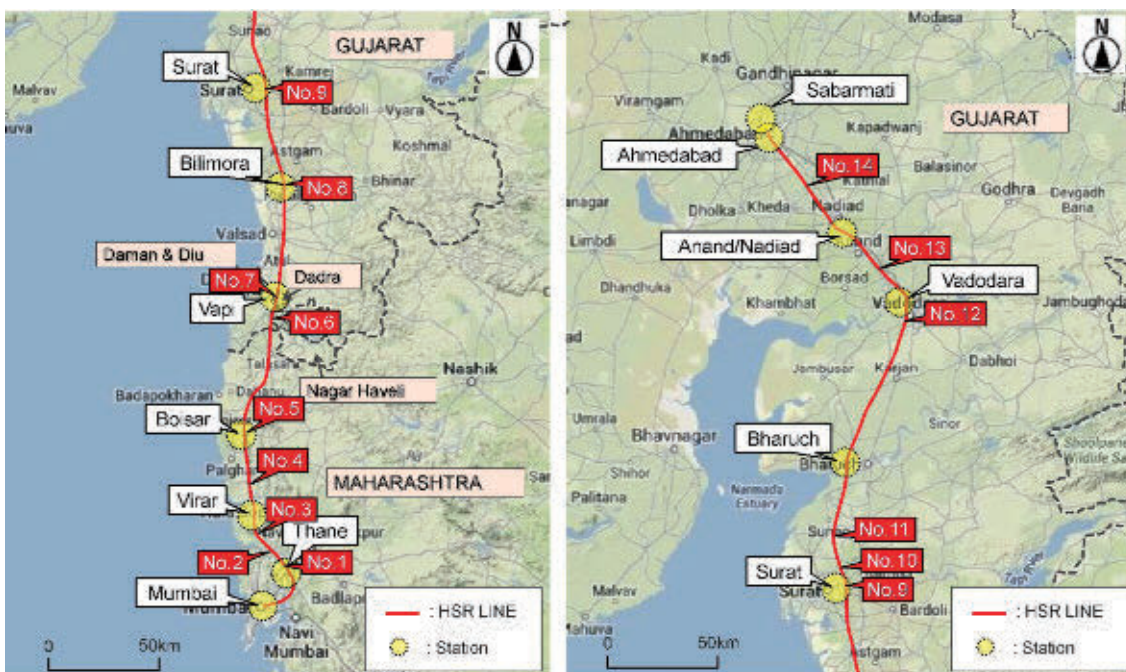

Source: Google Map, study Team

Figure 4.7-111 Map of Main Revised Points

2) Detailed description

a) Northwest side of Thane HSR station

Main points of revised planning are as follows:

- Revised HSR route avoided large industrial warehouses at Gundavali and industrial warehouses at Purna with curve radius of 6,000 m. However, because the route could not avoid industrial warehouses at Rajlaxmi Complex, resettlement of these warehouses would be needed.

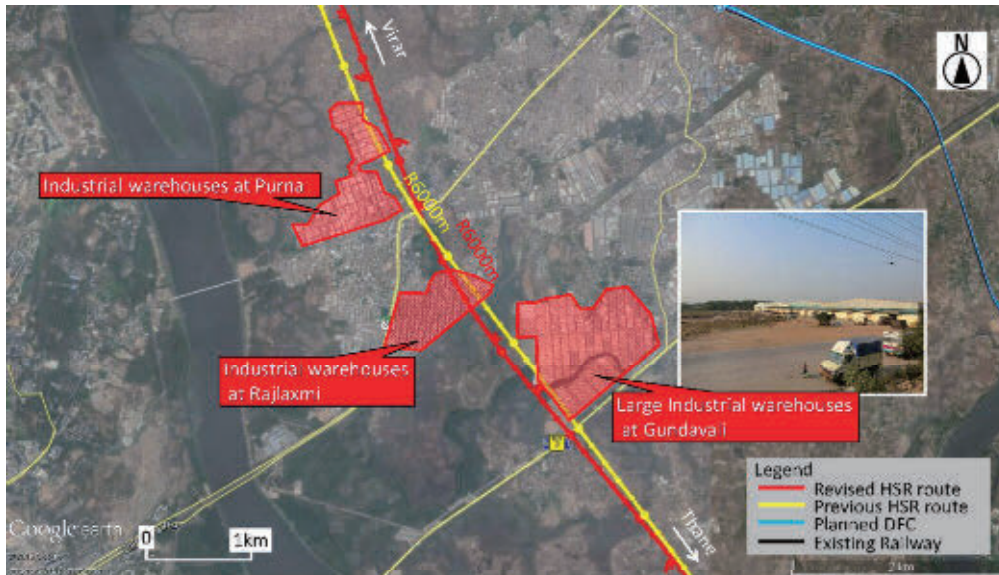

Source: Google Earth, study Team

Figure 4.7-112 Difference between Previous Route and Revised Route at No.1 Point

b) Between Sanjay Gandhi National Park and Tungareshwar Wildlife Sanctuary

Main points of revised planning are as follows:

- Previous HSR route adopted reverse curve with radius of 4,000 m and 6,000 m. Therefore, in this section of R 4,000 m, maximum train speed was 300 km/h.
- Revised HSR route adopted reverse curve with radii of 6,000 m and 6,000 m by passing through nearby Ulhas River. Therefore, in this section, maximum train speed has become possible to 350 km/h in the future.



Source: Google Earth, study Team

Figure 4.7-113 Difference between Previous Route and Revised Route at No.2 Point



c) South of Virar

Main points of revised planning are as follows:

- Previous HSR route cannot avoid high-rise buildings under construction. One year ago, there were not these buildings.
- Revised HSR route has become possible to avoid high-rise buildings under construction by adopting curve radius of 4,000 m (maximum train speed is 300 km/h).
- Revised HSR route has become possible to cross with Expressway by larger angle, compared with previous HSR route.



Source: Google Earth, study Team

Figure 4.7-114 Difference between Previous Route and Revised Route at No.3 Point

d) Between Virar and Boisar

Main points of revised planning are as follows:

- Revised HSR route can pass through almost center of mountains of reserved forest avoiding the valley between mountains, compared with previous HSR route.

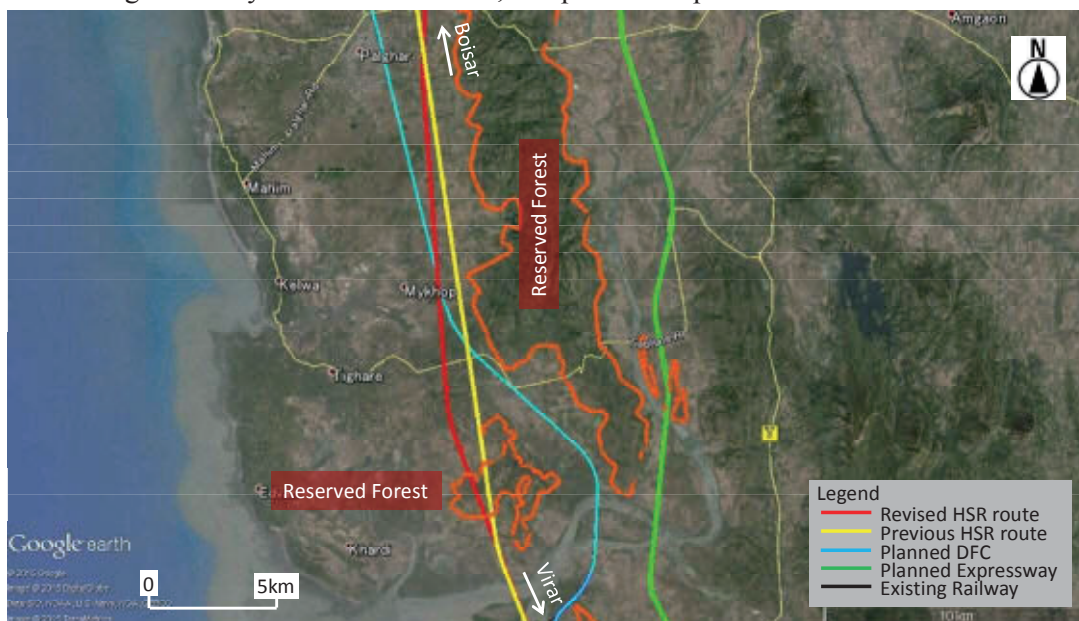

Source: Google Earth, study Team

Figure 4.7-115 Difference between Previous Route and Revised Route at No.4 Point

e) Before and after Boisar HSR station

Main points of revised planning are as follows:

- Revised HSR route can reduce the number of curves and the straight length becomes approx. 27 km, compared with previous HSR route.
- Revised HSR route can reduce the total length of passing through reserved forest; however the revised station location is approx. 2 km away from previous station location toward outside of city.

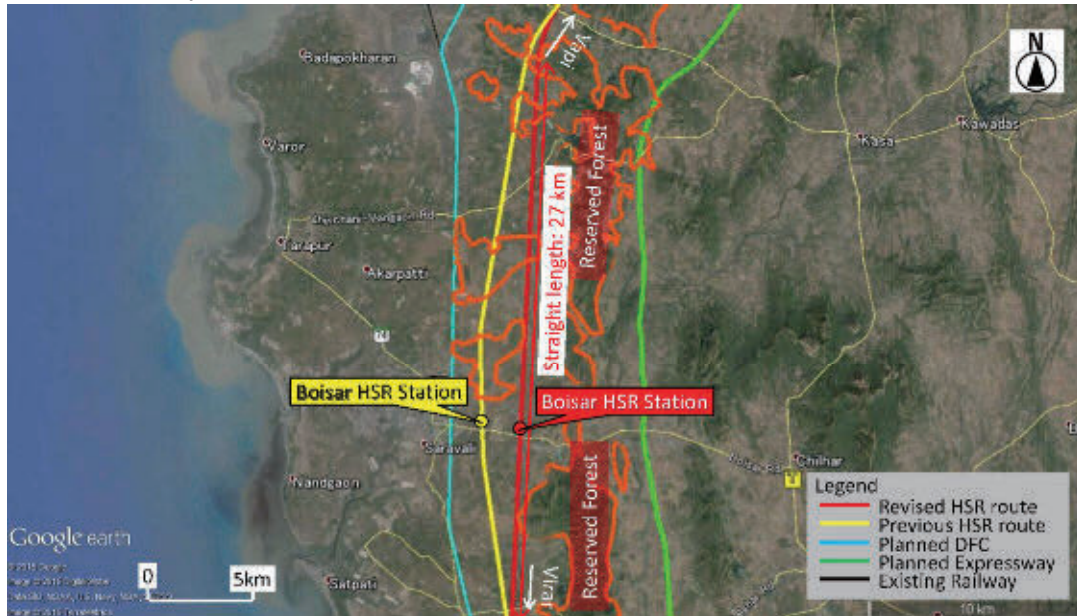

Source: Google Earth, study Team

Figure 4.7-116 Difference between Previous Route and Revised Route at No.5 Point

f) Between Boisar and Vapi

Main points of revised planning are as follows:

- Revised HSR route can reduce the number of curves compared with previous HSR route and the straight length becomes approx. 21 km.

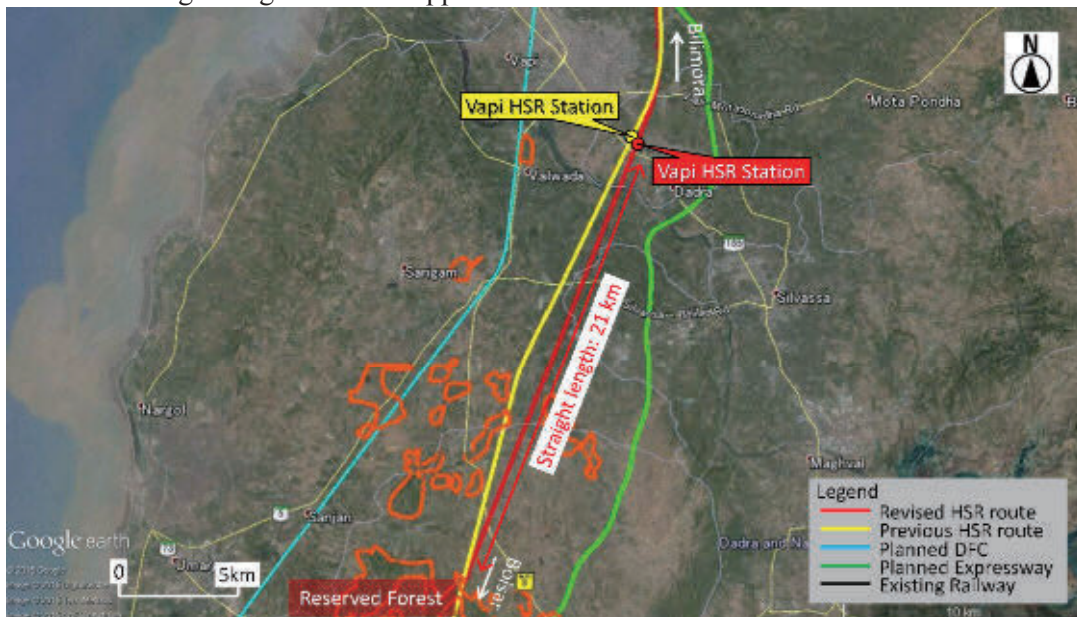

Source: Google Earth, study Team

Figure 4.7-117 Difference between Previous Route and Revised Route at No.6 Point



g) Near Vapi HSR station

Main points of revised planning are as follows:

- Previous HSR route cannot avoid new high-rise buildings. One year ago, there were not these buildings.
- Revised station location located at south side of SH No.185, there are no big residential buildings in the area at this moment.



Source: Google Earth, study Team

Figure 4.7-118 Difference between Previous Route and Revised Route at No.7 Point

h) Before and after Bilimora HSR station

Main points of revised planning are as follows:

- Previous HSR route cannot avoid these buildings under construction. One year ago, there were not these buildings.
- Revised station location located at south side of SH No.15, there are no big residential buildings in the area at this moment.

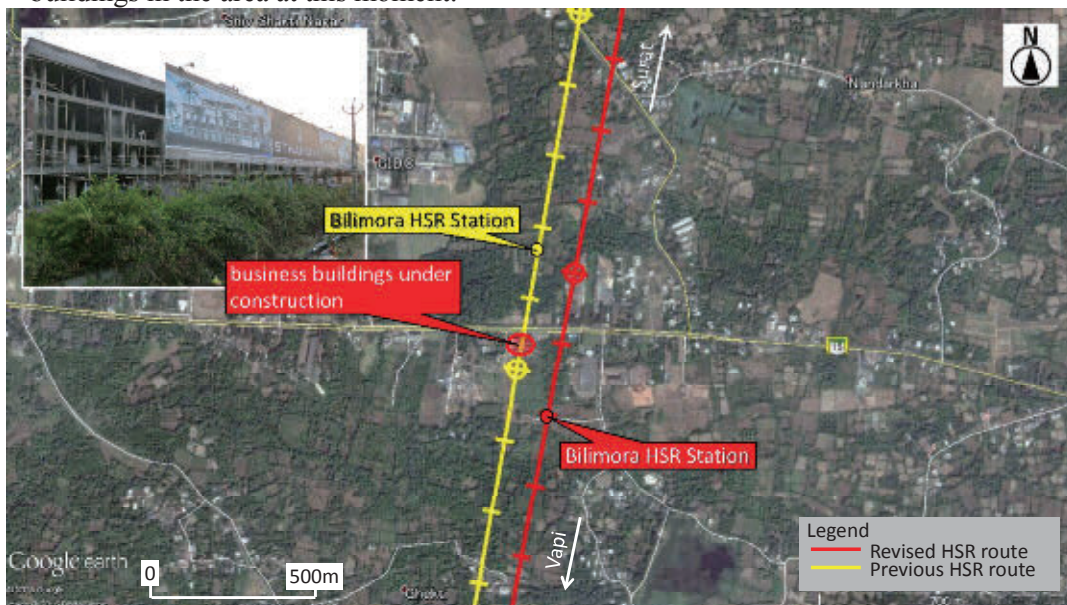

Source: Google Earth, study Team

Figure 4.7-119 Difference between Previous Route and Revised Route at No.8 Point



i) Before and after Surat HSR station

Main points of revised planning are as follows:

- Revised HSR route can reduce the number of curves compared with previous HSR route and the straight length becomes approx. 16 km as shown in Figure 4.7-120.
- Revised HSR route now made possible to avoid a big pond and resort houses as shown in Figure 4.7-121.

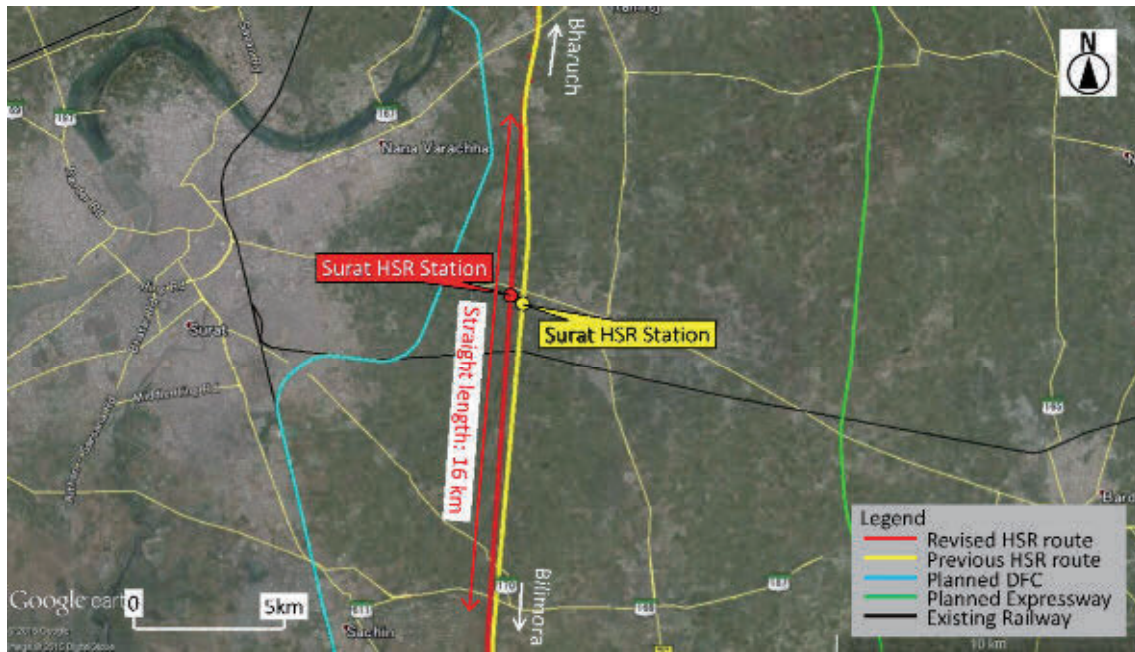

Source: Google Earth, study Team

Figure 4.7-120 Difference between Previous Route and Revised Route at No.9 Point

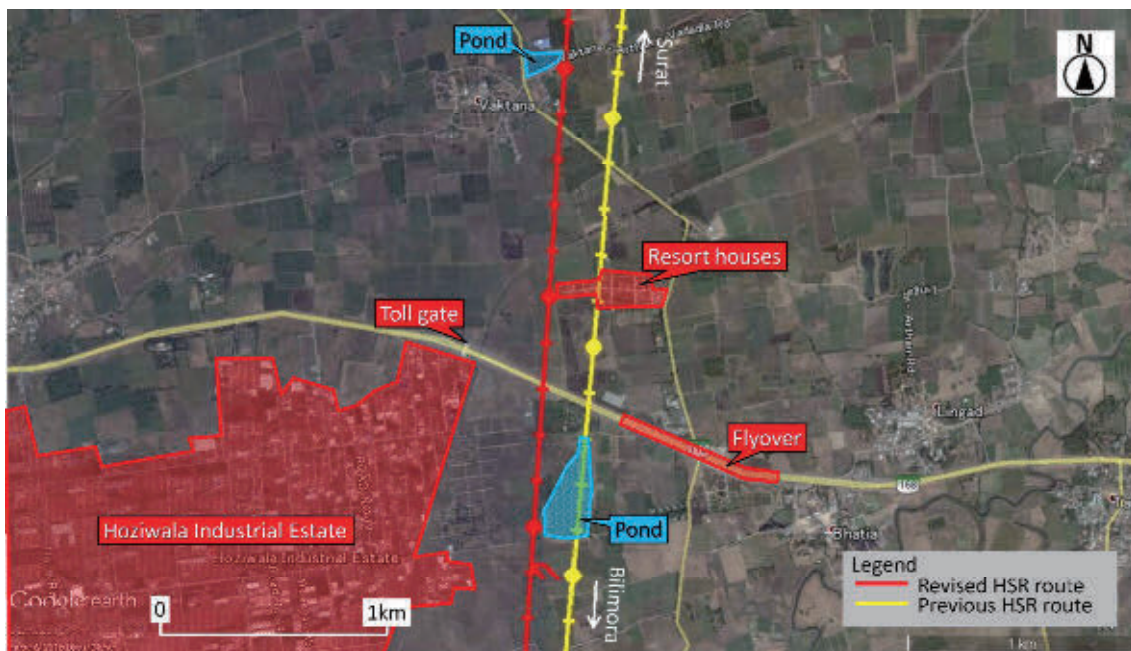

Source: Google Earth, study Team

Figure 4.7-121 Difference between Previous Route and Revised Route at No.9 Point



j) Between Surat and Bharuch

Main points of revised planning are as follows:

- Revised HSR route can reduce the number of curves compared with previous HSR route and the straight length becomes approx. 11 km. However, the resettlement of residential houses would be needed at Kathor on north side of Tapi River as shown in Figure 4.7-122.
- Revised HSR route has now made possible to avoid a new developing area for residential as shown in Figure 4.7-123.

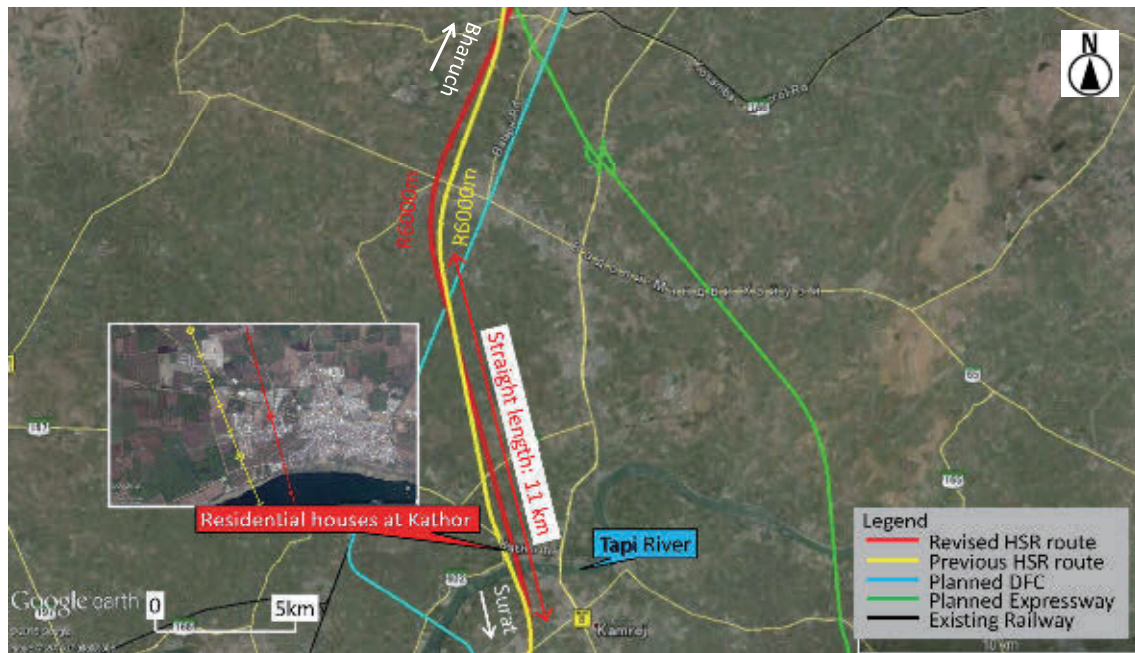

Source: Google Earth, study Team

Figure 4.7-122 Difference between Previous Route and Revised Route at No.10 Point

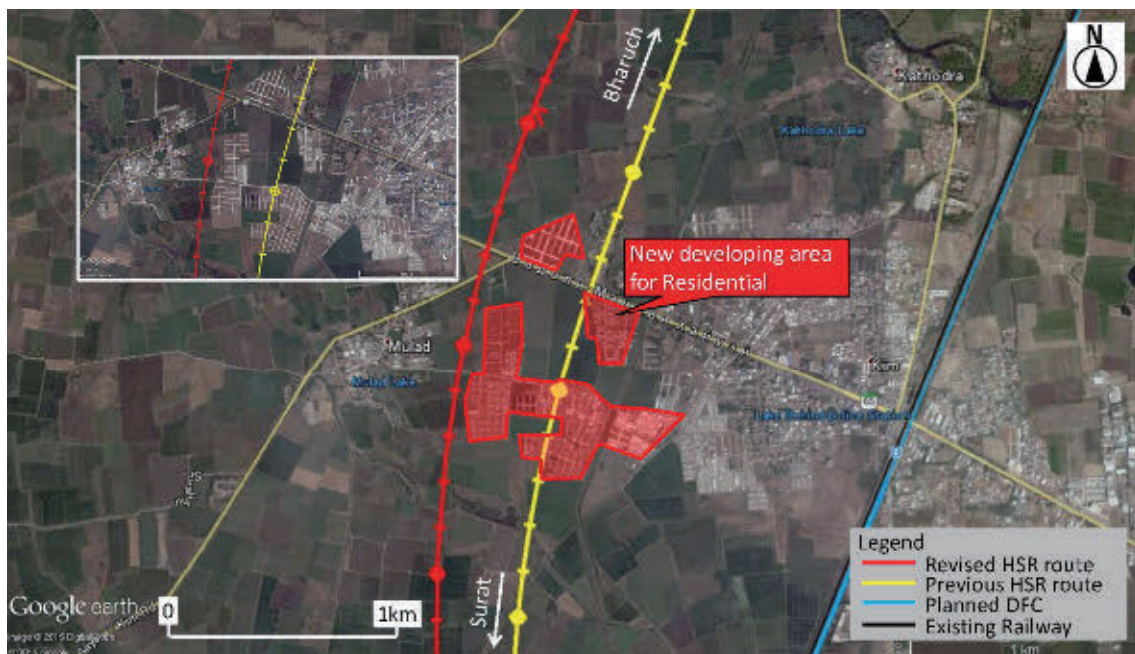

Source: Google Earth, study Team

Figure 4.7-123 Difference between Previous Route and Revised Route at No.11 Point



k) Approach to South Vadodara

Main points of revised planning are as follows:

- Revised HSR route has now made possible to adopt curve radius of R 6,000 m instead of increasing the number of crossing with a meandering small river.

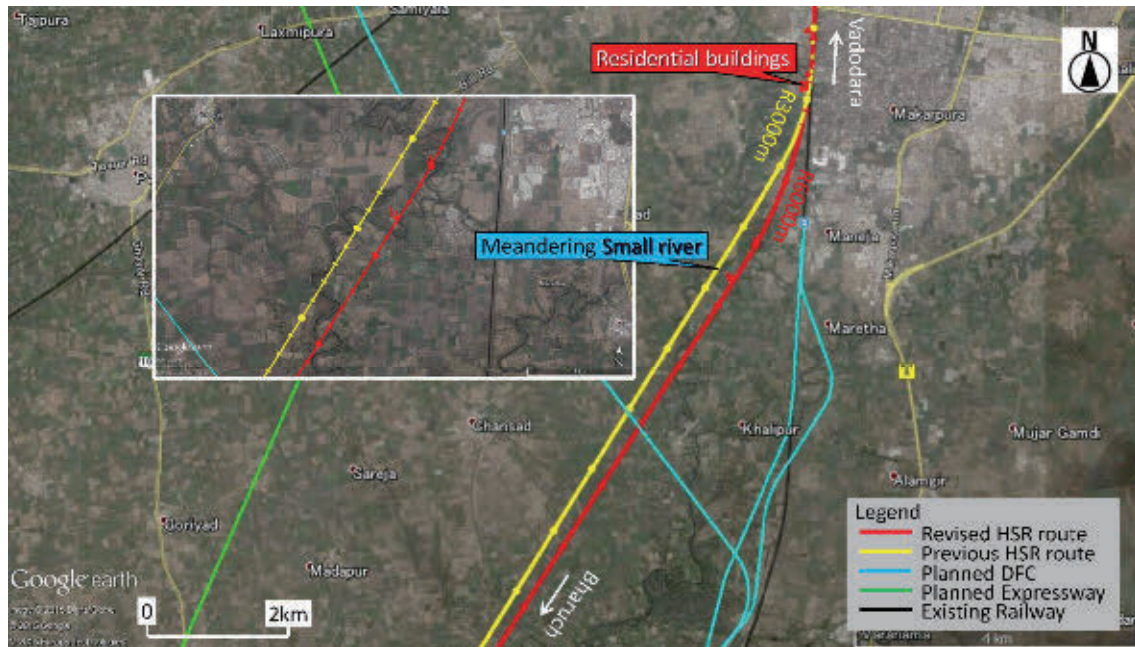

Source: Google Earth, study Team

Figure 4.7-124 Difference between Previous Route and Revised Route at No.12 Point

l) Between Vadodara and Anand/Nadiad

Main points of revised planning are as follows:

- Revised HSR route has now made possible to avoid a Navdurga Industrial Park by changing inter-angle point a little.

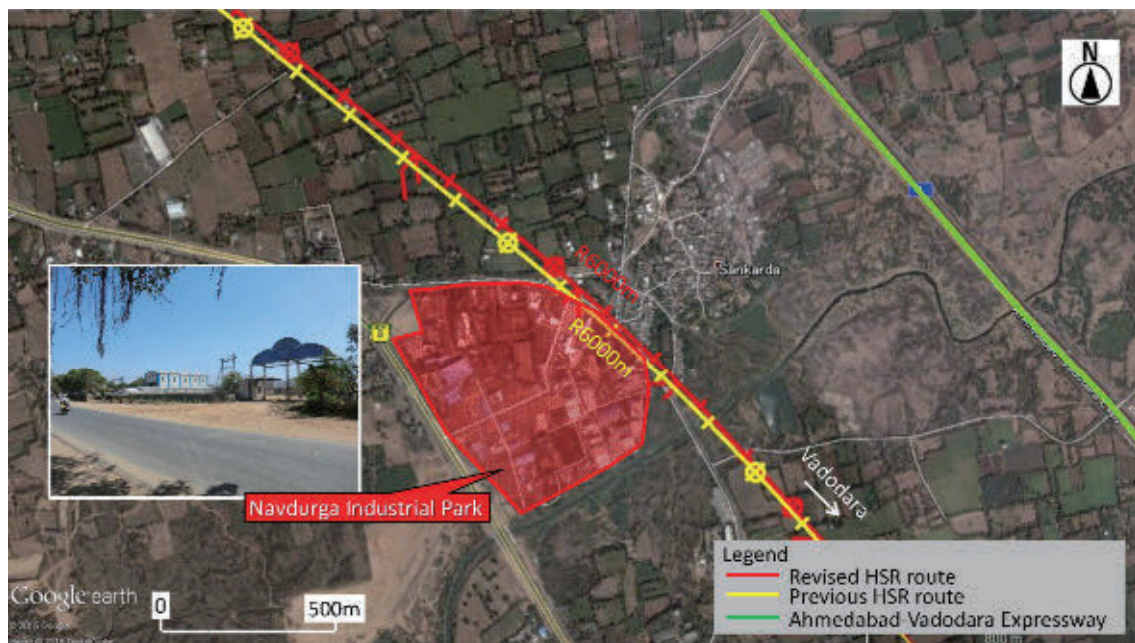

Source: Google Earth, study Team

Figure 4.7-125 Difference between Previous Route and Revised Route at No.13 Point

m) Between Anand/Nadiad and Ahmedabad

Main points of revised planning are as follows:

- Revised HSR route can reduce the number of curves compared with previous HSR route and the straight length becomes approx. 30 km.



Source: Google Earth, study Team

Figure 4.7-126 Difference between Previous Route and Revised Route at No.14 Point

(8) Revised HSR station km post and length

Table 4.7-24 shows revised HSR station km post and length. Red characters indicate the length was increased and blue characters indicate the length was decreased. As the result, total length between Mumbai HSR station and Sabarmati HSR station has become 505.75 km from 505.37 km.

Table 4.7-24 Revised Station km Post and Length

No.	Proposed station	Total Length (km)	Station Interval (km)
12	Sabarmati	505.75 (+0.38)	
11	Ahmedabad	500.19 (+0.44)	5.56 (-0.06)
10	Anand/Nadiad	447.38 (+0.27)	52.81 (+0.17)
9	Vadodara	397.06 (+0.15)	50.32 (+0.12)
8	Bharuch	323.11 (+0.05)	73.95 (+0.10)
7	Surat	264.58 (+0.13)	58.53 (-0.08)
6	Bilimora	216.58 (-0.72)	48.00 (+0.85)
5	Vapi	167.94 (-0.96)	48.64 (+0.24)
4	Boisar	104.26 (-0.09)	63.68 (-0.87)
3	Virar	65.17 (+0.25)	39.09 (-0.34)
2	Thane	27.95 (+0.03)	37.22 (+0.22)
1	Mumbai	0.00	27.95 (+0.03)

Source: Study Team



(9) Geometry data

Table 4.7-25 shows the geometry data of revised HSR route.

**Table 4.7-25 Geometry Data of Revised HSR Route**

Sl. No.	Chainage (m)		Direction	Radius (m)	Transition Length (m)		Curve Length (m)	Total Curve Length (m)	Straight Between (m)
	From	To			In	Out			
1	1,671	3,846	Right	6,000	300	300	1,575	2,175	11,706
2	15,552	20,460	Left	6,000	620	620	3,668	4,908	4,101
3	24,561	27,147	Left	2,000	370	370	1,846	2,586	2,697
4	29,844	31,529	Left	6,000	620	620	445	1,685	1,961
5	33,490	36,187	Right	6,000	620	620	1,456	2,696	624
6	36,810	42,376	Left	6,000	620	620	4,326	5,566	1,718
7	44,094	47,987	Right	6,000	620	620	2,653	3,893	103
8	48,090	52,141	Left	6,000	620	620	2,811	4,051	2,371
9	54,512	58,140	Right	4,000	530	530	2,568	3,628	3,814
10	61,955	64,341	Right	6,000	620	620	1,146	2,386	4,735
11	69,076	71,098	Left	6,000	620	620	782	2,022	7,996
12	79,095	81,457	Right	6,000	620	620	1,122	2,362	11,242
13	92,699	94,298	Right	8,000	620	620	360	1,600	26,641
14	120,939	125,334	Right	6,000	620	620	3,155	4,395	4,699
15	130,034	134,705	Left	6,000	620	620	3,431	4,671	3,277
16	137,983	140,157	Right	6,000	620	620	934	2,174	7,324
17	147,481	149,025	Right	8,000	620	620	304	1,544	20,777
18	169,802	172,909	Left	6,000	620	620	1,867	3,107	1,992
19	174,901	176,298	Right	6,000	620	620	157	1,397	25,935
20	202,233	203,594	Right	8,000	620	620	121	1,361	17,361
21	220,956	224,058	Left	6,000	620	620	1,863	3,103	11,054
22	235,112	236,919	Left	6,000	620	620	567	1,807	13,319
23	250,238	253,835	Right	6,000	620	620	2,357	3,597	16,376
24	270,211	271,676	Right	6,000	620	620	226	1,466	690
25	272,366	275,852	Left	6,000	620	620	2,246	3,486	11,024
26	286,876	291,698	Right	6,000	620	620	3,581	4,821	5,379
27	297,077	299,531	Left	6,000	620	620	1,214	2,454	12,784
28	312,315	314,093	Left	6,000	620	620	538	1,778	17,913
29	332,006	334,966	Right	6,000	620	620	1,720	2,960	26,009
30	360,974	363,100	Right	6,000	620	620	885	2,125	24,302
31	387,402	391,161	Left	6,000	620	620	2,519	3,759	3,038
32	394,199	394,467	Right	8,000	70	70	128	268	1,965
33	396,432	396,660	Left	1,500	30	30	168	228	797
34	397,458	398,028	Left	1,000	40	40	490	570	3,611
35	401,639	403,832	Right	1,500	320	320	1,553	2,193	348
36	404,180	406,721	Left	1,600	320	320	1,901	2,541	5,152
37	411,873	413,530	Left	6,000	620	620	417	1,657	4,512
38	418,041	420,496	Right	6,000	620	620	1,215	2,455	5,435
39	425,931	427,299	Left	8,000	620	620	128	1,368	13,273
40	440,572	443,896	Left	6,000	620	620	2,084	3,324	9,436
41	453,332	457,224	Right	6,000	620	620	2,652	3,892	29,936
42	487,160	489,939	Right	6,000	620	620	1,539	2,779	1,024
43	490,963	492,646	Left	6,000	620	620	443	1,683	151
44	492,797	493,417	Right	8,000	310	310	-	620	2,032
45	495,449	496,069	Right	8,000	310	310	-	620	1,900
46	497,969	498,137	Left	8,000	30	30	108	168	948
47	499,085	499,598	Right	1,000	120	120	273	513	321
48	500,217	500,374	Left	1,200	40	40	77	157	601
49	500,975	501,451	Left	1,000	50	50	375	475	1,590
50	503,040	503,681	Right	1,200	160	160	321	641	1,876
51	505,557	505,943	Left	1,200	80	80	226	386	568
52	506,511	506,836	Left	1,200	80	80	165	325	1,467

Source: Study Team

(10) More detailed studies

1) Comparison of four alternative route plans in Virar area

As shown in Figure 4.7-127 and Figure 4.7-128, four alternative route plans were considered in Virar area. In case-1, HSR route modified curve radius of previous HSR route from R 6,000 m to R 4,000 m for avoiding high-rise buildings under construction. Instead of reducing the number of crossing with DFC, the HSR route has to pass through a part of Quarry site. In case-2, HSR route pass across DFC at three times and pass near Vidya Vikasini Jr College. In case-3, HSR route pass across DFC at three times. In case-4, HSR route pass through the mountain designated as Tungareshwar Wildlife Sanctuary by tunnel and pass through many temporary houses.

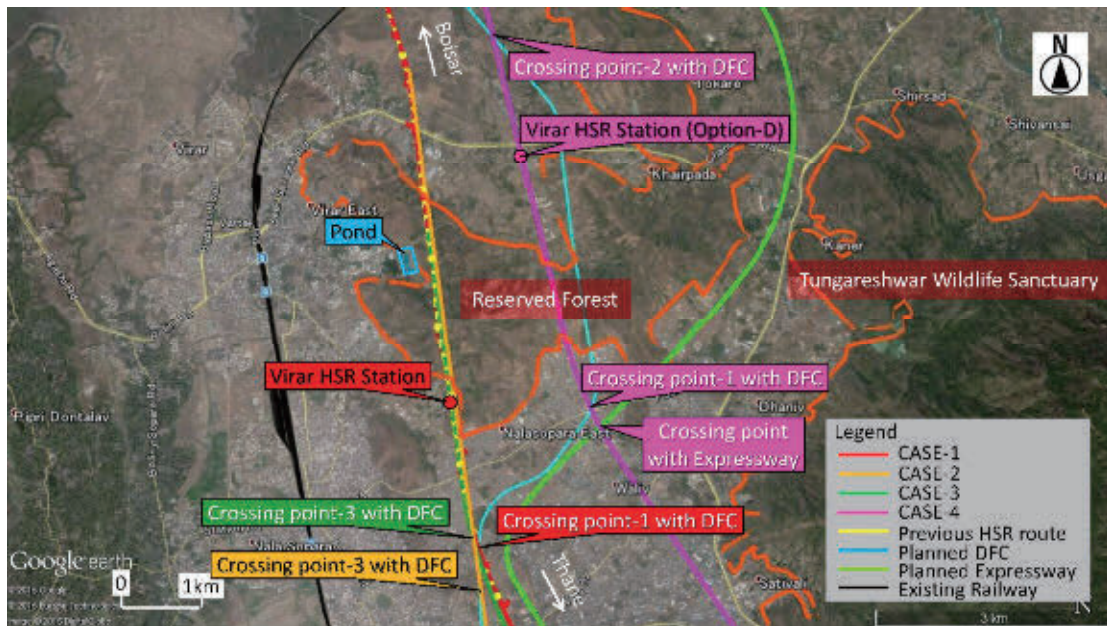

Source: Google Earth, study Team

Figure 4.7-127 Four Alternative Route Plans in Virar Area (1)

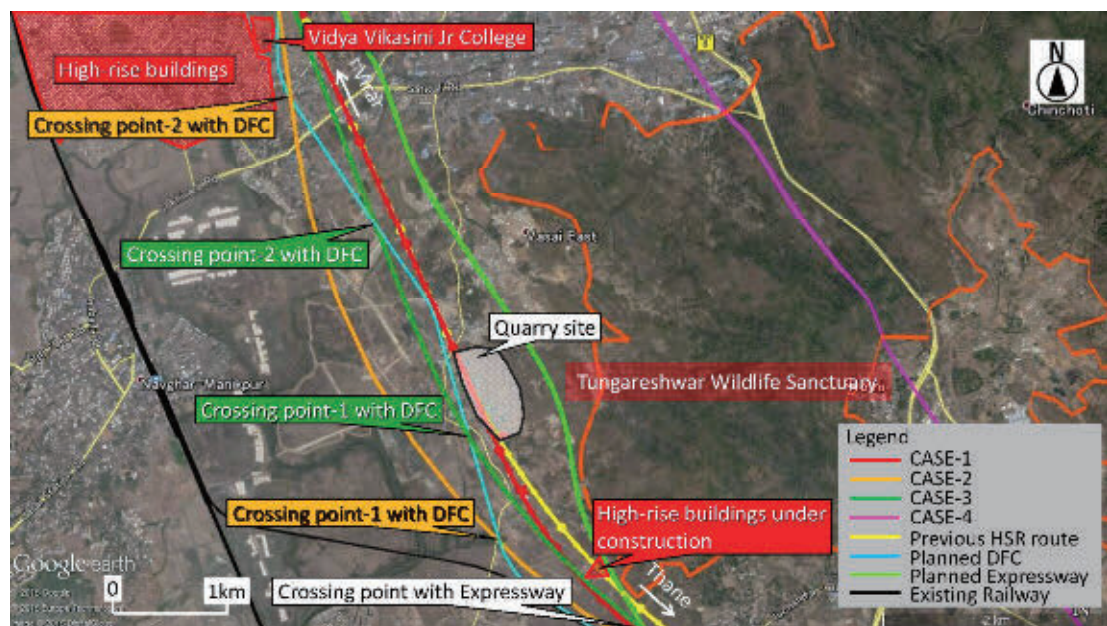

Source: Google Earth, study Team

Figure 4.7-128 Four Alternative Route Plans in Virar Area (2)

Table 4.7-26 shows comparison of four alternative route plans in Virar area. Based on several viewpoints such as the number of crossing with planned DFC and planned expressway, land acquisition, resettlement and environmental issues, these route plans were evaluated. In Table 4.7-26, red text indicates advantages and blue text indicates disadvantages.

Figure 4.7-129 shows comparison of draft profile-study concerning how to cross with DFC and Expressway on three alternative route plans and also Figure 4.7-130, Figure 4.7-131 and Figure 4.7-132 show draft structure-study concerning how to cross with them on three alternative plans.

Main points of evaluation are as follows:

- The number of crossing with DFC of case-1 is less than that of other cases.
- In all cases, the HSR route have to cross with expressway at one time.
- According to Figure 4.7-129, the rail level of case-1 can be lower than that of other cases.
- Any cases should be needed to carry out much land acquisition and resettlement of temporary houses.
- In the case-4, the HSR route have to pass through Tungareshwar wildlife sanctuary by tunnel. Even if passing by tunnel, it will take much time for getting a permit and an approval.

On overall evaluation, case-1 would be more desirable than other alternative route plans.

**Table 4.7-26 Comparison Table of Four Alternative Route Plans in Virar Area**

	CASE-1	CASE-2	CASE-3	CASE-4
The number of crossing with DFC	1 time	3 times	3 times	2 times
The number of crossing with Expressway	1 time	1 time	1 time	1 time
Land acquisition and resettlement	Much	So much	So much	Numerous
Natural Environmental issues	Avoid Wildlife Sanctuary	Avoid Wildlife Sanctuary	Avoid Wildlife Sanctuary	Pass through Wildlife Sanctuary by Tunnel
Total evaluation	✓✓✓	✓✓	✓	✓

Source: Study Team

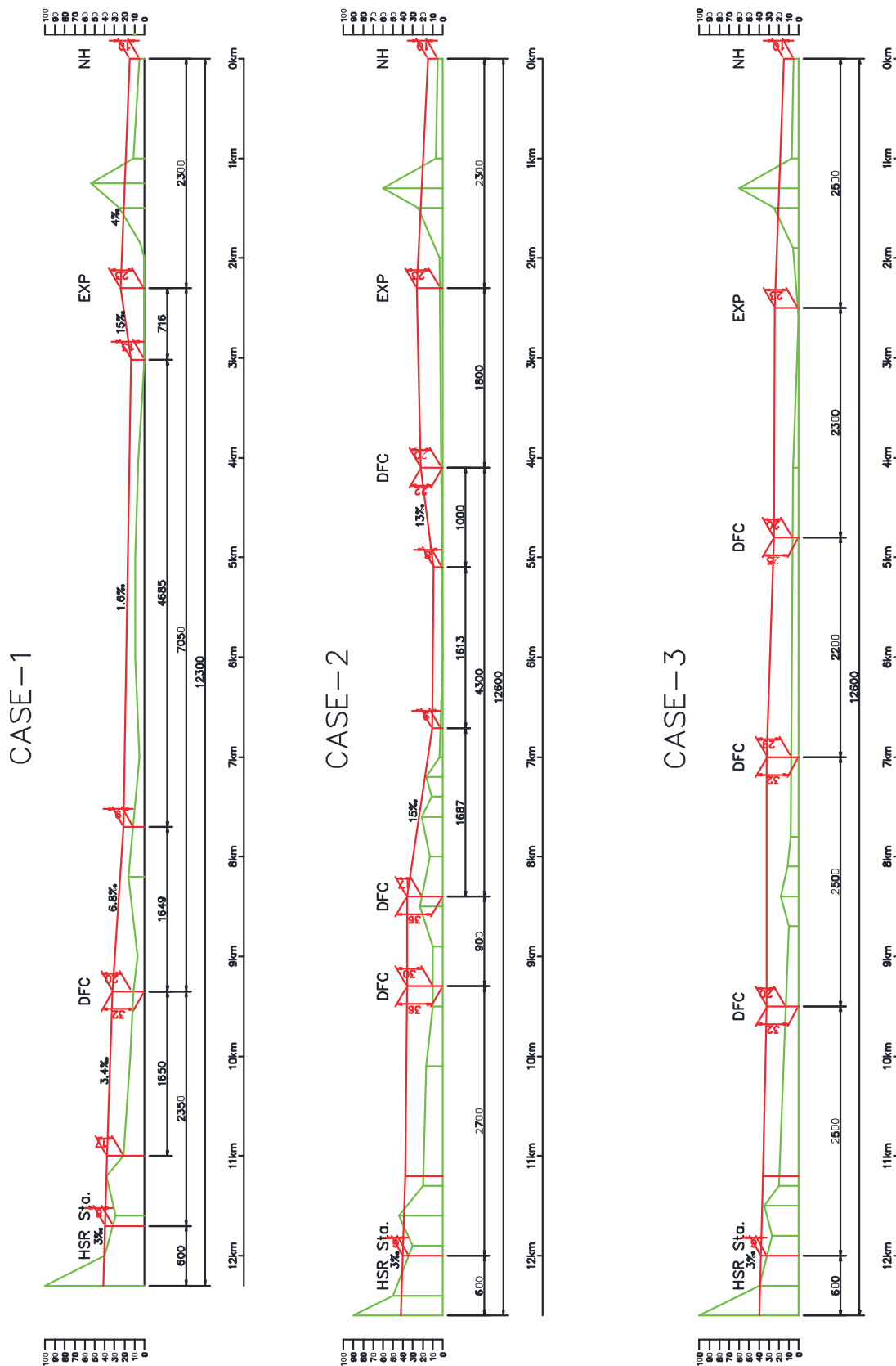

Source: Study Team

Figure 4.7-129 Comparison of Draft Profile-study Concerning How to Cross with DFC and Expressway



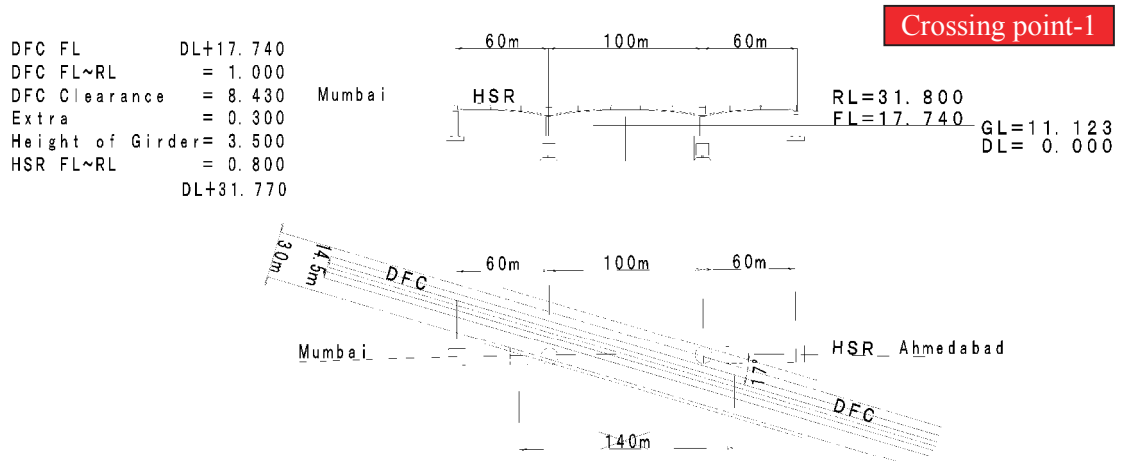

Source: Study Team

Figure 4.7-130 Draft Structure-study Concerning How to Cross with DFC on Case-1

Crossing point-1

DFC FL	DL+ 8.204			
DFC FL~RL	= 1.000			
DFC Clearance	= 8.430			
Extra	= 0.300	Mumbai HSR	RL=22.300	
Height of Girder	= 3.500	GL= 2.147	FL= 8.204	DL= 0.000
HSR FL~RL	= 0.800			
	DL+22.234			

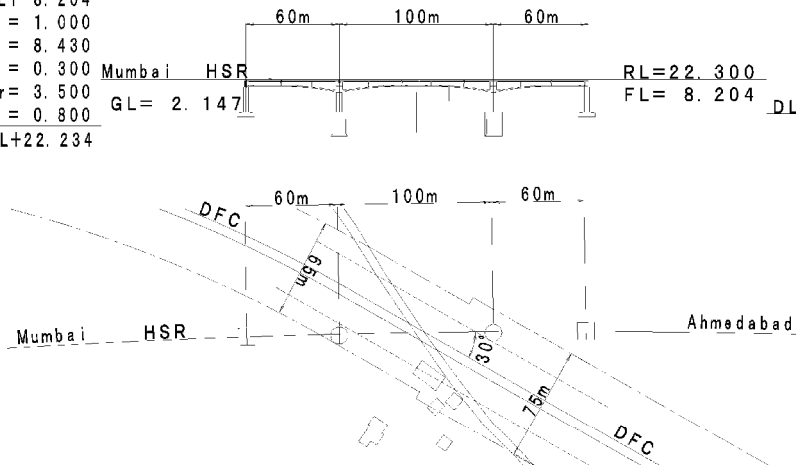

Crossing point-2

DFC FL	DL+22.245			
DFC FL~RL	= 1.000			
DFC Clearance	= 8.430			
Extra	= 0.300			
Height of Girder	= 3.500			
HSR FL~RL	= 0.800	Mumbai HSR	RL=36.300	
	DL+36.275	GL=18.859	FL=22.245	DL= 0.000

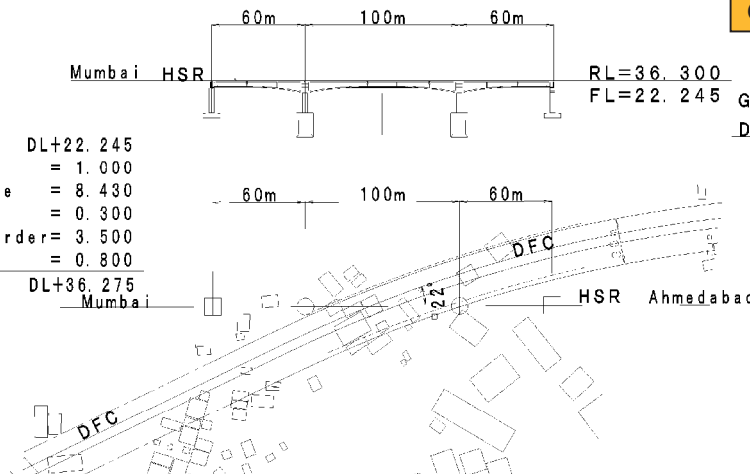

Crossing point-3

DFC FL	DL+19.640			
DFC FL~RL	= 1.000			
DFC Clearance	= 8.430			
Extra	= 0.300			
Height of Beam	= 2.500			
Height of Bearing	= 0.500			
Height of Girder	= 3.000			
HSR FL~RL	= 1.000	Mumbai HSR	RL=36.400	
	DL+36.370	GL=6.510	FL=19.640	DL= 0.000

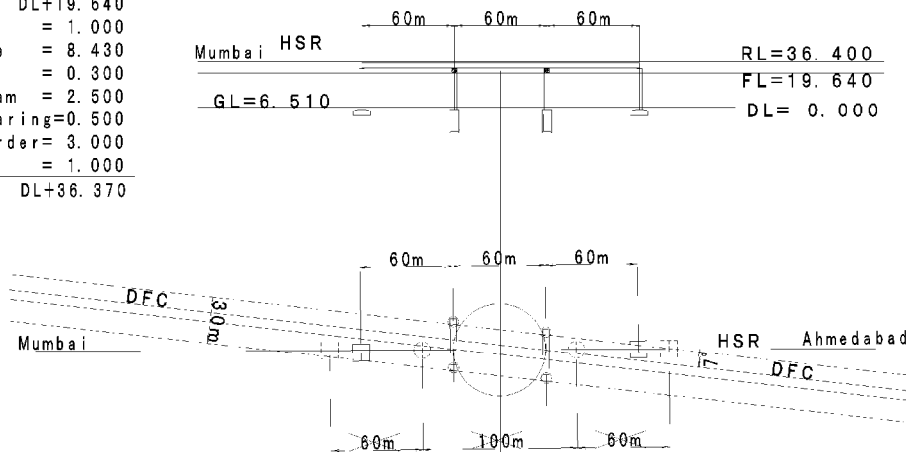

Source: Study Team

Figure 4.7-131 Draft Structure-study Concerning How to Cross with DFC on Case-2

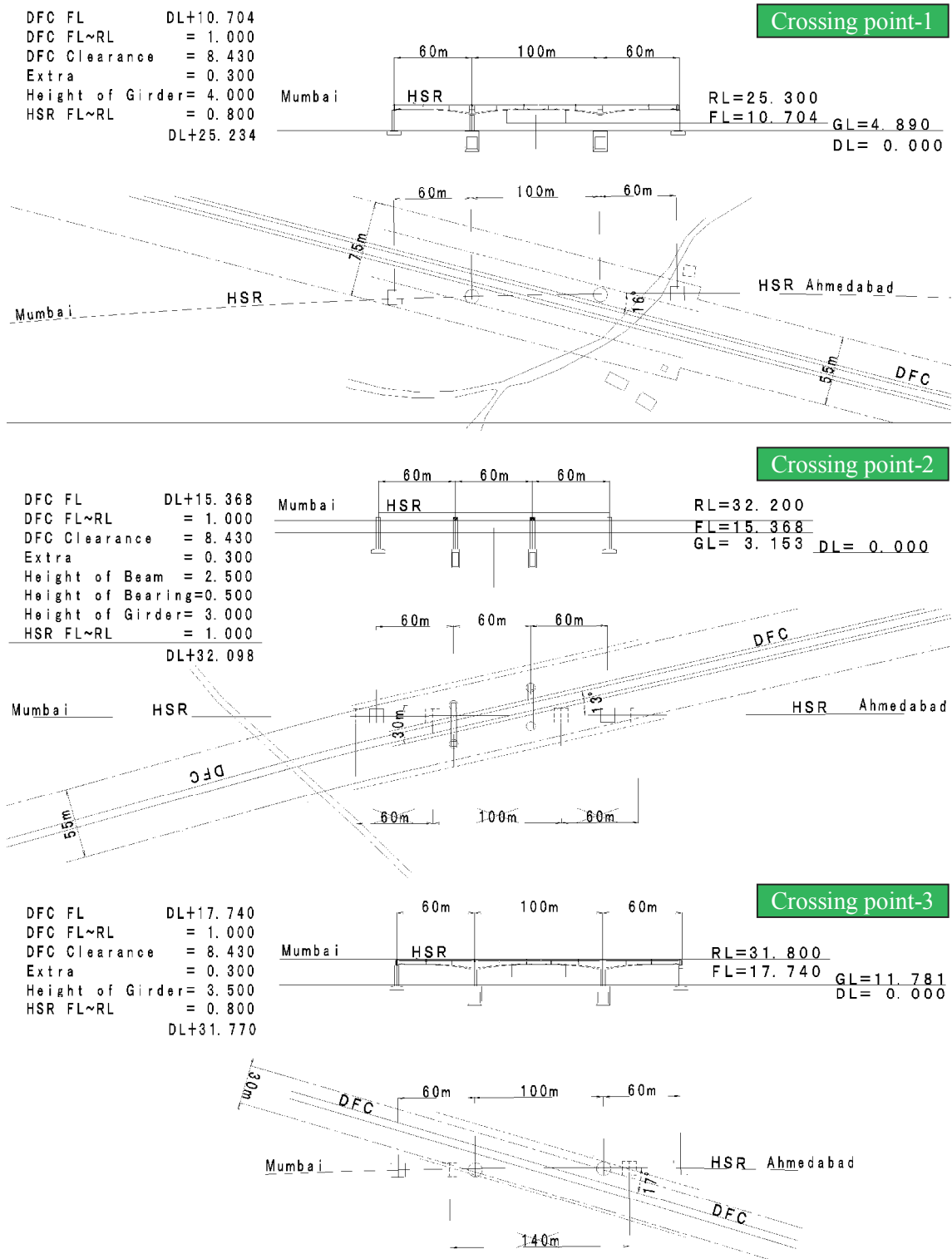

Source: Study Team

Figure 4.7-132 Draft Structure-study Concerning How to Cross with DFC on Case-3

## 2) Comparison of two alternative route plans in Vadodara area

As shown in Figure 4.7-133, two alternative route plans were considered in Vadodara area. In case-1, HSR route pass along the existing railway line and HSR station juxtaposed to Vadodara existing railway station on west side. In case-2, HSR station located at west suburban of Vadodara city approx. 10 km away from city center.

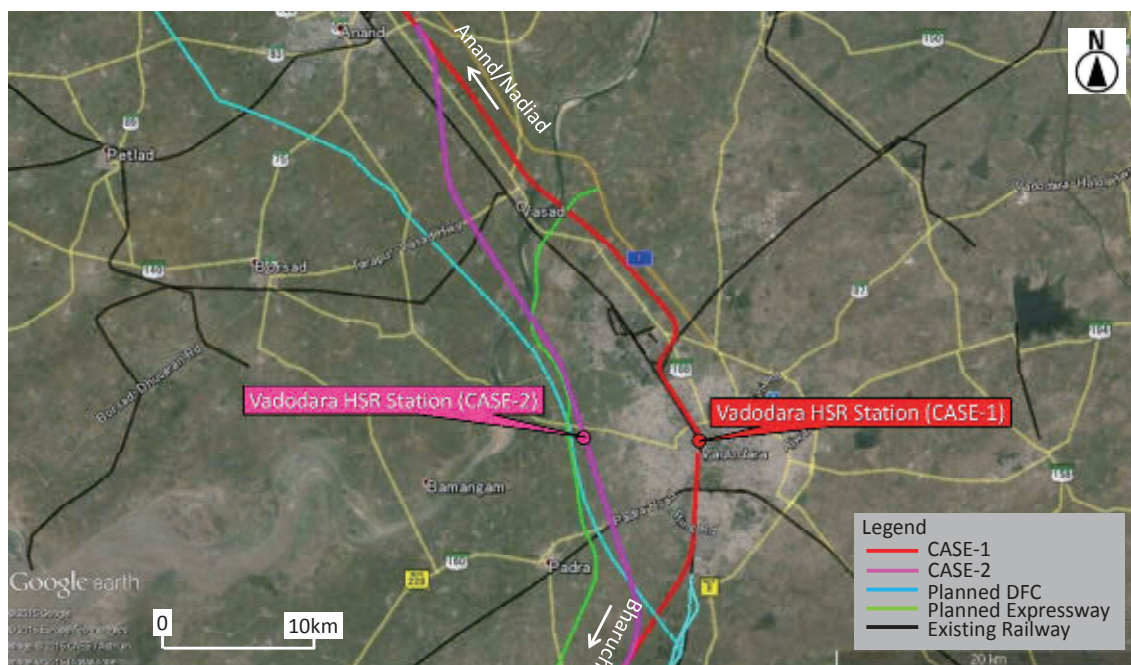

Source: Google Earth, study Team

Figure 4.7-133 Two Alternative Route Plans in Vadodara Area

Table 4.7-27 shows comparison of two alternative route plans in Vadodara area. Based on several viewpoints such as connectivity with existing railway station, land acquisition, difficulty of construction and traffic potential, these route plans were evaluated. In Table 4.7-27, red text indicates advantage and blue text indicates disadvantage.

Main points of evaluation are as follows:

- Case-1 can only connect to Vadodara existing railway station and can also be expected to transfer from existing railway station compared with case-2. Furthermore, there is no plan of construction of metro line in Vadodara city at the moment. In case-2, passengers for business have to move between suburban area and city center by transportation such as car or bus.
- In the viewpoint of difficulty of construction, case-2 will be more desirable than case-1 due to green field area.
- Case-1 has much greater traffic potential as commercial and residential areas near the HSR station.

On overall evaluation, case-1 appears to be a much better than case-2 as it serve the CBD and will attract more passengers. Moreover, in case 2, the land acquisition costs will be very significant.



Table 4.7-27 Comparison Table of Two Alternative Route Plans in Vadodara Area

	CASE-1	CASE-2
Station location	Juxtaposed to Vadodara Existing Rly Sta. (elevated)	West side 9 km away from Vadodara city center. (elevated)
Connectivity with Existing Railway	Good connectivity with existing railway	None. Access by car or bus will be needed
Land acquisition	Partial land of Indian railway Private land acquisition will be needed	Green field area
Difficulty of Construction	A Little hard to construct	Easy to construct
Traffic Potential	Huge. Expected to transfer from Existing Rly Sta.	Small. Development plan will be needed
Total evaluation	✓✓	✓

Source: Study Team

### 3) Comparison of two alternative route plans in Ahmedabad area

As shown in Figure 4.7-134, two alternative route plans were considered in Ahmedabad area. In case-1, HSR route pass along the existing railway line and HSR stations juxtaposed to Ahmedabad existing railway station on east side and between East and West Sabarmati existing railway stations. In case-2, HSR stations connected to the end station of planned east-west metro line and east side of planned Gift city.



Source: Google Earth, study Team

Figure 4.7-134 Two Alternative Route Plans in Ahmedabad Area

Table 4.7-28 shows comparison of two alternative route plans in Ahmedabad area. Based on several viewpoints such as connectivity with mass transport system, land acquisition, difficulty of construction, traffic potential and possibility of future extension to Delhi, these route plans were evaluated. In Table 4.7-28, red text indicates advantages and blue text indicates disadvantages.

Main points of evaluation are as follows:

- Case-1 will connect to an existing railway station and a planned metro station at each HSR station. On the other hand, case-2 will connect to a planned metro station and planned Gift city. Both alternative routes can be expected huge traffic potential.
- In the viewpoint of land acquisition, in case-1, resettlement will not be too much due to alignment passing within land of Indian railway. In case-2, resettlement will be needed along Sardar Patel Ring Road. Moreover, land acquisition will be involved.
- In viewpoint of difficulty of construction, case-1 will be a little more difficult to construct due to passing through existing railway line and station. On the other hand, case-2 will be basically easy to construct except section passing along Sadar Patel Ring Road.
- Case-1 has a distinct advantage as the HSR station will be accessible to existing rail passengers and is located close to CBD and residential areas.
- Both case-1 and case-2 have a possibility of future extension to Delhi.

On overall evaluation, case-1 is recommended.

Table 4.7-28 Comparison Table of Two Alternative Route Plans in Ahmedabad Area

	CASE-1	CASE-2
Station location	Juxtaposed to Ahmedabad & Sabarmati Existing Rly Sta. (elevated)	Connected to Planned Metro Sta. and Planned Gift city (elevated)
Connectivity with Mass Transport system	Good connectivity with an Existing Rly Sta. and a Planned Metro Sta. at each HSR station	Good connectivity with a Planned Metro Sta. and Planned Gift city
Land acquisition	Land of Indian railway, depot and workshop is within land of Indian railway	Resettlement will be needed along Sardar Patel Ring Road. Huge land acquisition will be needed for depot and workshop.
Difficulty of Construction	A Little hard to construct	Basically easy to construct, a little hard to construct along Sardar Patel Ring Road
Traffic Potential	Huge. Expected to transfer from a Existing Rly Sta. & a Planned Metro Sta. at each HSR station	Huge. Expected to transfer from a Planned Metro Sta. & Planned Gift city
Possibility of future extension to Delhi	Possibility future extension to Delhi	Possibility future extension to Delhi
Total evaluation	✓✓✓	✓✓

Source: Study Team

#### 4) Study in the case HSR route Parallels Expressway

##### a) Basic issues

Basic issues in the case HSR route parallels expressway are as follows:

- The geometric standards for HSR are stricter than that for Expressway, so the expressway route may not be appropriate for HSR.
- The expressway passes at the outskirts of the city areas, so if HSR also follows the same route, then HSR stations will have to be located in the outskirts of the city.
- The interchanges of expressway are located at about 20 - 70 km interval. This will pose problems for land acquisition near the interchange locations.
- If we have to avoid additional land acquisition, then HSR needs to be elevated at these locations which will lead to more costs.
- HSR route interferes the service road of Expressway.
- It is expected that it would take much time for negotiating with National Highways Authority of India.

##### b) Proposed section of planned Expressway route in the case HSR route parallels Expressway

Basic issues have been described as above, as shown in Figure 4.7-135, if HSR route is selected as paralleling expressway between Mumbai and Vadodara, HSR route would parallel Expressway between Bharuch and Vadodara.

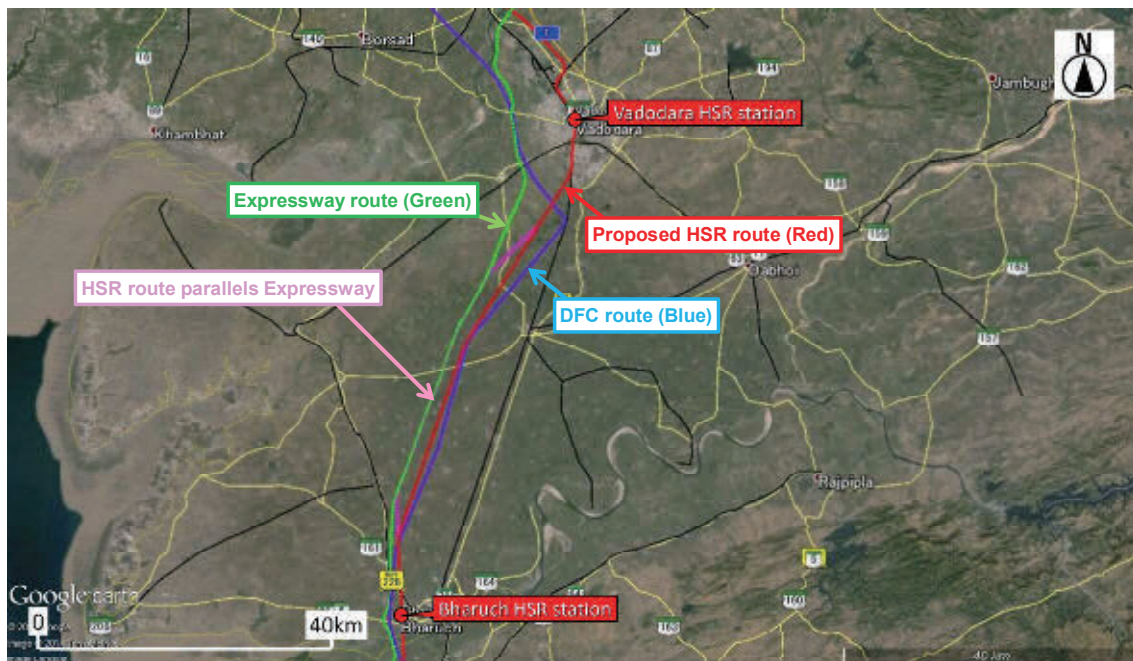

Source: Google Earth, study Team

Figure 4.7-135 Proposed Section of Planned Expressway Route in the Case HSR Route Parallels expressway

c) Case studies

According to executive summary of Development of Vadodara Mumbai Expressway, Dec 2013, as shown in Figure 4.7-136, the width of road is 54 m and the width of right of way is 100 m or 120 m. assuming that embankment height is 5 m, horizontal distance between top and end of slope will be 15 m. Therefore, the rest of land width will be 8 m or 18 m.

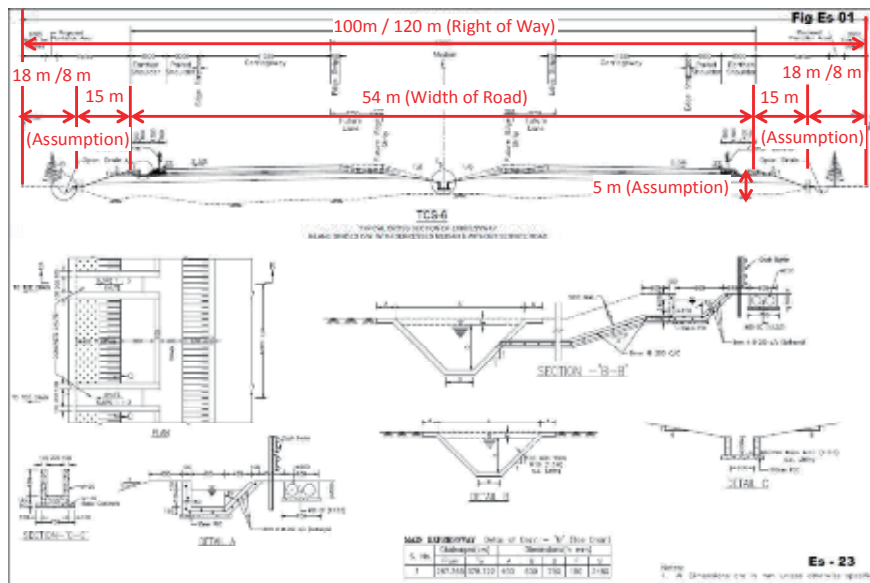

Source: Executive summary, Development of Vadodara Mumbai Expressway, Dec 2013

Figure 4.7-136 Typical Cross Section of Planned Expressway

As shown in Figure 4.7-137, if the width of right of way of expressway is 120 m, the viaduct of HSR will be within the rest of right of way. However, if the width of right of way is 100 m, a part of viaduct of HSR will be not within the rest of right of way.

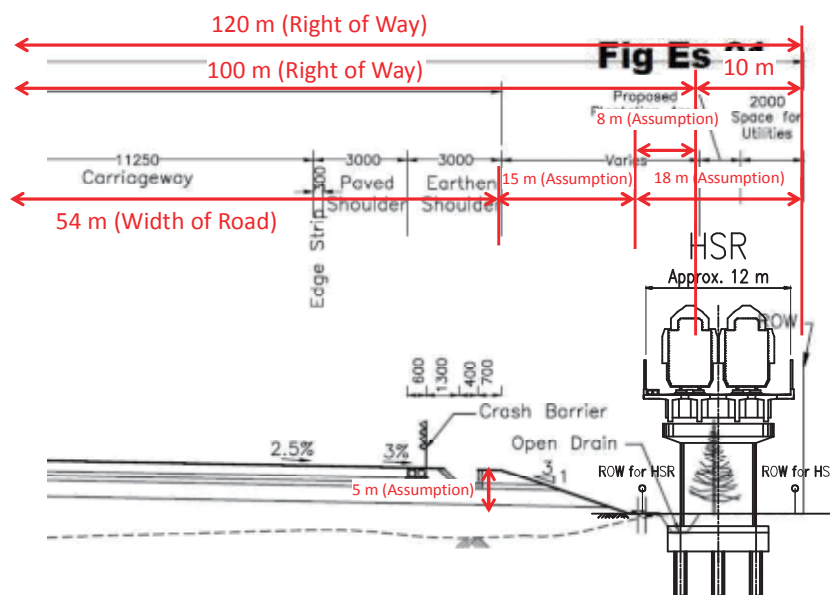

Source: Executive summary, Development of Vadodara Mumbai Expressway, Dec 2013

Figure 4.7-137 Typical Cross Section of Planned Expressway in the Case of HSR-Viaduct (1)



As shown in Figure 4.7-138, there will be the following condition on some locations due to difference of criteria between HSR and Expressway. A part of viaduct of HSR will be within the slope of embankment.

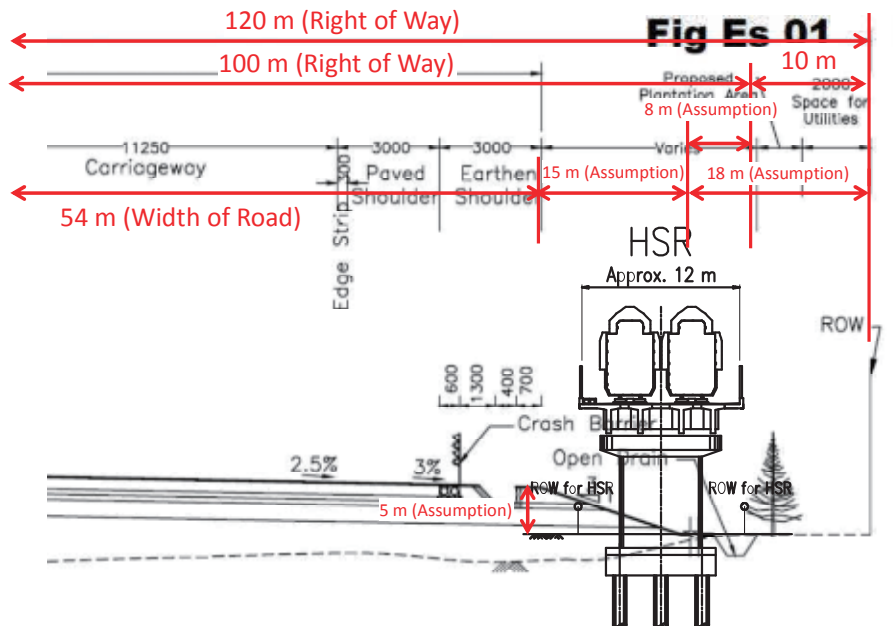

Source: Executive summary, Development of Vadodara Mumbai Expressway, Dec 2013

Figure 4.7-138 Typical Cross Section of Planned Expressway in the Case of HSR-Viaduct (2)

As shown in Figure 4.7-139, there is a service road on some sides of expressway. HSR route will interfere the service road of Expressway.

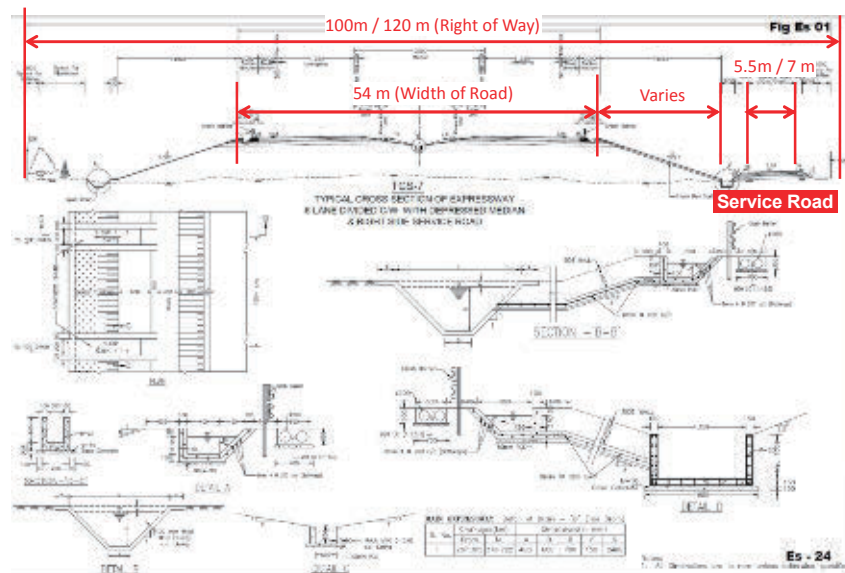

Source: Executive summary, Development of Vadodara Mumbai Expressway, Dec 2013

Figure 4.7-139 Typical Cross Section with Service Road of Planned Expressway

## Chapter 5 Review of Travel Demand Forecasts and Setting of Fare Levels

### 5.1 Traffic Surveys

#### 5.1.1 Introduction

Following traffic surveys were carried out by the Study Team to understand the present travel patterns and to build models for forecasting future passenger demand for High-Speed Rail.

(1) Willingness-To-Pay (WTP) Survey

(2) Classified Traffic Count Survey

(3) Car O-D Interview Survey

#### 5.1.2 Willingness-To-Pay (WTP) Survey

##### (1) Willingness-To-Pay (WTP)

The purpose of this survey is to a) understand the preference of long distance passengers (air passengers, train passengers, car passengers and bus passengers) to different levels of fare of HSR. b) to develop a modal split model for forecasting future travel demand in the Study area.

This survey was conducted by interviewing long-distance passengers in the four major cities i.e. Mumbai, Ahmedabad, Surat and Vadodara. All type of long distance passengers (air passengers, train passengers, car passengers and bus passengers) were interviewed. Passenger interviews were done at airports, railway stations, bus terminals and car rest areas. This survey was conducted both on weekdays and weekends. Table below shows the number of passengers interviewed (sample size) by city and mode.

Table 5.1-1 Number of Passengers Interviewed for WTP Survey

City/Mode	Air Passengers	Train Passengers	Car Passengers	Bus Passengers	Total
Ahmedabad	635	425	424	584	2068
Mumbai	871	469	415	391	2146
Surat	101	354	397	308	1160
Vadodara	235	415	552	393	1595
<b>Total</b>	<b>1842</b>	<b>1663</b>	<b>1788</b>	<b>1676</b>	<b>6969</b>

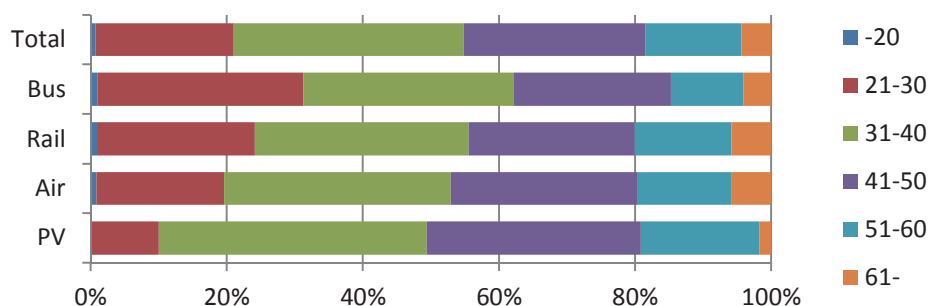

Figure 5.1-1 Number of Passengers Interviewed by Age Group

WTP survey for train passengers was done for passengers riding AC class (1A, 2A, CC and EC) trains at Mumbai Station, Ahmedabad, Surat and Vadodara Stations. For air passengers, passengers at Mumbai, Ahmedabad, Surat and Vadodara airport were interviewed. For bus passengers, passengers riding AC class at Mumbai, Ahmedabad, Surat and Vadodara bus terminals were interviewed. For car passengers, car passengers/drivers at rest areas along the Mumbai – Ahmedabad corridor were interviewed.

#### Fare Levels and Travel time for HSR

Four different fare levels for HSR were considered for WTP survey as shown in Table below. For the survey, total fare was considered to be on-board fare plus access/ egress fare. Similarly total travel time was taken as on-board travel time plus access/egress time. The on-board travel time of 2 hrs was considered for HSR between Ahmedabad and Mumbai.

Table 5.1-2 Four Levels of HSR Fare for WTP Survey

Fare 1	HSR fare = 1st AC Train fare
Fare 2	HSR fare = 1st AC train fare + 33% of difference between 1st AC train fare and Air fare.
Fare 3	HSR fare = 1st AC train fare + 66% of difference between 1st AC train fare and Air fare.
Fare 4	HSR fare = Air fare (economy class)

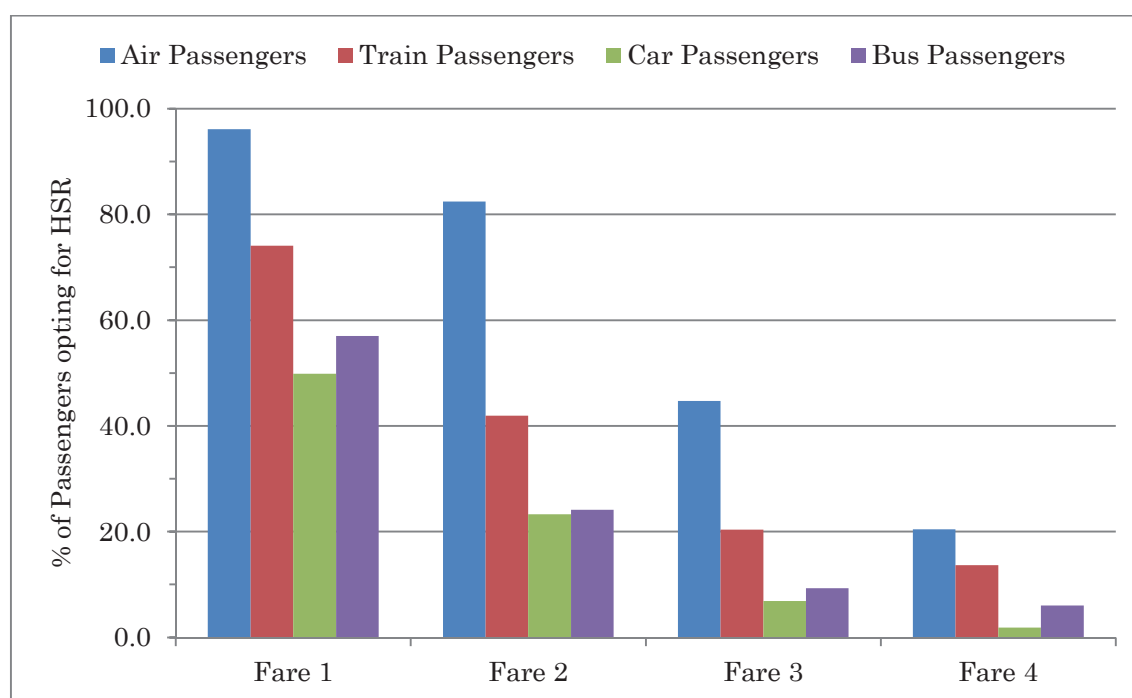

Figure 5.1-2 % of Passengers Opting for HSR at Different Fare Levels

The Figure above shows the preference of passengers for different levels of fare for HSR. One important observation is that about 40% of existing AC class train passengers will prefer HSR even at fare level 2.

(2) Modal Choice

Following figure shows the reason why passenger chose a particular transportation mode.

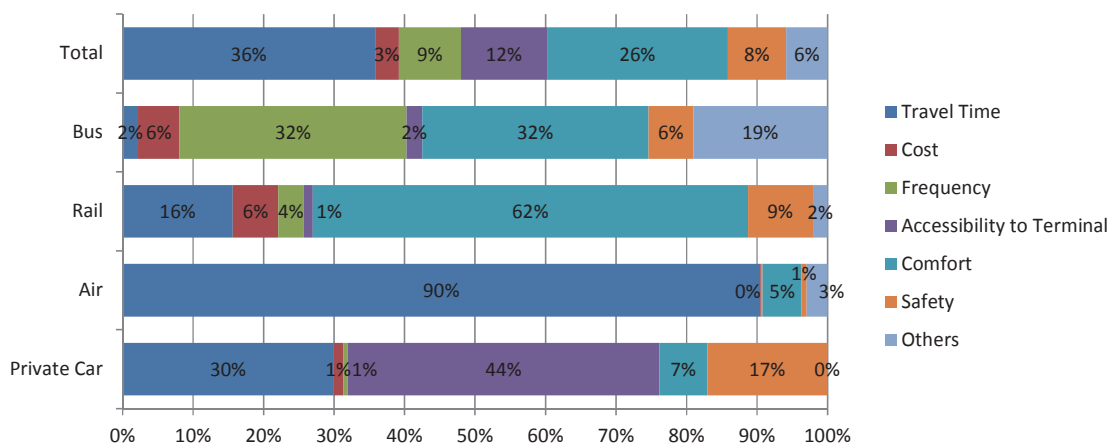

Figure 5.1-3 Reason for Mode Choice

As can be seen from the figure above, 90% of air passengers said that they chose air travel because of short travel time. 62% rail passengers chose rail travel because it is comfortable.



### 5.1.3 Classified Volume Count (CVC) Survey

The purpose of this survey is to obtain traffic volume counts of road vehicles on the main highways along the Mumbai-Ahmedabad corridor. The survey was conducted in April 2014 at the locations shown in Figure below. This CVC survey was conducted for 2 days (1 weekday and 1 weekend), and traffic count data was recorded for both the direction. The total traffic count for the survey locations was 161,894 car/van, 7,405 buses and 156,797 trucks/goods vehicles.

### 5.1.4 Car O-D Survey

The purpose of this survey is to collect data regarding the movement of car passengers in the study area. The results of this survey will be used to prepare present car OD matrix for car passengers.

The car OD survey was conducted in April 2014 by roadside interview method and, at the same locations as that of traffic count survey. The survey was conducted for 2 days (1 weekday and 1 weekend) and a total of 65,417 persons were interviewed and a sampling rate of 20.47% was achieved. This survey was meant only for car passengers, so trucks and other freight vehicles were not surveyed.

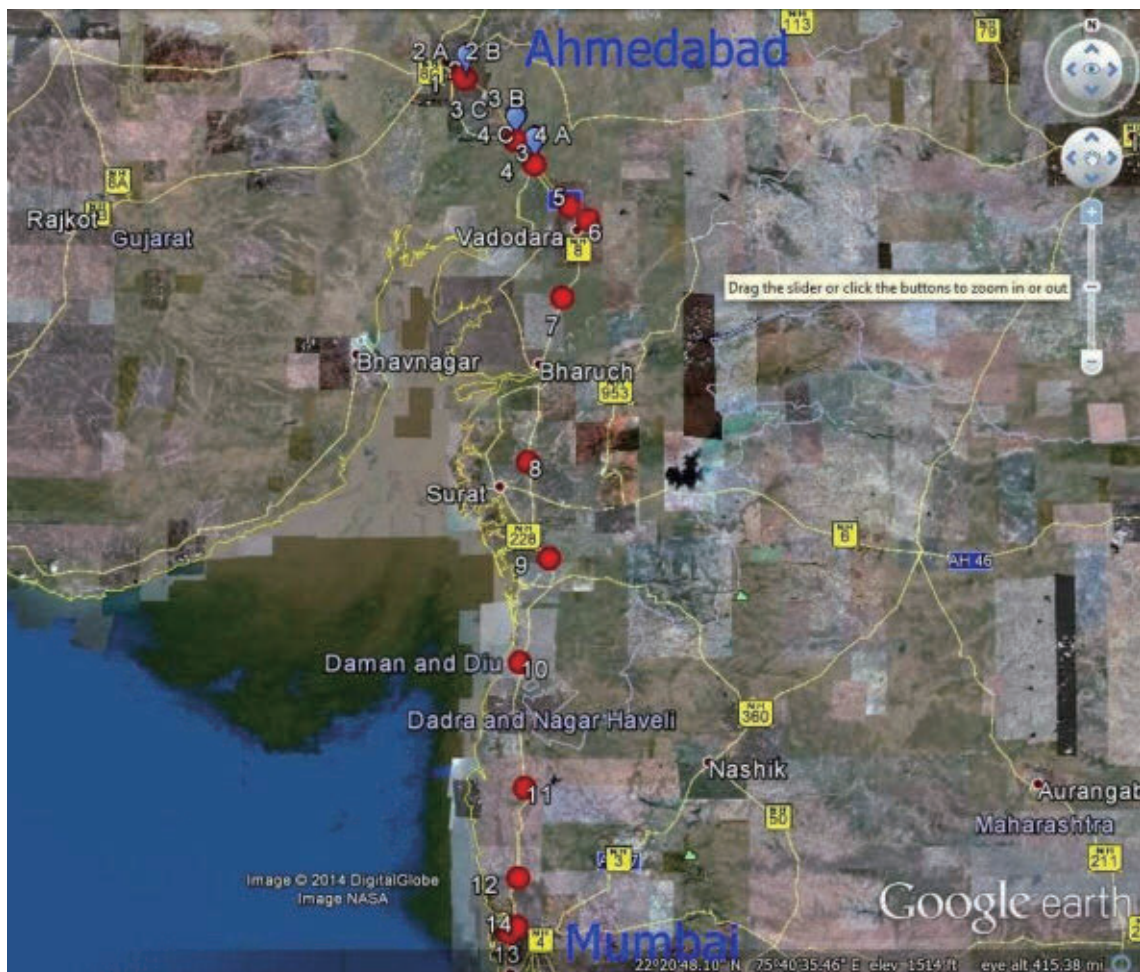

Figure 5.1-4 Location of Survey Points for Traffic Count and OD Survey

**Table 5.1-3 Locations for Traffic Count and Car OD Survey**

Location No.	Location Name	Location District
1	At Ahmedabad Toll Plaza on Mahatma Gandhi Expressway	Ahmedabad District
2A	At Toll plaza for Mumbai-Rajasthan section, at Interchange of Mahatma Gandhi Expressway and Sardar Patel Ring Road	Ahmedabad District
2B	At Toll plaza for Mumbai - Rajkot section, at Interchange of Mahatma Gandhi Expressway and Sardar Patel Ring Road	Ahmedabad District
3A	At Nadiad Toll Plaza, for Vadodara - Dakor section, at Interchange of Mahatma Gandhi Expressway and Gujarat State Highway 12	Kheda District
3B	At Nadiad Toll Plaza, for Nadiad - Vadodara section, at Interchange of Mahatma Gandhi Expressway and Gujarat State Highway 12	Kheda District
3C	At Nadiad Toll Plaza, for Nadiad - Ahmedabad section, at Interchange of Mahatma Gandhi Expressway and Gujarat State Highway 12	Kheda District
3D	At Nadiad Toll Plaza, for Ahmedabad - Dakor section, at Interchange of Mahatma Gandhi Expressway and Gujarat State Highway 12	Kheda District
4A	At Anand Toll Plaza, for Anand - Vadodara, at Interchange of Mahatma Gandhi Expressway and Gujarat State Highway 60	Anand District
4B	At Anand Toll Plaza, for Anand - Ahmedabad, at Interchange of Mahatma Gandhi Expressway and Gujarat State Highway 60	Anand District
4C	At Anand Toll Plaza, for Ahmedabad - Bhalej, at Interchange of Mahatma Gandhi Expressway and Gujarat State Highway 60	Anand District
4D	At Anand Toll Plaza, for Bhalej - Vadodara, at Interchange of Mahatma Gandhi Expressway and Gujarat State Highway 60	Anand District
5	Vadodara Toll Plaza (Mahatma Gandhi Express way)	Vadodara District
6	Godhra Toll Plaza (State Highway- 87)	Vadodara District
7	L & T Karjan Toll Plaza (National Highway- 8)	Vadodara District
8	Choryasi Toll Plaza ( National Highway- 8)	Surat District
9	Navsari Toll Plaza ( National Highway- 8)	Navsari District
10	Bagwada Toll Plaza ( National Highway- 8)	Valsad District
11	Charoti Toll Plaza ( National Highway- 8)	Thane District
12	Khaniwada Toll Plaza ( National Highway- 8)	Thane District
13	Godhbander Toll Plaza ( State Highway-42)	Thane District
14	Dahisar Toll Plaza ( National Highway- 8)	Mumbai Suburban

Table 5.1-4 Traffic Volume Count at by Vehicle Type  
(in Vehicles per Day, for Both Directions, on Weekday)

Location No.	Car/Jeep/ Van	Bus	Trucks/ Goods	Total
1	10,788	1,579	1,817	14,184
2A	1,993	113	2,309	4,415
2B	5,508	201	6,068	11,777
3A	124	5	107	236
3B	996	96	567	1,659
3C	1,139	53	236	1,428
3D	366	145	188	699
4A	1,195	95	1,754	3,044
4B	1,788	257	1,372	3,417
4C	149	15	154	318
4D	494	66	806	1,366
5	18,737	1,802	9,144	29,683
6	2,296	443	6,685	9,424
7	9,347	1,465	17,507	28,319
8	9,305	1,765	19,001	30,071
9	8,499	808	20,740	30,047
10	13,303	903	18,214	32,420
11	7,326	563	14,240	22,129
12	10,573	597	13,520	24,690
13	13,846	2,477	9,840	26,163
14	44,122	3,957	12,528	60,607
Total	161,894	17,405	156,797	336,096

## 5.2 Optimum Fare Study for HSR

### 5.2.1 Cross Country Study

#### (1) Income Level Study

Willingness to pay, the amount that an individual is willing to sacrifice to procure the transportation service, highly depends on the income level of passengers. Following figure shows the GDP per capita as of 2012 in USD at current price. The GDP (nominal) per capita in India is approximately USD 1,500 in 2012. Comparing the countries which have the HSR, the GDP per capita in India as of 2012 is low. For instance, the GDP per capita in France is 28 times of the GDP per capita in India. Even if it is assumed that the GDP will increase at 5 to 7 percent as shown in chapter 2 in Interim Report 1, the GDP per capita in India in 2023, the year of opening HSR, is USD 4,580. Considering the fact, it is assumed that the travelers in India regard the cost as important more than travel time comparing with the developed countries.

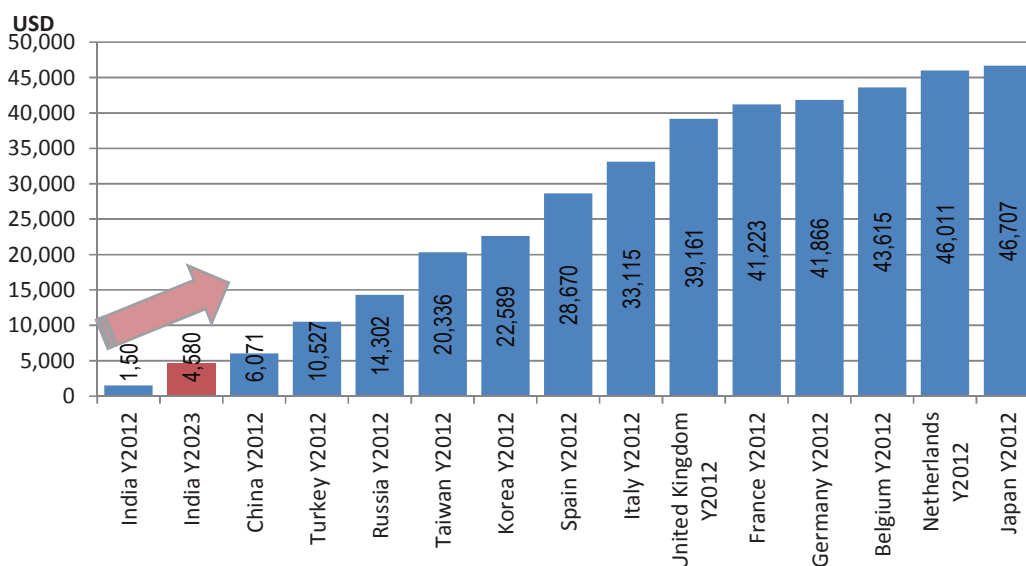

Source: IMF and JICA Study Team

Figure 5.2-1 GDP per Capita (Nominal)

#### (2) Fare for High Speed Railway

Following figure shows the unit fare for High Speed Railway in USD by distance by country. As shown in the figure, the unit fare is high in the country with high GDP per capita.

If the India try to aim for the service level of China or Russia for the time being, it is recommended that the unit fare level for HSR should be range of 0.08 – 0.14 USD (Rs. 4.72 – 8.85) per kilometer, same as China or Russia as of 2012.<sup>2</sup>

<sup>1</sup> This estimate considers the GDP deflator from 2012 to 2023 at 1.83.

<sup>2</sup> In Turkey, HSR is operated short section, 245 – 290km, only. Unit fare is different by distance as well as country.



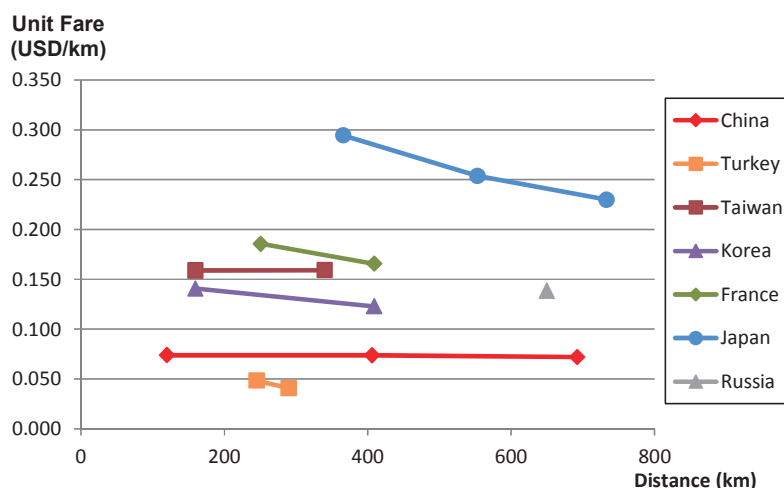

Source: JICA Study Team

Figure 5.2-2 Unit Fare of High Speed Railway (USD)<sup>3</sup>

## 5.2.2 Fare Level for Other Transportation Modes

### (1) Air Fare

Table 5.2-1 shows the service level of air transport. Between Mumbai and Ahmedabad, the average travel time and fare is approximately 75 minutes and Rs. 4,100, respectively.

Table 5.2-1 Service Level of Air Transport

Airport		Travel Time(Hr:m)	Fare (RS.)	Frequency / day	Capacity /day
Ahmedabad	Delhi	1:26	6,416	22	3,306
Ahmedabad	Mumbai	1:14	4,143	28	4,134
Ahmedabad	Pune	1:15	5,407	6	662
Vaodara	Delhi	1:31	4,166	4	600
Vaodara	Mumbai	1:08	4,777	10	1,524
Surat	Delhi	1:46	7,028	2	416
Surat	Mumbai	0:52	2,370	2	324
Mumbai	Delhi	2:06	7,916	88	13,593
Mumbai	Pune	0:55	6,226	2	324
Pune	Delhi	2:07	8,148	26	4,009

Source: JICA Study Team<sup>4</sup>, DCA

### (2) Rail Fare

Table 5.2-2 and Figure 5.2-3 shows the fare structure of railway fare by seat class.

<sup>3</sup> Exchange rate: Broomburg as of April 2014.

<sup>4</sup> Air Fare is studied on web-site of air carriers in May 2014.

Table 5.2-2 Railway Fare by Seat Class by Distance

Seat Class/Distance	50km	100km	200km	300km	400km	500km	750km
1A	1,120	1,120	1,120	1,120	1,328	1,537	2,058
2A	672	672	672	672	793	913	1,214
3A	487	487	487	487	569	650	854
Exe. CI	496	589	776	963	1,150	1,337	1,805
FC	241	241	345	449	553	657	917
CC	277	277	312	381	450	519	692
SL	101	118	152	187	221	255	341
II	42	52	72	92	112	132	182

Source: Trains at a Glance

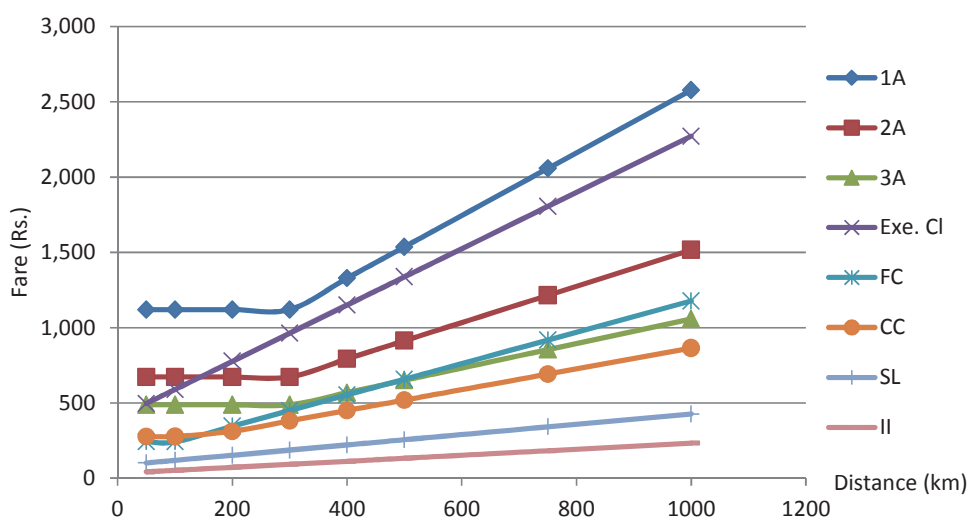

Source: JICA Study Team,

Figure 5.2-3 Railway Fare by Seat Class

### (3) Bus Fare

Table 5.2-3 shows the service level of A/C bus service. Between Mumbai and Ahmedabad, the average fare for A/C class is approximately Rs. 1200.

Table 5.2-3 A/C Bus Fare by Route

Origin		Destination		Distance (km)	Fare (Rs.)
Gandhinagar		Surat	Bombay Market Parking	292	450
Ahmedabad	Nehru Nagar	Vadodara	GSRTC Naya Bus Stand	116	240
		Surat	Lal Darwaja	258	520
		Vishala		Nadiad	59
	Vishala		Anand	72	730
	Vadodara	Shashtri Bridge	113	500	
	Surat	Bombay Market Parking	258	730	
	Vishala		Navsari	284	400
	Vishala		Valsad	330	700
	Vishala		Vapi	359	800
	Vishala		Mumbai	Mumbai Central	526

		Thane		502	830	
		Panvel		528	1200	
		Pune		646	1200	
		Nashik		457	800	
Nadiad		Vadodara	Shashtri Bridge	59	700	
		Surat	Parvat Patiya & Vrl Logistics	202	700	
		Mumbai	Mumbai Central	472	1100	
Anand		Vadodara	Shashtri Bridge	45	700	
		Surat	Parvat Patiya & Vrl Logistics	188	700	
		Mumbai	Mumbai Central	458	1000	
Vadodara	Makarpura	Surat	Lal Darwaja	132	335	
	Shashtri Bridge	Bharuch		80	400	
		Surat	Bombay Market Parking	146	700	
		Navsari		172	700	
		Valsad		218	800	
		Vapi		247	800	
		Mumbai	Mumbai Central	414	1000	
		Thane		391	800	
		Panvel		417	800	
		Pune		531	1000	
		Nashik		343	800	
		Bharuch	Surat	Parvat Patiya & Vrl Logistics	69	350
			Mumbai	Mumbai Central	339	800
Surat	Parvat Patiya & Vrl Logistics	Navsari		41	500	
		Valsad		88	400	
		Vapi		116	600	
		Mumbai	Mumbai Central	283	700	
		Thane		260	500	
		Panvel		286	830	
		Pune		403	1200	
		Nashik		215	450	
Navsari		Mumbai	Mumbai Central	255	600	
Valsad		Mumbai	Mumbai Central	202	600	
Vapi		Mumbai	Mumbai Central	173	500	
Mumbai	Mumbai Central	Panvel		44	440	
		Pune		161	400	
		Nashik		169	700	
	Sion Circle	Panvel		31	400	

Source: JICA Study Team

(4) HSR Fare

Comparing the service level of HSR with other transport modes, four alternatives of fare for HSR is assumed, namely, 1) average fare of 2A and 3A 2) same fare level as 1A class of existing railway, 3) 1.5 times of 1A class fare, and 4) 2.0 times of 1A class fare.

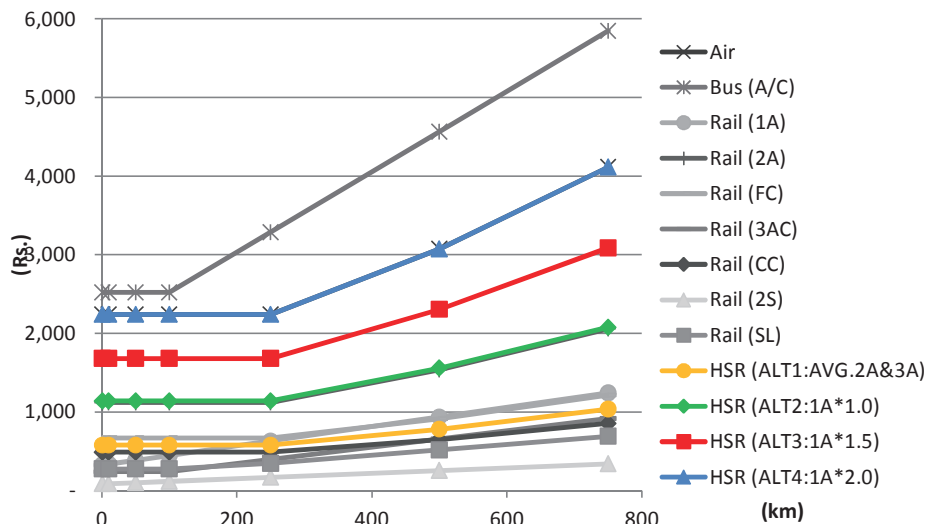

Source: JICA Study Team

Figure 5.2-4 Alternatives of HSR Fare and Fare of Other Transportation Modes

(5) Comparison of HSR Fare

1) Fare Comparison as of 2014

Following figure shows the fare for High Speed Railway for 500km in INR by country as of 2014. As shown in the figure, the fare for the case of 1.5 times as much as the fare for railway in 1A class in India is nearly equal to the fare in China.

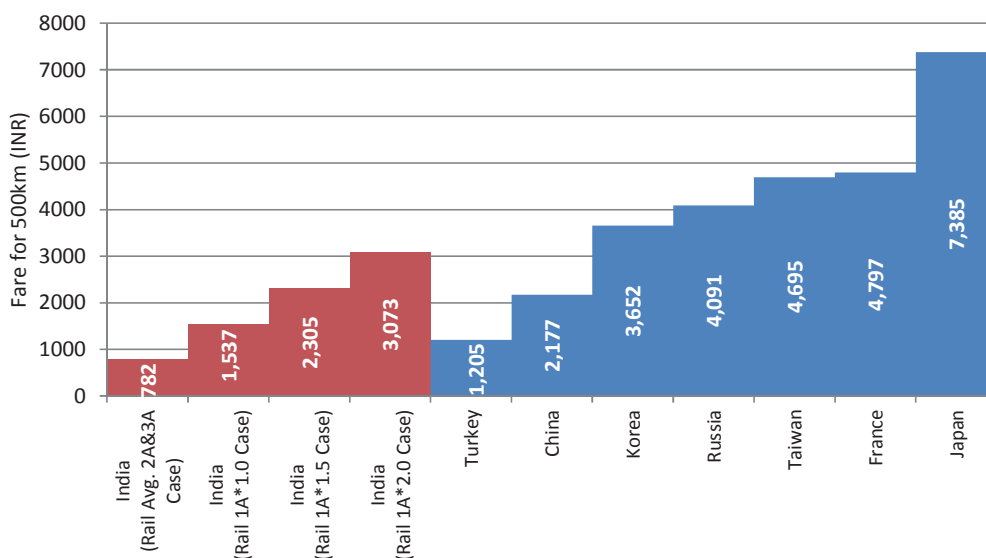

Source: JICA Study Team

Figure 5.2-5 Comparison for Fare for 500km



2) Fare Comparison in the Year of Opening

In the case of 1.5 times of 1A class fare, the rate of fare for HSR in GDP per capita<sup>5</sup>, Rs.270,240, is 0.85 percentages in 2023, opening year of HSR.

Comparing with the other countries, the rate is lower than Japan and higher than Korea and Taiwan.

**Table 5.2-4 Fare Comparison in the Year of Opening**

Country	India	Japan	Korea	Taiwan
Route	Mumbai-Ahmedabad	Tokyo-Osaka	Seoul-Busan	Taipei-Zuoying
Route length in km	500 km	500 km	412 km	345 km
One-way fare in the year of service opening	2,305 INR	3,000 Yen	44,800 Won	1,490 NT\$
Average fare for 500km as percentage of GDP per Capita	0.85 (2023)	1% (1964)	0.32 % (2004)	0.38 % (2007)

Source: JICA Study Team, Dr. Morichi

### 5.2.3 Recommendation

In this section, income level, fare level for HSR in other countries and fare system for other transportation modes in India are studied. Considering the facts, following strategies are recommended for HSR fare system:

#### (1) Seasonal Flexibility

Traffic demand is fluctuated by season or events along the target corridor. Considering the demand fluctuation, the fare for other transportation mode is fluctuated by season. To compete with other transportation modes, HSR fare also should be flexible by season. Also, air charter service and extra train service is provided in high seasons with high fare rate. As for HSR, an extra train should be operated in high season with high fare rate. On the other hand, the discount ticket should be provided in off-season to stabilize the traffic demand.

#### (2) Time Flexibility

Traffic demand is also effected by operation time since traffic is generated based on the human activity. Air ticket price is different by departure time even for same section based on the demand. The air fare for early morning and midnight flight is cheaper than the air ticket in working hour. To compete with air transport, the fare for HSR in off-peak hour also should be discounted.

#### (3) Discount for Early Booking

Stable traffic demand is the key factor for stable management. To stabilize the demand, discount ticket for advance booking is provided by air operators. HSR system also should be considered the early reservation discount.

---

<sup>5</sup> Nominal GDP. The GDP deflator is assumed at 105 – 107 per year.

### 5.3 Review of Travel Demand Forecast

#### 5.3.1 Principles for the Review of Demand Forecast

Passenger demand is forecasted based on the conventional four-step estimation method.

Firstly, base year OD among traffic analysis zones (TAZs) is captured based on the traffic survey and secondary transport statistics.

To estimate the future total traffic volume along the HSR line, the expansion factor is estimated based on the relationship between the serial traffic volume along the HSR line and the serial economic growth rate. The estimated total future trip is allocated to each TAZ based on the trip generation / attraction model, liner regression model between the trip generation volume as 2014 and the population of each TAZ. The future trip distribution is estimated based on the frater method based on the base year trip pattern. To estimate the modal share of trips from one TAZ to another TAZ, the multinomial logit model which is developed based on the traffic survey is applied. The model estimates the probability of modal choice with the travel cost and travel time between each zone. In this process, the multi fare level for HSR is applied to estimate the appropriate fare level.

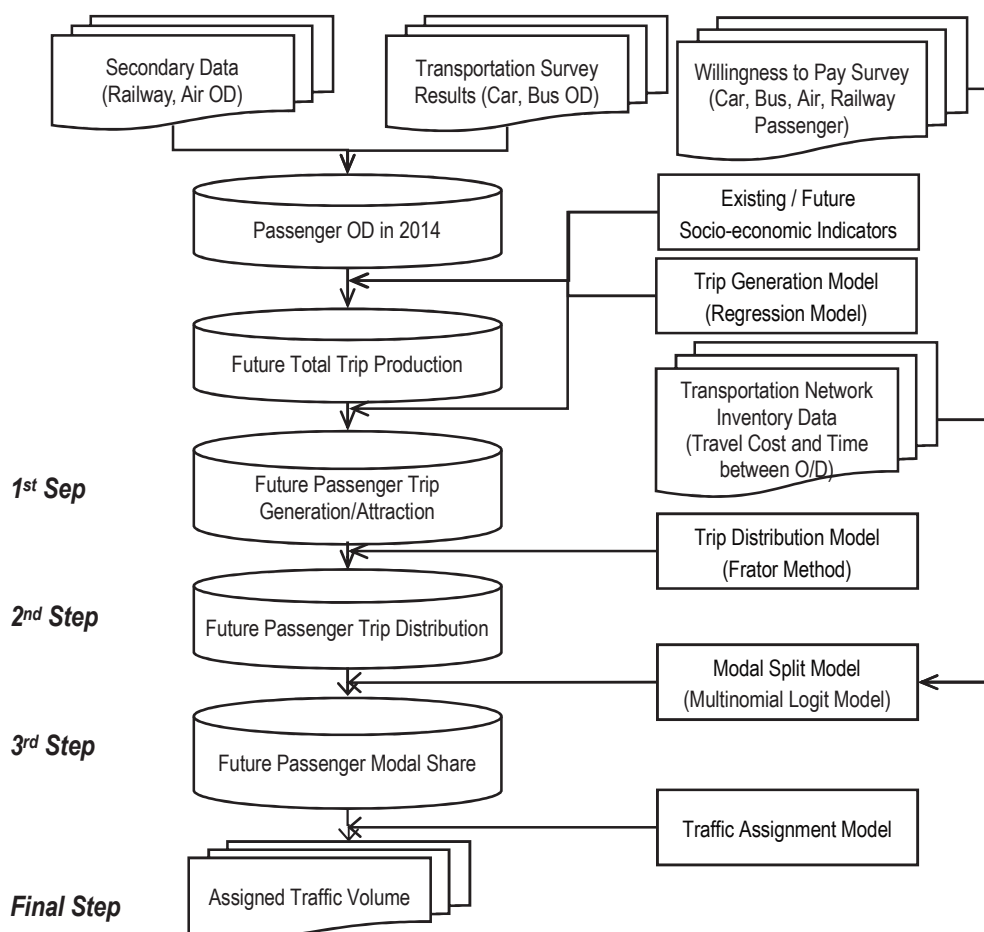

Figure 5.3-1 Demand Forecast Work Flow

### 5.3.2 Precondition for Demand Forecast

#### (1) Target Year

Transport demand is forecasted until the time horizon of 2053 commencing with the year 2023 and at intervals of 10 years.

#### (2) Zone System

The survey result shows that more than 99 % of the passenger at Ahmedabad, Vadodara, Surat and Mumbai comes from the accessible area within one hour. Considering the access and egress speed, the target area for demand forecast, Project Influenced Area (PIA), is set as the districts within approximately 60 kilometer from the planned HSR line.

The target area is divided into 66 traffic analysis zones (TAZ) based on the administrative boundary and geographic features, which is used as a reference for traffic data collection, analyses, and transport modelling. The TAZ is basically based on the district boundary. Some districts along the HSR line are further divided into one or some sub district area. Furthermore, the MMR and Ahmedabad city are divided into ten and six TAZs respectively in order to capture traffic demand in a more detailed manner, that is, traffic generation from the old Mumbai area and residential suburbs.

In addition to the 66 intra zone system, external zones (zone no. 67 - 82) are identified in order to capture the traffic movement between target area and the surrounding regions. In the external zones, Delhi is assumed as a special traffic analysis zone, zone no. 82 since the traffic volume is large.

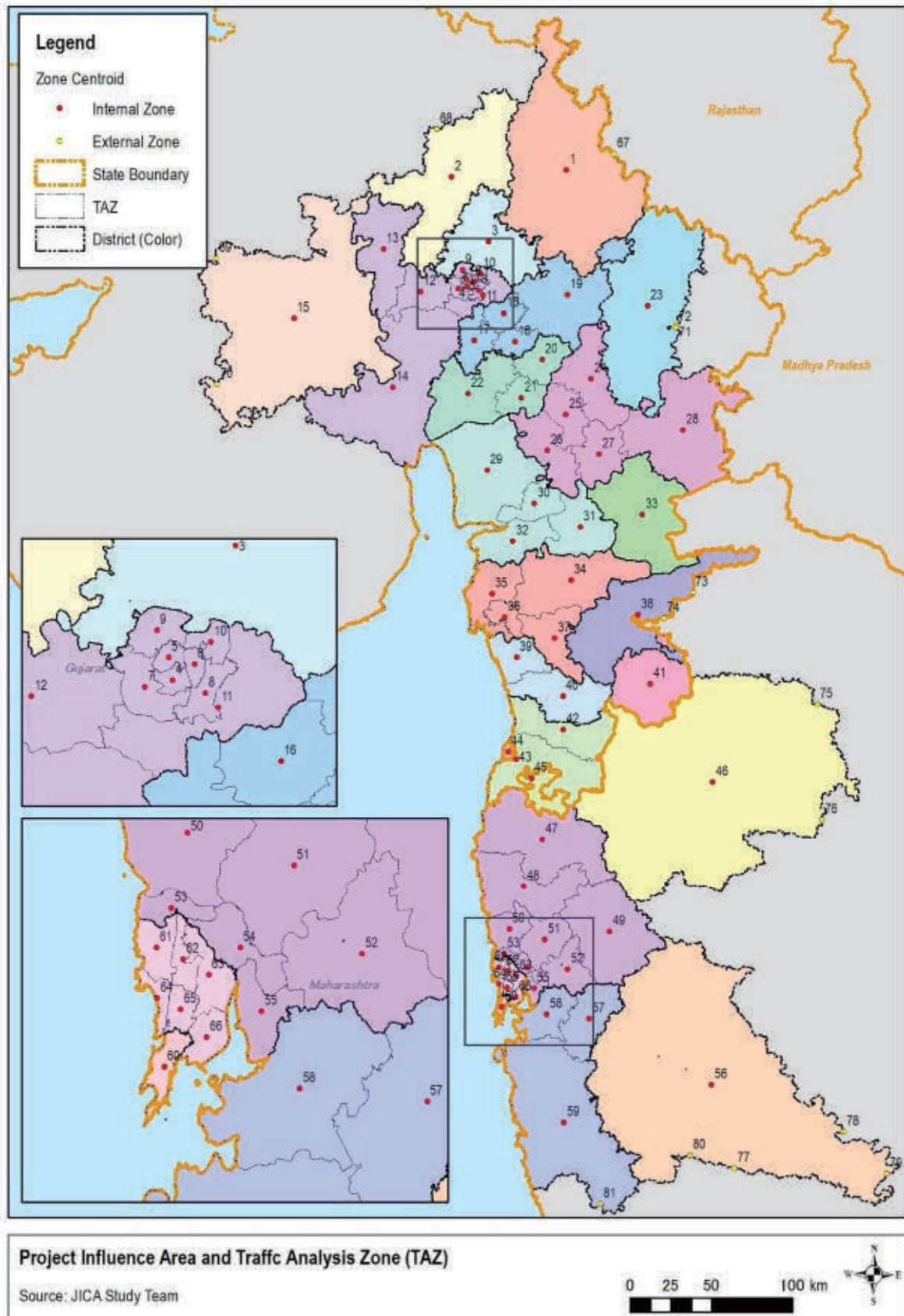

Figure 5.3-2 Traffic Analysis Zone System



### 5.3.3 Socio-economic Framework

#### (1) Population

For the long-term projection of future population, the population for the whole of India is forecasted in “World Population Prospects” (United Nations (UN), 2012). The population by state is forecasted in “Population Projections for India and States 2001-2026” (Office of the Registrar General & Census Commissioner, India (ORG & CCI), 2007) and “The Future Population of India” (Population Foundation of India and Population Reference Bureau (PFI & PRB), 2008).

PFI & PRB estimates future population until 2050 based on the cohort method and the result of censuses 2001 in India. On the other hand, the estimate by UN in 2012 is reflected the recent trend of fertility ratio, mortality ratio and so on. UN estimates the future population of India by 2100. In this study, it is assumed that the growth ratio of future population of whole India is the average of growth ratios those are estimates by UN and PFI & PRB.

The estimated population of whole India is further broken down to the state population, the district population and TAZ population.

The share of population of each state in whole India is assumed as the same share which is estimated by PFI & PRB since the estimate is considering the difference of growth ratio by state. The share of district population and TAZ population in each state is assumed as the same ratio as of 2011.

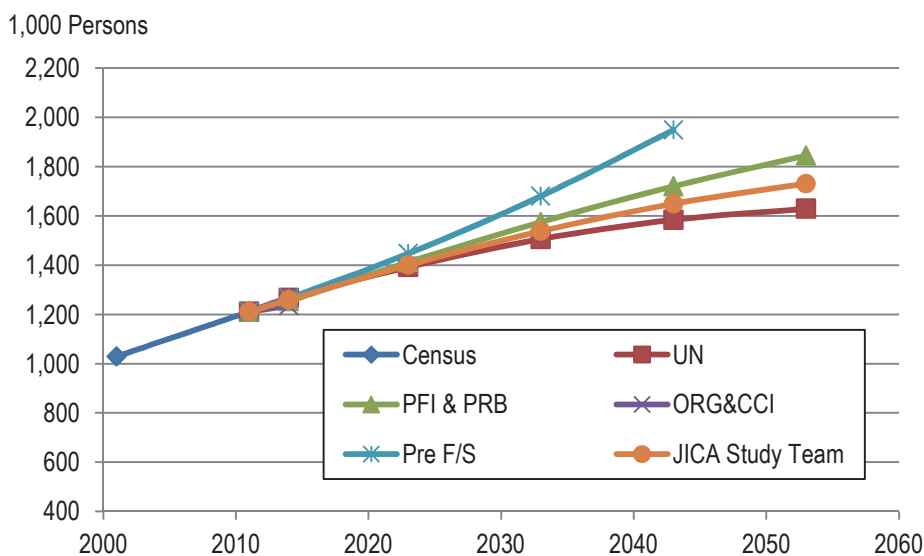

Note: The forecasted population for the Pre-Feasibility study (Pre F/S) is estimated by the JICA study team based on the annual growth rate of 1.5% which is stated in the pre F/S report.

Figure 5.3-3 Forecast of India's Population

Table 5.3-1 Projected Population by District

Unit: 1,000 persons

State	District	2011	2014	2023	2033	2043	2053
Gujarat	Mahesana	2,035	2,097	2,273	2,450	2,575	2,655
	Sabar Kantha	2,429	2,502	2,713	2,924	3,073	3,168
	Gandhinagar	1,392	1,434	1,555	1,675	1,761	1,816
	Ahmadabad	7,214	7,432	8,058	8,685	9,130	9,411
	Surendranagar	1,756	1,809	1,962	2,114	2,223	2,291
	Anand	2,093	2,156	2,338	2,519	2,648	2,730
	Kheda	2,300	2,369	2,569	2,769	2,910	3,000
	Panch Mahals	2,391	2,463	2,670	2,878	3,025	3,119
	Vadodara	4,166	4,292	4,653	5,015	5,272	5,434
	Narmada	590	608	659	711	747	770
	Bharuch	1,551	1,598	1,732	1,867	1,963	2,023
	The Dangs	228	235	255	275	289	298
	Navsari	1,330	1,370	1,485	1,601	1,683	1,735
	Valsad	1,706	1,757	1,905	2,053	2,159	2,225
	Surat	6,081	6,265	6,793	7,321	7,696	7,933
Tapi	807	831	901	971	1,021	1,053	
Daman & Diu	Daman	191	195	209	245	280	321
Dadra & Nagar Haveli	Dadra & Nagar Haveli	344	363	376	441	504	577
Maharashtra	Nandurbar	1,648	1,709	1,885	2,044	2,168	2,255
	Dhule	2,051	2,127	2,345	2,543	2,698	2,806
	Nashik	6,107	6,333	6,982	7,573	8,034	8,356
	Pune	9,429	9,778	10,781	11,693	12,405	12,901
	Mumbai	3,085	3,200	3,528	3,826	4,059	4,221
	Mumbai (Suburban)	9,357	9,703	10,698	11,603	12,310	12,802
	Thane	11,060	11,469	12,645	13,716	14,550	15,132
	Raigarh	2,634	2,732	3,012	3,267	3,465	3,604
	Solapur	4,318	4,478	4,937	5,354	5,680	5,907
	Satara	3,004	3,115	3,434	3,725	3,952	4,110
	Sangli	2,822	2,927	3,227	3,500	3,713	3,861

Source: 2011 censuses. The values after 2014 were estimated by the JICA study team .

## (2) GDP

The long term GDP forecast up to 2050 was conducted in the “Global Economics Paper” (Goldman Sachs 2007). IMF also forecasted the GDP up to 2018 in the “World Economic Outlook” (IMF 2013). On the other hand, the target growth ratio in the Twelfth Plan for government of India is 8.0 percent up to 2018.

Considering the recent economic stagnation in India, the growth rate of GDP up to 2018 is assumed as the IMF estimate. After 2019, the growth rate is assumed as the Goldman Sachs estimates as shown in Table 5.3-2.

The share of GDP of Gujarat state and Maharashtra state in the GDP of whole India is assumed as same rate as of 2011.

Table 5.3-2 Forecasted GDP AAGR in India

Unit: %

	2011 - 2012	2012 - 2015	2015 - 2020	2020 - 2025	2025 - 2030	2030 - 2035	2035 - 2040	2040 - 2045	2045 - 2050	2050 - 2052
Central Statistics Office	3.24									
IMF		5.07	6.64 <sup>6</sup>	-	-	-	-	-	-	-
Goldman Sachs		6.60	5.90	5.90	6.00	6.00	5.90	5.60	5.20	-
12th Plan		8.00	8.00 <sup>7</sup>	-	-	-	-	-	-	-
JICA Study Team	3.24	5.07	6.33	5.90	6.00	6.00	5.90	5.60	5.20	5.20

Source: World Economic Outlook (IMF 2013), Global Economics Paper (Goldman Sachs, 2007), Twelfth Plan (Government of India)

Table 5.3-3 Forecasted GDP

Unit: Billion Rupees (Constant Price at 2004)

	2014	2023	2033	2043	2053
Gujarat	4,494	7,709	13,780	24,284	40,624
Maharashtra	8,872	15,217	27,200	47,936	80,188
India	59,080	101,337	181,138	319,221	534,006

Source: JICA Study Team

Table 5.3-4 Forecasted GDP per Capita

Unit: Rupees / Person (Constant Price at 2004)

	2011	2014	2023	2033	2043	2053
Gujarat	65,999	72,173	114,189	189,395	317,496	515,226
Maharashtra	70,070	76,133	118,441	195,186	324,253	521,562
India	43,315	46,935	72,372	117,784	193,622	308,418

Source: JICA Study Team

### 5.3.4 Transportation Networks

#### (1) Base Year Transport Network

The year 2014 base year transport network is developed based on the geographic information from google earth, DIVA-GIS and private mapping companies in India. The data was reviewed and updated based on the maps, the route information from state governments and central government and site investigation by the JICA Study Team.

Four major transportation modes are available along the HSR line, namely railway (Western Railway and Central Railway), bus, private car (NH8) and air.

#### (2) Future Transport Network

There are various kinds of transport projects along the HSR line. Especially among them, following projects are major and tangible projects which should be considered to plan the HSR.

<sup>6</sup> Estimate by 2018

<sup>7</sup> Estimate by 2017

Table 5.3-5 Major Transportation Project along the HSR Line

Sector	Name	Origin	Destination	Distance (km)	Target Year
Road	Vadodara - Mumbai Expressway	Vadodara	Mumbai	380	
Rail	Mumbai Metro Line 1	Versova	Ghatkopar	11.4	2015
	Mumbai Metro Line 2	Charkop	Mankhurd	31.87	Re-planned
	Mumbai Metro Line 3	Cuffe Parade	SEEPZ	32.5	2020
	Mumbai Monorail Phase1	Chembur	Wakade	8.93	2014
	Mumbai Monorail Phase2	Wakade	Gadge Maharaj Chowk	11.2	2015
	MEGA North South Line	APMC	Motera Stadium	14.8	2019
	MEGA East West Line	Vastral Gem	Thaltej	20.4	2019



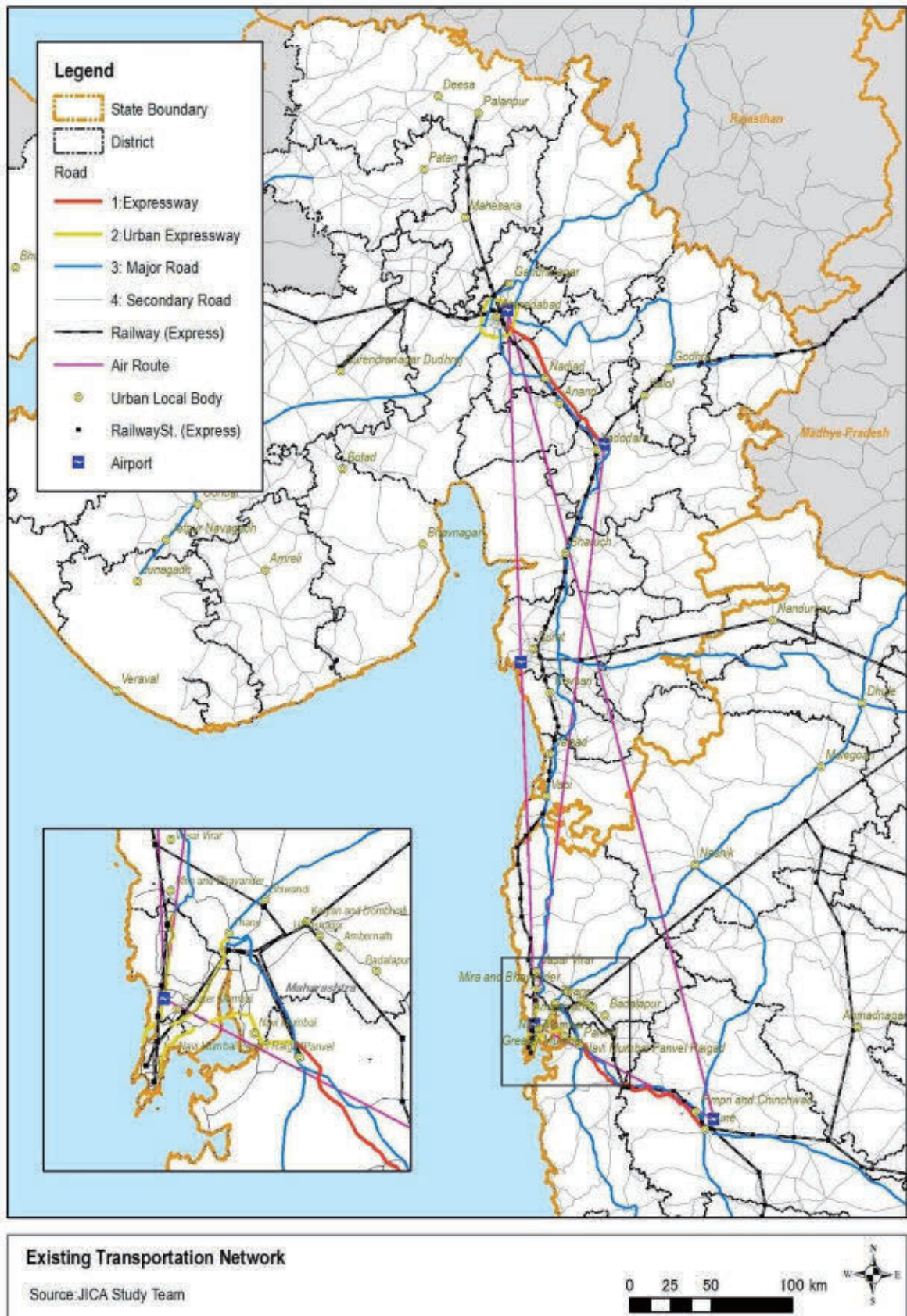

Figure 5.3-4 Existing Transportation Network



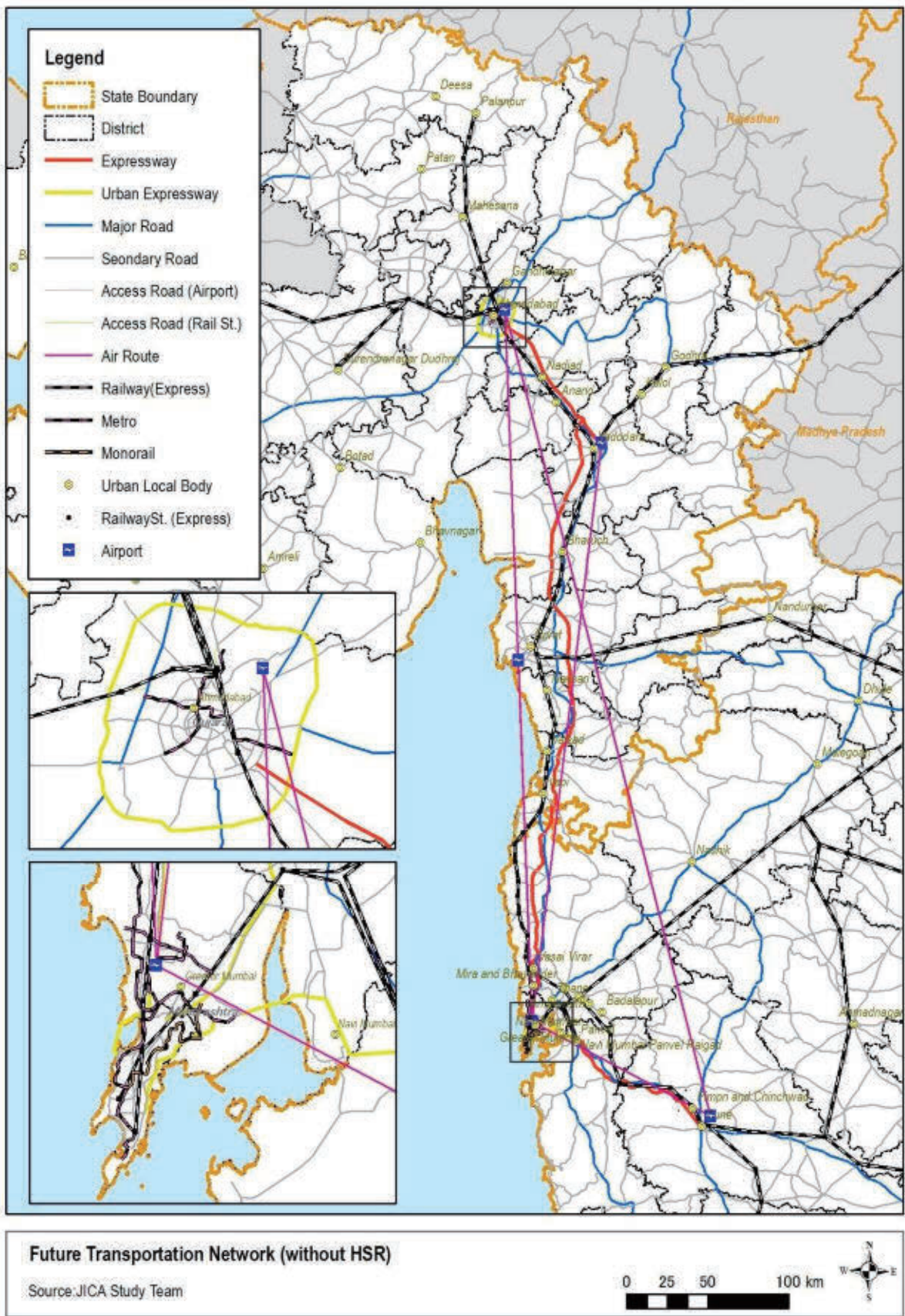

Figure 5.3-5 Future Transportation Network

### 5.3.5 Base Year Origin-Destination (OD) Development

#### (1) Air

Table 5.3-6 shows the air passenger OD in 2012 which includes the passenger volume to / from Delhi as well as the passenger volume within PIA. As shown the table, high passenger volume is observed among Mumbai, Ahmedabad and Delhi. Figure 5.3-6 shows the past trend of total air passengers at five airports within PIA. The annual average growth rate of air passenger from 2004 to 2012 is 15 percent. With the growth rate, air passenger OD in base year, 2014, is developed as shown in Table 5.3-7. Within the PIA, total daily passenger volume estimated at approximately 4,700 passengers.

Table 5.3-6 Air Passenger OD in 2012

	Ahmedabad	Vavodara	Surat	Mumbai	Total
Ahmedabad	0	0	0	1,296	1,296
Vavodara	0	0	0	532	532
Surat	0	0	0	97	97
Mumbai	1,269	516	69	0	1,854
<b>Total</b>	<b>1,269</b>	<b>516</b>	<b>69</b>	<b>1,925</b>	<b>3,779</b>

Unit: Passenger / day

Source: DGCA

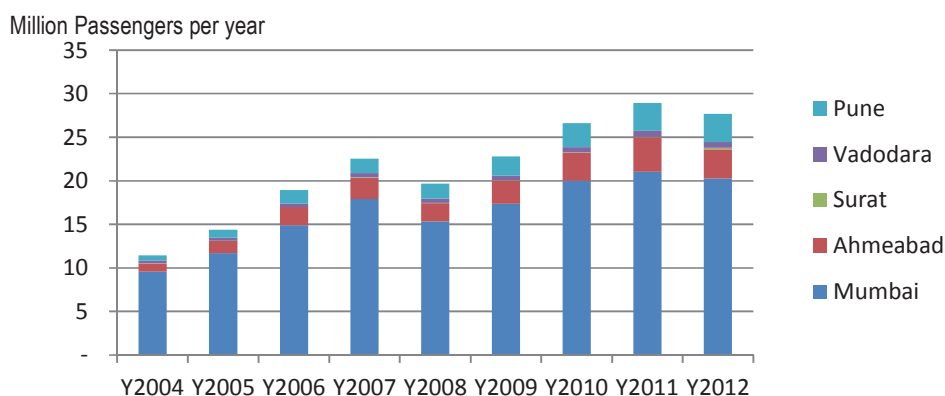

Figure 5.3-6 Air Passenger Trend

Table 5.3-7 Estimated Air Passenger OD in 2014

	Ahmedabad	Vavodara	Surat	Mumbai	Total
Ahmedabad	0	0	0	1,616	1,616
Vavodara	0	0	0	663	663
Surat	0	0	0	121	121
Mumbai	1,582	643	86	0	2,311
<b>Total</b>	<b>1,582</b>	<b>643</b>	<b>86</b>	<b>2,400</b>	<b>4,711</b>

Unit: Passenger / day

Source: JICA Study Team

#### (2) Railway

The railway passenger OD for A/C class in 2013 is provided by the Center for Railway

Information Systems, the organization under the Ministry of Railway. With the OD data and growth rate based on the past trend, the railway passenger OD in 2014 is estimated.

Within the PIA, average daily passenger is estimated at approximately 18 thousand passengers.

Table 5.3-8 A/C Railway Passenger OD in 2014

Unit: Passenger / day

Area No.	1	2	3	4	5	Total
1	23	131	816	2,977	416	4,363
2	121	35	292	1,414	80	1,942
3	788	307	66	1,674	57	2,892
4	3,164	1,397	1,943	26	953	7,483
5	403	56	38	932	55	1,484
Total	4,499	1,926	3,155	7,023	1,561	18,164

Source: JICA Study Team

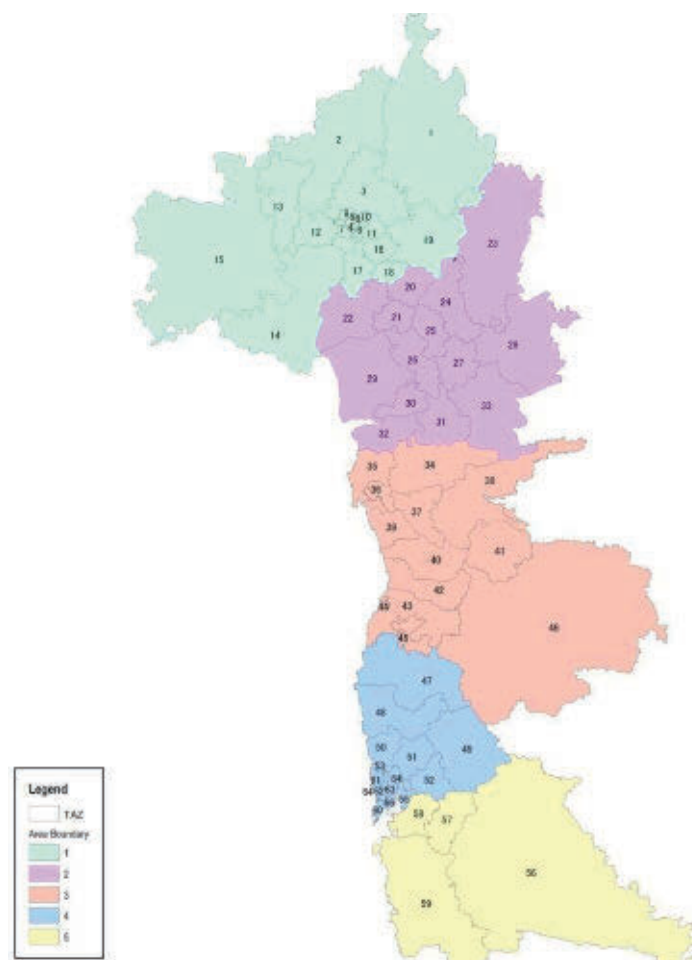

Figure 5.3-7 TAZ and Area Boundary

### (3) Bus

The A/C bus passenger OD is developed based on the terminal survey in this study. With the average occupancy rate by route and the frequency data of bus operation, the OD is estimated within the PIA. Within the PIA, average daily bus passenger is estimated at approximately 32 thousand passengers.

Table 5.3-9 A/C Bus Passenger OD in 2014

Unit: Passenger / day

Area No.	1	2	3	4	5	Total
1	132	1,165	1,422	1,689	1,024	5,431
2	1,164	108	761	2,248	624	4,906
3	1,419	762	753	2,885	750	6,569
4	1,688	2,248	2,885	0	2,584	9,406
5	1,019	624	748	2,584	0	4,974
Total	5,422	4,906	6,569	9,406	4,982	31,286

Source: JICA Study Team

### (4) Private Vehicle

The private vehicle OD is developed based on OD interview survey and corresponding traffic count survey along the HSR corridor in this study. Within the PIA, average daily private vehicle passenger is estimated at approximately 100 thousand passengers.

Table 5.3-10 Private Vehicle OD in 2014

Unit: Passenger / day

Area No.	1	2	3	4	5	Total
1	2,042	5,827	10,142	4,823	1,395	24,229
2	8,318	4,061	6,784	3,860	1,188	24,211
3	11,734	6,568	3,529	6,382	1,762	29,975
4	4,271	3,165	4,655	2,176	720	14,987
5	3,251	1,949	1,767	74	0	7,041
Total	29,616	21,570	26,877	17,315	5,065	100,443

Source: JICA Study Team

### (5) Modal Share

Figure 5.3-8 shows the current modal share of inter-zonal trips within PIA. Car trip is the dominant transportation.

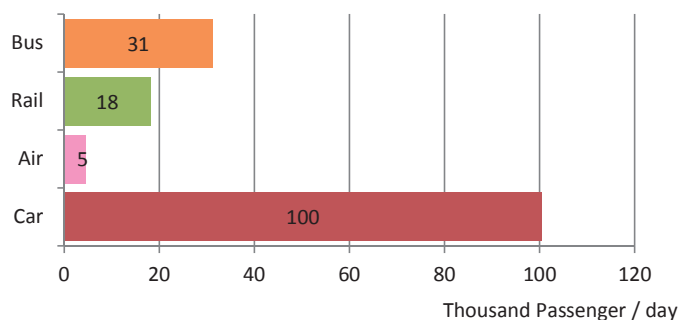

Source: JICA Study Team

Figure 5.3-8 Modal Share within PIA in 2014



### 5.3.6 Trip Production

#### (1) Trip Production Model

Trip production is the total trip volume within the project influenced area (PIA). The future trip production is estimated by existing total trip production within the PIA and the expansion factor calculated by future GDP growth rate and elasticity of trip volume to GDP. It is assumed that the elasticity of trip production to GDP in PIA is same as the factor of the passenger volume in Western railway and Central railway to the sum of GDP in Maharashtra and Gujarat between 2005 and 2012 since there were no major transportation projects during the time within the PIA which induce the drastic modal shift<sup>8</sup>. The elasticity is estimated at 1.095 (R<sup>2</sup>=0.95).

**Table 5.3-11 Past Trend of GDP and Railway Passenger Volume**

Year	GDP(Crore Rupee)	Railway Passenger	GDP Growth Rate (from 2005)	Railway Pax. Growth Rate (from 2005)
2005	704,705	2,402,892	-	-
2006	788,047	2,830,498	11.83%	17.80%
2007	876,105	2,944,633	24.32%	22.55%
2008	910,532	3,398,090	29.21%	41.42%
2009	1,001,060	3,638,115	42.05%	51.41%
2010	1,102,752	3,798,973	56.48%	58.10%
2011	1,186,310	4,108,300	68.34%	70.97%

Note: GDP: The Sum of GDP in Gujarat and Maharashtra states. The GDP is constant price at 2004. Railway passenger: The passenger volume for non-suburban trains in Western Railway.

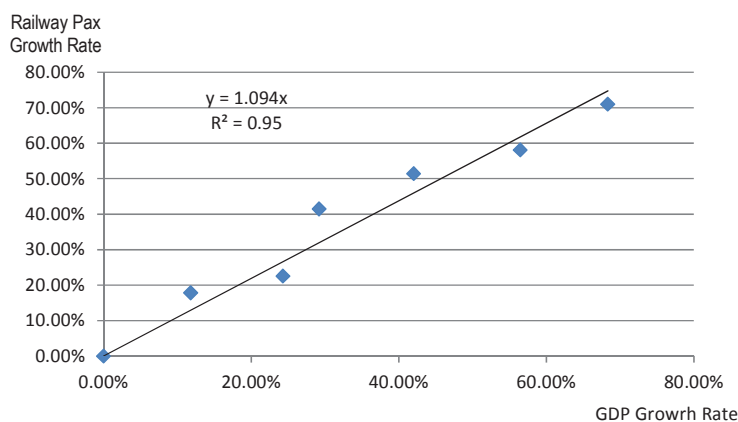

**Figure 5.3-9 Past GDP Growth Rate and the Growth Rate of Railway Passenger Volume**

#### (2) Future Trip Production

Based on forecasted future GDP and the elastic factor, future total trip production is forecasted. In 2053, trip production is expected to 9.79 times of trip production in 2014.

<sup>8</sup> The complete long-term OD data and economic growth data within the PIA isn't available. Only the long-term, total passenger volume within the Western and the past GDP data by state are available. As for the GDP in Gujarat, only the GDP data by state is available.

Table 5.3-12 Future Trip Production in PIA

Year	GDP ('000 Rs. Const Price in 2004)	GDP Growth Rate	Trip Growth Rate	Trip Production (PIA) '000
2014	1,336	100%	100%	153
2023	2,292	172%	178%	273
2033	4,098	307%	326%	499
2043	7,222	540%	582%	891
2053	12,081	904%	979%	1,501

### 5.3.7 Trip Generation / Attraction

#### (1) Trip Generation / Attraction Model

As mentioned above, total trip volume within PIA is estimated based on the future GDP growth rate and elasticity of trip volume to GDP. To consider the regional difference of trips generation, trip generation/attraction model is applied. For the trip generation/attraction model, zonal population is adapted as explanatory variables in the following equation. Comparing other TAZs, the rate of trip volume to population in Mumbai city area is relatively high. Therefore, Mumbai city dummy variables are adapted. The difference between the estimated total sum of trip attraction / generation and trip production is adjusted.

$$G_i = 0.9731 \cdot POP_i + 18,532.77 \cdot dum_i + 1,686.33$$

$$A_i = 1.0613 \cdot POP_i + 18,595.25 \cdot dum_i + 1,400.74$$

where,  $G_i$ : Future trip generation at zone i,  
 $A_i$ : Future trip attraction at zone i,  
 $POP_i$ : Future population at zone I (Unit:000),  
 $dum_i$ : Dummy at Mumbai City,

Table 5.3-13 Trip Generation/Attraction Model

Variables	Generation Model		Attraction Model	
	Coefficient	t-value	Coefficient	t-value
Constant	1,686.33	5.04	1,400.74	5.30
Population	0.9731	5.37	1.0613	7.43
Dummy	18,532.77	8.77	18,595.25	11.15
Correlation Coefficient	0.88		0.88	
Number of Samples	66		66	

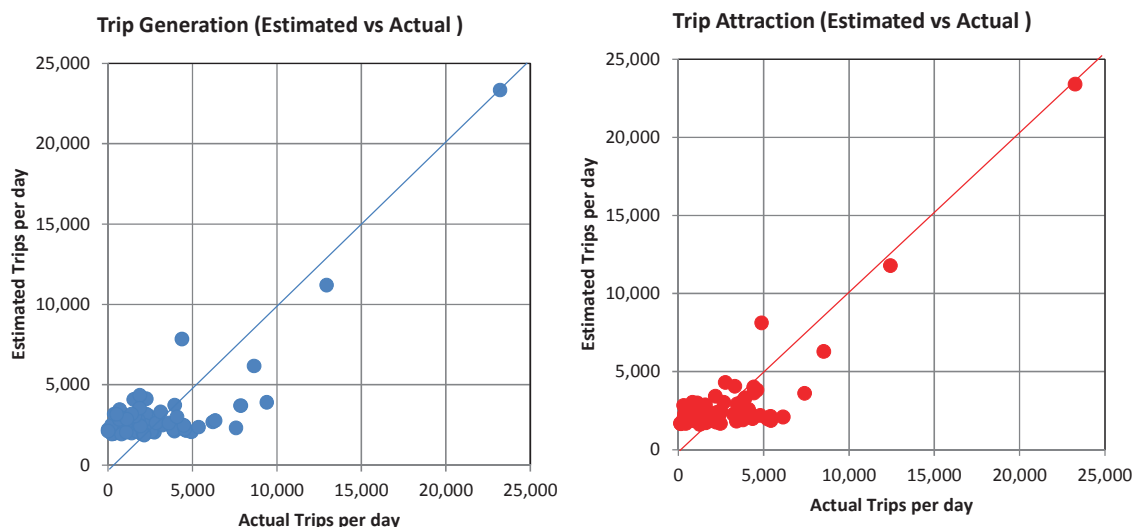

Source: JICA Study Team

Figure 5.3-10 Comparison between Estimated Trips and Actual Trips

Table 5.3-14 Future Trip Generation / Attraction (2014 – 2053)

Unit: '000 Trips / day

Area No.	2014	2023	2033	2043	2053
1	49	86	157	279	468
2	34	60	109	194	325
3	38	69	126	226	381
4	69	122	223	397	669
5	19	34	64	117	199

Source: JICA Study Team

### 5.3.8 Trip Distribution

#### (1) Trip Distribution Model

The person trip distribution for inter zone travel is estimated by the Frater method, as shown in following formula.

$$T_{ij} = t_{ij} \cdot \frac{G_i}{g_i} \cdot \frac{A_j}{a_j} \cdot \frac{1}{2} \left( \frac{g_i}{\sum_j t_{ij} \cdot A_j / a_j} + \frac{a_j}{\sum_i t_{ij} \cdot G_i / g_i} \right)$$

- where,
- $T_{ij}$ : Future trip distribution at zone i to j,
  - $G_i$ : Future trip production at zone i,
  - $A_j$ : Future trip attraction at zone j,
  - $t_{ij}$ : Current trip distribution at zone i to j
  - $g_i$ : Current trip production at zone i, and
  - $a_j$ : Current trip attraction at zone j

### 5.3.9 Modal Split

#### (1) Modal Split Model

Based on the willingness to pay survey, the multinomial logit model is developed to estimate the modal split. The proportion of trips between any two zones, i and j that choose Choice one out of the subset of two choices is given as:

$$P_{in} = \frac{\exp(V_i)}{\sum_j \exp(V_j)}$$

Where,  $P_{in}$  : Possibility of choosing transportation mode i

$$V_i = \beta_1 Z_{1i} + \beta_2 Z_{2i} + \dots + \beta_k Z_{ki} + Const$$

$V_i$  : Utility function of transportation mode i (time and cost)

$Z_{ki}$  : Variable of each zone in relation to transportation mode i

$\beta_1$  : Parameter of explanatory variable 1

Table 5.3-15 Parameter of Modal Split Model

#### High Income

Variable	Travel Time	Travel Fare	Const1	Const2	Const3	Const4	Roh	Roh_bar	Hit-R(%)
HSR	-0.01364360	-0.00070004	-0.694215				0.335	0.335	60.4
Air				-0.515052					
Railway					-1.16995				
Car						0.967556			
Bus									
t-value	-26.6129	-20.2659	-4.281	-2.9469	-9.6597	10.9098			

#### Middle Income

Variable	Travel Time	Travel Fare	Const1	Const2	Const3	Const4	Roh	Roh_bar	Hit-R(%)
HSR	-0.01132150	-0.00095356	-0.199484				0.211	0.211	52.8
Air				0.669072					
Railway					-0.042663				
Car						0.446907			
Bus									
t-value	-46.4692	-47.0247	-2.6032	7.4655	-0.9444	11.0296			

#### Low Income

Variable	Travel Time	Travel Fare	Const1	Const2	Const3	Const4	Roh	Roh_bar	Hit-R(%)
HSR	-0.01050080	-0.00122391	-0.150898				0.200	0.200	48.0
Air				0.693299					
Railway					0.140765				
Car						-0.654998			
Bus									
t-value	-55.7761	-57.9075	-2.4437	8.3318	4.4742	-19.8395			

Where, High Income: Rs.150,000 or more,

Middle Income: Rs.60,000 or 149,999,

Low Income: Rs.59,999 or less,

Travel Time: Travel time (min) between zones,

Travel Fare: Travel Fare (Rs.) between zones,

Const: Constant Value



Following figure shows, the comparison of modal share between actual trips and estimated trips.

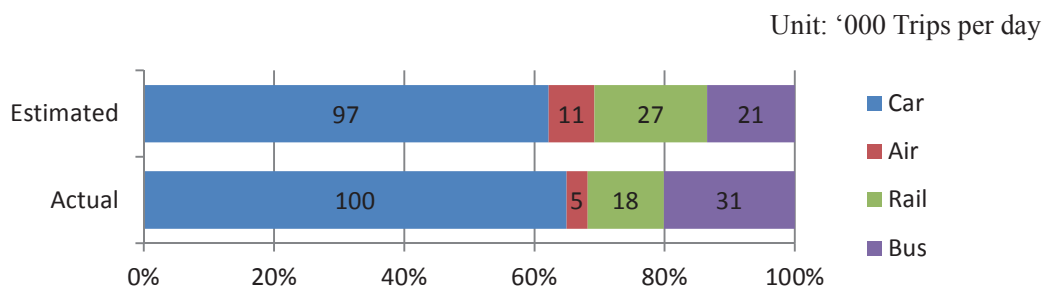

Source: JICA Study Team

Figure 5.3-11 Comparison between Estimated Trips and Actual Modal Share within PIA in 2014

## (2) Assumption of Service Level

### 1) Income Level

It is assumed that the income level of passenger implicates the modal choice. Figure 5.3-12 shows the distribution of household income by transportation mode. As shown in the figure, high income travelers prefer the high speed but high cost transportation mode.

To assume the modal split in the future, the distribution of income level is assumed as Table 5.3-16. It is assumed that the growth rate of income level is same as GDP per capita which was mentioned in Table 5.3-4.

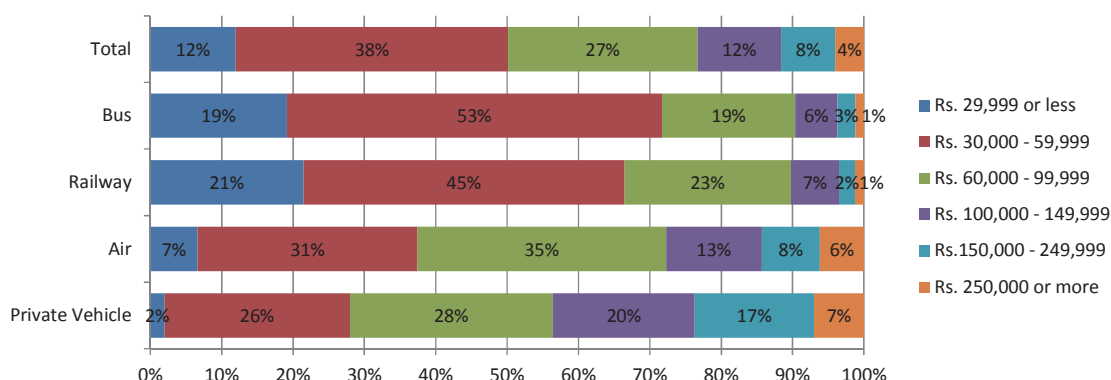

Source: JICA Study Team

Figure 5.3-12 Household Income Level by Transportation Mode in 2014

Table 5.3-16 Assumed Distribution of Household Income

	Y2014	Y2023	Y2033	Y2043	Y2054
High Class (Rs. 150,000 or more)	12%	26%	52%	82%	91%
Middle Class (Rs. 60,000 – 149,999)	38%	51%	38%	13%	5%
Low Class (Rs. 59,999 or less)	50%	23%	9%	6%	3%

2) Waiting Time

As shown in Figure 5.3-13 the waiting time is different from transportation mode. Based on the interview surveys at the terminals of each transport modes, the waiting time for air, railway and bus are assumed at 81 minutes, 24 minutes and 19 minutes, respectively. The waiting time for HSR is assumed as same as existing railway passenger, 24 minutes.

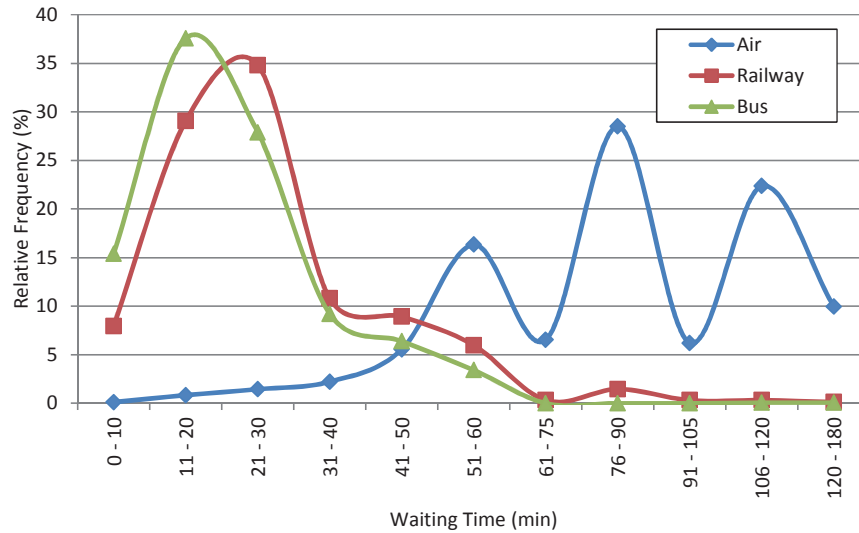

Source: JICA Study Team

Figure 5.3-13 Waiting Time Distribution by Transportation Mode

Table 5.3-17 Observed Waiting Time and Assumed Waiting Time

Waiting Time (min)	Air Passenger	Railway Passenger	Bus Passenger	HSR Passenger
Survey Result <sup>9</sup>	81	24	19	N/A
Assumed Time	81	24	19	24

Source: JICA Study Team

3) Access and Egress Transportation Mode

Figure 5.3-14 shows the access and egress transportation mode for bus, railway and air passengers. As shown in this figure, the dominant transportation mode for access and egress for railway and air passenger is private car. On the other hand, most of the bus passengers access/egress by auto rickshaw. Based the survey result, access/egress transportation mode is assumed as shown in Table 5.3-18. As for the HSR, it is assumed the HSR passenger will access/egress to the station by private car like as railway and air passenger.

<sup>9</sup> The time is taken from the 50<sup>th</sup> percentile level of cumulative frequency.

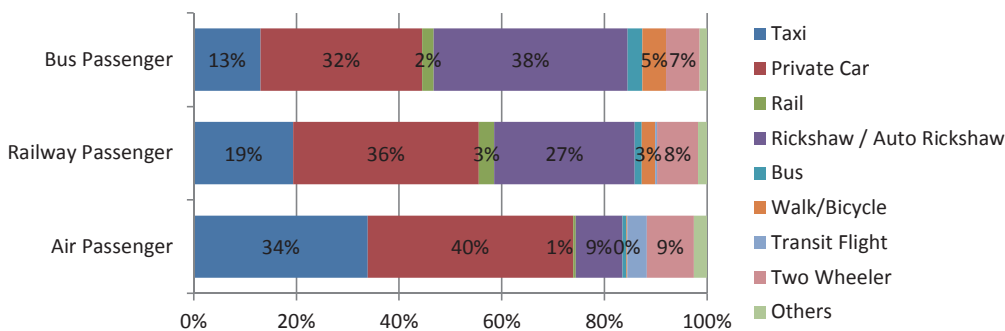

Source: JICA Study Team

Figure 5.3-14 Access / Egress Transportation Mode<sup>10</sup>

Table 5.3-18 Assumed Transportation Mode for Access and Egress

	Air Passenger	Railway Passenger	Bus Passenger	HSR Passenger
Assumed Access / Egress Transportation Mode	Private Car	Private Car	Auto Rickshaw	Private Car

Source: JICA Study Team

4) Access and Egress Time

In the transport demand forecast model, access / egress time shall be calculated by the transportation network model by each OD pair. Here, actual access / egress time is shown for the reference. Almost half of passengers access from the area where the passenger can access within 25- minute. 95 percent of the passengers access from the area within 60-minute drive.

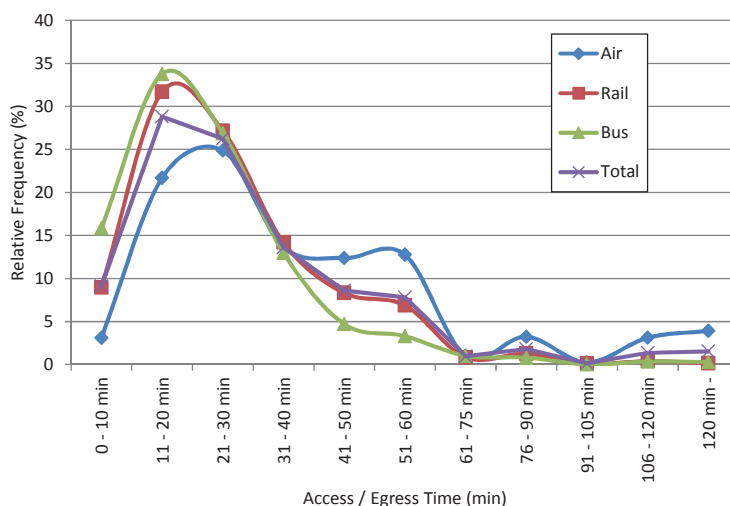

Source: JICA Study Team

Figure 5.3-15 Access / Egress Time Distribution by Transportation Mode

<sup>10</sup> Based on the surveyors, most of the passengers were picked-up or dropped-off by their family or company car at the terminals. “Others” in the figure shows two-wheelers or transit at the airport.

### 5.3.10 Traffic Assignment

#### (1) Analysis of HSR Traffic Demand

Following figures show the estimated total daily passenger volume and fare income for HSR by fare case.

As shown, fare income is to be maximized in the case of 1.5 times of 1A class fare of railway.

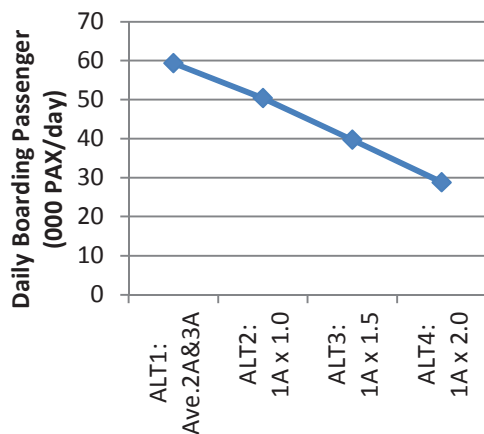

Source: JICA Study Team

Figure 5.3-16 Total Passenger Volume for HSR by Fare Case (2023)

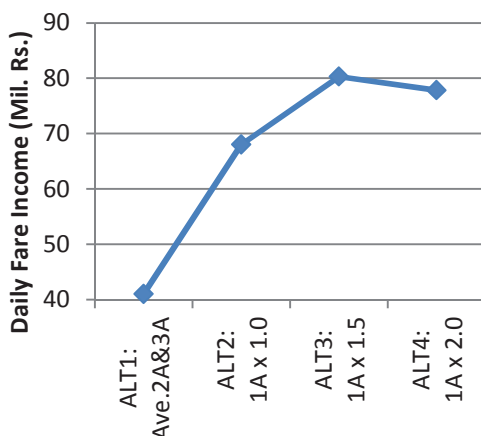

Source: JICA Study Team

Figure 5.3-17 Fare Income for HSR by Fare Case (2023)

Following figure shows the daily cross sectional traffic for HSR in 2023 and 2053 with Sabarmati new Station.

Total daily boarding passenger in 2023 and 2053 is estimated at 40 thousands passengers and 202 thousands passengers, respectively. Maximum sectional traffic volume in 2023 and 2053 is 36 thousand passengers and 186 thousand passengers, respectively.

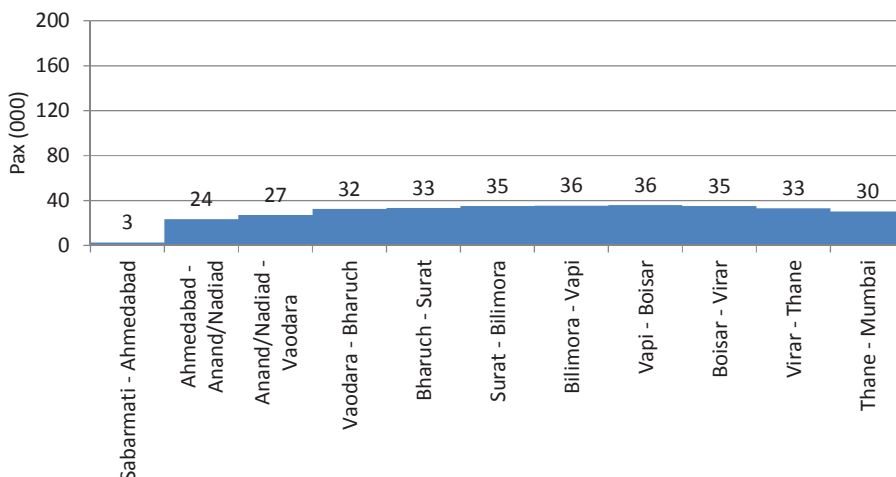

Figure 5.3-18 Cross Sectional Traffic for HSR in 2023 (1A\*1.5 Case: Two-ways)  
(With Sabarmati St. Case)

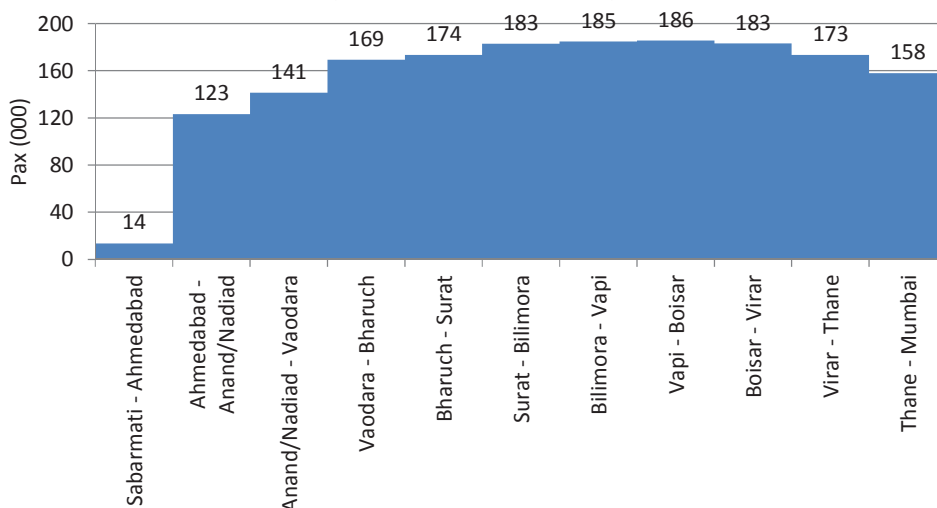

Figure 5.3-19 Cross Sectional Traffic for HSR in 2053 (1A\*1.5 Case: Two-ways)  
(With Sabarmati St. Case)

Table 5.3-19 Summary of Traffic Demand Forecast (1A\*1.5 Case: With Sabarmati St.)

Year	PAX ('000 Passenger / day)	Person*km <sup>11</sup> ('000)	Maximum Sectional Traffic Volume ('000 PAX /two ways)	Average Transport Density ('000 Person/day)
2023	40	16,083	36	32
2053	202	83,817	186	166

<sup>11</sup> Access/ Egress distance isn't included.



(2) Traffic Volume by Stations

Total HSR passenger volume for boarding and alighting in 2023 and 2053 was estimated. As shown the figure, it is estimated that daily passengers in 2023 from / to Ahmedabad and Mumbai station is 21,000 and 30,000, respectively. Following table show the station-to-station passenger OD for HSR.

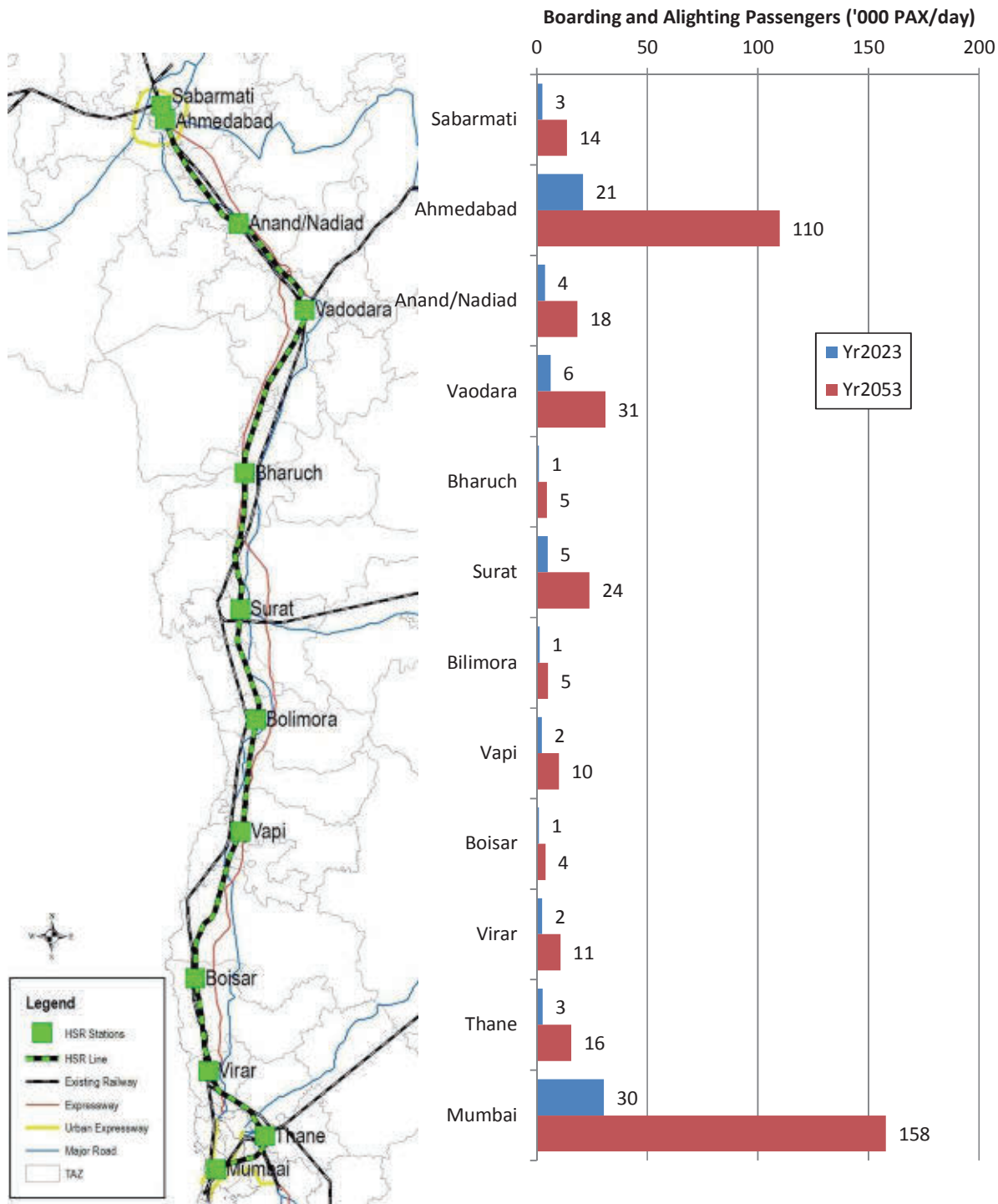

Figure 5.3-20 Boarding and Alighting Passenger for HSR in 2023 and 2053  
(1A\*1.5 Case: Total of Boarding and Alighting Passengers  
(With Sabarmati St. Case)

(3) Modal Share

Following figure shows the modal share within PIA of daily trips. It is estimated that HSR shared approximately 14 percentage of total traffic.

Unit: '000 Passenger / day

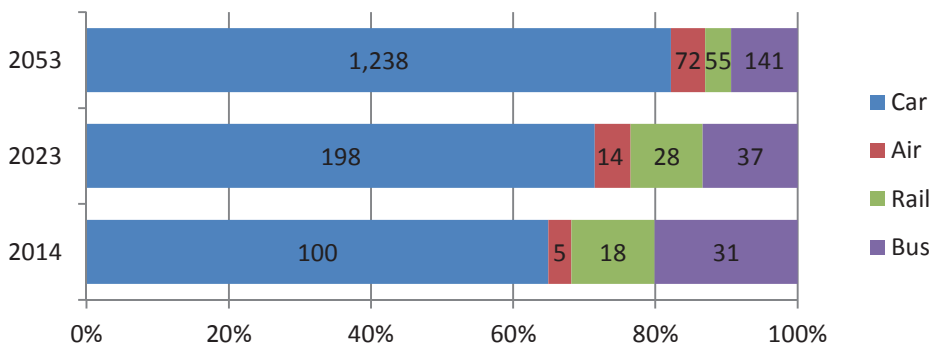

Figure 5.3-21 Modal Share within PIA (without Case)

Unit: '000 Passenger / day

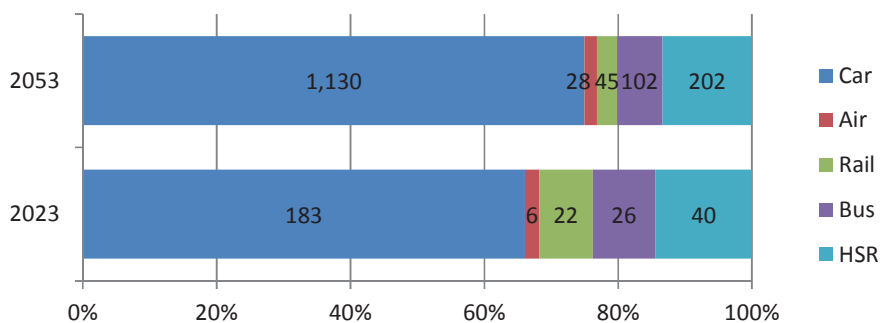

Figure 5.3-22 Modal Share within PIA (1A\*1.5, With Sabarmati St. Case )

(4) Project Impact Study

Following figure shows the modal share from Mumbai area to major cities.

Unit: '000 Passenger / day

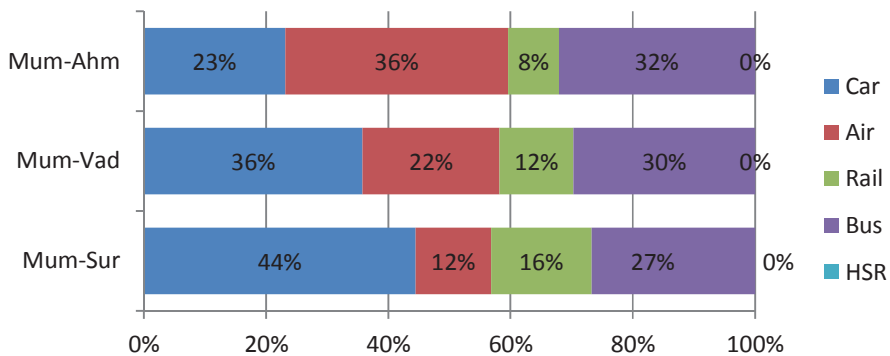

Figure 5.3-23 Modal Share for the Trips from Mumbai to Ahmedabad, Vadodara and Surat in 2023 (without Case)

Unit: '000 Passenger / day

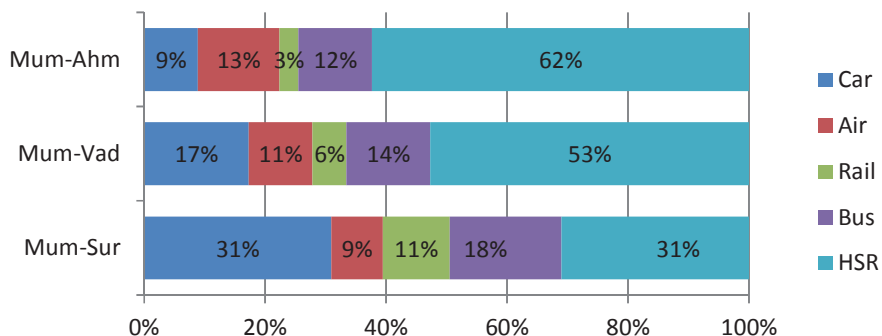

Figure 5.3-24 Modal Share for the Trips from Mumbai to Ahmedabad, Vadodara and Surat  
In 2023 (1A\*1.5, With Sabarmati St. Case )

Following figure shows the impact of HSR to the existing railway between Mumbai and Ahmedabad. It is estimated that approximately 4 thousand passenger will be shifted to HSR in average in 2023.

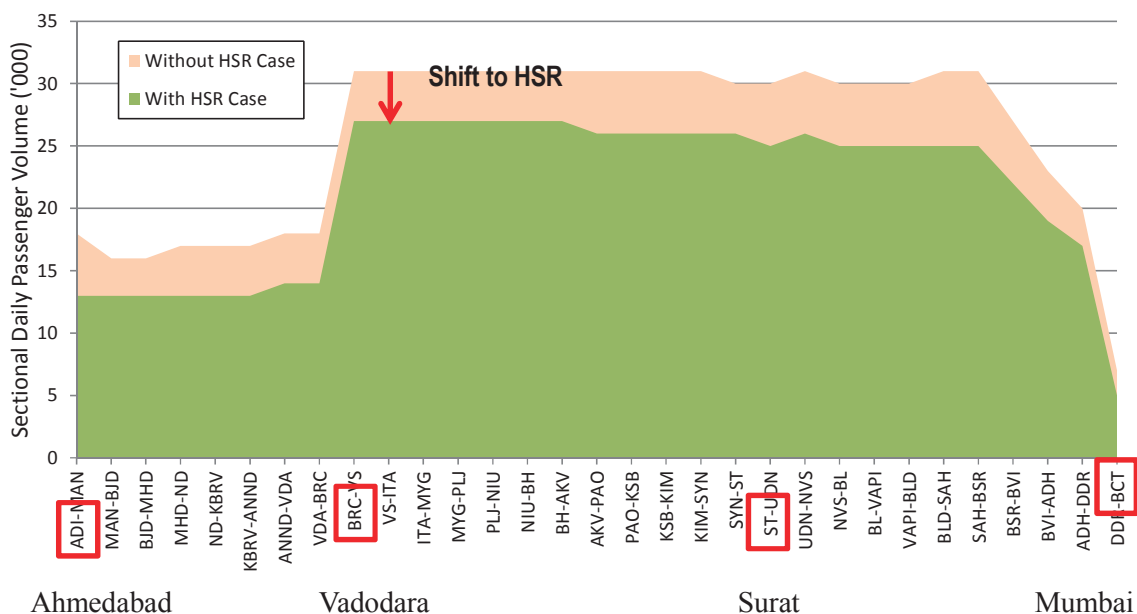

Figure 5.3-25 Sectional Daily Passenger Volume for Existing Railway in 2023  
Ahmedabad-Mumbai Section<sup>12</sup>  
(1A\*1.5, With Sabarmati St. Case)

<sup>12</sup> ADI:Ahmedabad St., BRC: Vadodara St., ST:Surat St., BCT:Mumbai Central St.

## 5.4 Study for Multi-class Fare System

To conduct the economic and the financial analysis in this study, HSR fare is assumed as the fare which is estimated to maximize the total fare-box for HSR, namely, 1.5 times of 1A class fare for railway. The modal share is estimated by the modal split model which was developed based on the willingness to pay survey along the target corridor. In the model, travel fare and travel time are assumed as crucial indicators to decide the modal choice. It should be mentioned that the other factors such as seat availability, comfortability, safety, punctuality and image of transport, may affect the modal choice of each person. However, these factors are difficult to forecast quantitatively.

Therefore, actual fare should be decided considering the service level and marketing strategy for other transportation mode and social aspect as well.

Following is the cross country study for seat class and discount ticket.

### 5.4.1 Cross Country Study for Fare Level by Seat Class

Table 5.4-1 shows the fare for HSR by seat class by country.

The ratio of 1st class ticket to 2nd / economy class ticket is 3.1-3.2 in China. The ratio in Russia is 2.0. The ratio in Taiwan, Korea, Japan, France and Turkey is about 1.3 – 1.8.

Table 5.4-1 HSR Fare by Seat Class by Country

Country	Origin	Destination	Distance (km)	A:Fare for 2nd /Economy Class (USD)	B:Fare for 1st/Business Class (USD)	Business/Economy Class Rate (B/A)
China	Beijing	Tiajin	120	8.86	28.19	3.18
		Jinan	406	29.97	N/A	N/A
		Xuzhou East	692	49.78	156.92	3.15
		Shanghai	1,318	89.09	281.61	3.16
		Nanjim	1,160	71.53	N/A	N/A
Turkey	Ankara	Eskisehir	245	11.84	16.58	1.40
		Konya	290	11.84	16.58	1.40
Taiwan	Taipei	Taichung	160	25.40	36.35	1.43
		Zuoying	340	54.12	71.05	1.31
Korea	Seoul	Daejeon	160	20.90	29.26	1.40
		Pusan	409	50.64	70.87	1.40
France	Paris	Lille	251	45.95	82.84	1.80
		Lyon	409	66.51	96.75	1.45
Japan	Tokyo	Nagoya	366	105.79	142.61	1.35
		Shin-osaka	553	138.43	186.81	1.35
Russia	Moskaw	Sankt-Peterburg	650	90	182.20	2.02

Source: JICA Study Team

#### 5.4.2 Discount Ticket

To reduce the ridership risk and induce the traffic demand, discount system is introduced to HSR in other countries as well as other transportation mode in India. Following discount systems are major examples.

- Discount for Early Booking: Passenger can acquire discount for ticket if they book the ticket in advance.
- Seasonal Discount: If passengers buy ticket in off-season, discount is given. Contrary, ticket price increases in high season.
- Weekend Discount: For the busy section for business travelers, weekend discount is applied to induce the trips for other purpose.
- Discount for Round Trip Ticket: The traveler can get discount for return ticket, if they book the ticket with the ticket for outward.
- Online Booking Discount: Passenger gets the discount if they book online system.