

RECORD OF DISCUSSIONS
ON
PROJECT ON REGIONAL DEVELOPMENT PLANNING OF THE
SOUTHERN REGION
IN
THE REPUBLIC OF TUNISIA
AGREED UPON BETWEEN
MINISTRY OF REGIONAL DEVELOPMENT AND PLANNING
AND
SOUTH DEVELOPMENT OFFICE
AND
JAPAN INTERNATIONAL COOPERATION AGENCY

Tunis, 9th October, 2012

M. Furuichi

Masahiko Furuichi
Team Leader

Japan International Cooperation
Agency



Sami Larba
Director General

Regional Development Department
Ministry of Regional Development and
Planning



Mohamed Riahi
Director General

South Development Office
Ministry of Regional Development and
Planning

In response to the official request of the Government of Tunisia (hereinafter referred to as "GOT") to the Government of Japan, the Japan International Cooperation Agency (hereinafter referred to as "JICA") held a series of discussions with Ministry of Regional Development and Planning of GOT (hereinafter referred to as "MRDP"), South Development Office of GOT (hereinafter referred to as "ODS") and relevant organizations to develop a detailed plan of the Project on Regional Development Planning of the Southern Region in the Republic of Tunisia (hereinafter referred to as "the Project").

Both parties agreed the details of the Project and the main points discussed as described in the Appendix 1 and the Appendix 2 respectively.

Both parties also agreed that ODS, the counterpart to JICA, will be responsible for the implementation of the Project in cooperation with JICA, coordinate with MRDP and other relevant organizations and ensure that the self-reliant operation of the Project is sustained during and after the implementation period in order to contribute toward social and economic development of the Republic of Tunisia.

The effectiveness of the Record of Discussions is subject to the approval of JICA.

Appendix 1: Project Description
Appendix 2: Main Points Discussed



PROJECT DESCRIPTION

I. BACKGROUND

One of the major challenges of public authorities in Tunisia is correcting regional imbalances through promoting a dynamic convergence across the regions. Integrated regional development is the best way to achieve such challenges. It aims at raising the socio-economic and environmental potential and the competitiveness of the economic players and regions so that the standard of living and quality of life may rise for their populations. Achieving the transition to the liberal and participatory approach society after Tunisian revolution in 2011, the integrated regional development is required to be truly fair, viable and socially and ecologically responsible possible. The integrated regional development is essential to help brake depopulation of regions lagging behind, and stop desertification, one of the major problems in climatic change.

MRDP is responsible in strategic orientation of relevant inter-ministry partnership, particularly with the ministries in charge of agriculture, industry, commerce, transport, tourism, equipment and information and communications technologies, which are vital in supporting integrated regional development. Inadequate public-private partnership, less competitive domestic industries and less attractive logistical and investment environment have resulted in insufficient availability of qualified personnel, a dynamic and effective distribution system and an attractive living environment. The southern region is a typical region lagging behind which is covered almost by desert except coastal area. The main industries of the region are only agricultural crops (olive and its products etc.) and mining (phosphate fertilizer etc.).

Besides, Tunisia received approximately one (1) million refugees by Libyan revolution, most of which had evacuated and stayed in the communities of the region as an economic burden, and returned within half a year. If the economic situation of the region remained un-recovered, however, the region would accelerate widened regional imbalance and job-less society.

Thus, the formulation of integrated regional development plan through participatory approach to solve the above situations is needed especially in the southern region. At the same time, capacity of planning and administrative management for participatory approach needs to be developed as well.

This is a component of "the Program on Regional Economic Promotion" in line with JICA's Assistance Program.

II. OUTLINE OF THE PROJECT

1. Title of the Project

"Project on Regional Development Planning of the Southern Region in the Republic of Tunisia"

The official French title of the Project is as follows;

"Projet de Planification pour le Développement Régional du Sud de la Tunisie"

2. Overall Goal

The institutional capacity of MRDP and ODS on regional development planning will be developed.

3. Expected Goals which will be attained after the Project Completion

(1) Goal of the Proposed Plan

The regional development plan will be developed through public consultation as a participatory approach.

(2) Goal which will be attained by utilizing the Proposed Plan

(a) Sustainable regional development is promoted to reduce regional disparity by utilizing available resources and advantages of the southern region.

(b) Living environment and quality are improved in the southern region.

4. Outputs

- (1) Formulation of regional development strategy for the period 2014 to 2033,
- (2) Formulation of regional development plan for the period 2014 to 2023, and
- (3) Capacity development of planning and administrative management for participatory approach to Tunisian counterpart through the Project.

5. Activities

- (1) Review of the existing development policies and plans, development projects, studies, both public and private investments, and socio-economic data,
- (2) Formulation of the future vision and the basic development concept,
- (3) Formulation of the development strategy,
- (4) Formulation of the regional development plan,
- (5) Set of priorities on target sectors,
- (6) Formulation of implementation action plans, and
- (7) Technology transfer of development planning and capacity development of human resources.

6. Input

(1) Input by JICA

Dispatch of experts

- (a) Regional Development
- (b) Industrial Promotion
- (c) Trade Promotion/Marketing
- (d) Agro/Fishery-Processing
- (e) Tourism
- (f) Transport
- (g) Water Supply/Sewage System
- (h) Energy
- (i) Participatory Approach
- (j) Institutional System
- (k) Human Resource Development
- (l) Environmental and Social Considerations

Input other than indicated above will be determined through mutual consultations between JICA and ODS during the implementation of the Project, as necessary.

Training in Japan

JICA will organize training courses on regional development planning in Japan, which will be held during the Project period. Staff of MRDP and ODS will participate in the training course.

(2) Input by ODS

ODS will take necessary measures to provide at its own expense:

- (a) Services of ODS's counterpart personnel and administrative personnel as referred to in II-7,
- (b) Suitable office space with necessary equipment,
- (c) Information as well as support in obtaining medical service,
- (d) Credentials or identification cards,
- (e) Available data (including the existing digital/analog maps and photographs) and information related to the Project,
- (f) Running expenses necessary for the implementation of the Project thereof, and
- (g) Arrangement of workshops and presentation of the progress of the project in workshops

7. Implementation Structure

The Project organization chart is given in the Annex 1. The roles and assignments of relevant organizations are as follows:

(1) Responsible Agency

MRDP will supervise the Project.

(2) Implementation Agency

ODS will be responsible for smooth implementation of the Project.

(3) JICA Experts

The JICA experts will give necessary technical guidance, advice and recommendations to ODS on any matters pertaining to the implementation of the Project.

(4) Steering Committee and Working Group

Steering Committee (hereinafter referred to as "S/C") and Working Group (hereinafter referred to as "W/G") will be established in order to facilitate inter-organizational coordination. S/C will be held when the JICA mission submits the reports and/or whenever deems it necessary for decision making regarding the Project. A list of proposed members of S/C is shown in the Annex 2. W/G will be established and function as daily-work basis to correspond to the JICA mission. A list of proposed members of W/G is shown in the Annex 3.



8. Project Site(s) and Beneficiaries

The Project will cover the area of the southern region in the Republic of Tunisia, namely Gafsa Governorate, Gabes Governorate, Tozeur Governorate, Kebili Governorate, Medenine Governorate, and Tataouine Governorate.

However, the field survey by JICA experts will be conducted under the JICA security policy.

The direct beneficiary of the Project will be 130 staff of ODS and the indirect beneficiary of the Project will be around 1.6 million people in the southern region in the Republic of Tunisia.

9. Duration

The Project will be carried out for approximately 20 (twenty) months from the start of the first training in Japan.

Month	1	2	3	4	5	6	7	8	9	10	11	12	13	14	15	16	17	18	19	20
Project	■																			
S/C			▲					▲					▲						▲	
Report			▲					▲					▲						▲	▲
			IcR					PR					ItR						DfR	FR

Notes: S/C: Steering Committee, IcR: Inception Report, PR: Progress Report, ItR: Interim Report, DfR: Draft Final Report, FR: Final Report

10. Reports

JICA will prepare and submit the following reports in French to ODS.

- (1) 30 copies of Inception Report at the commencement of the work period in the Republic of Tunisia
- (2) 30 copies of Progress Report at the time about 8 months after the commencement of the work period in the Republic of Tunisia
- (3) 30 copies of Interim Report at the time of 13 months after the commencement of the work period in the Republic of Tunisia
- (4) 30 copies of Draft Final Report at the end of the work period in the Republic of Tunisia
- (5) 30 copies of Final Report within one (1) month after the receipt of the comments on the Draft Final Report

11. Environmental and Social Considerations

- (1) MRDP and ODS agreed to abide by 'JICA Guidelines for Environmental and Social Considerations' in order to ensure that appropriate considerations are made for the environmental and social impacts of the Project
- (2) MRDP, ODS and JICA agreed to conduct the strategic environment assessment following to the TOR shown in Annex 4.
- (3) MRDP, ODS and JICA agreed that JICA will disclose the R/D and the result of Detailed Planning Survey on its web site.

mof

[Handwritten signatures]

III. UNDERTAKINGS OF GOT AND ODS

1. GOT and ODS will take necessary measures:

- (1) To ensure that the technologies and knowledge acquired by the Republic of Tunisia nationals as a result of Japanese technical cooperation contribute to the economic and social development of the Republic of Tunisia, and that the knowledge and experience acquired by the personnel of the Republic of Tunisia from technical training as well as the equipment provided by JICA are utilized effectively in the implementation of the Project;
- (2) To grant privileges, exemptions and benefits to the members of the JICA missions, which are no less favorable than those granted to the experts and the members of the missions and their families of third countries or international organizations performing similar missions in the Republic of Tunisia; and
- (3) To provide security-related information as well as measures to ensure the safety of the members of the JICA missions.

Other privileges, exemptions and benefits shall be in accordance with the "Note Verbale" (n° 47188) exchanged between GOJ and GOT on July 9, 1988.

2. ODS will bear claims, if any arises, against the members of the JICA missions resulting from, occurring in the course of, or otherwise connected with, the discharge of their duties in the implementation of the Project, except when such claims arise from gross negligence or willful misconduct on the part of the members of the JICA missions.

IV. EVALUATION

JICA will conduct the following evaluations and surveys to mainly verify sustainability and impact of the Project and draw lessons. The ODS is required to provide necessary support for them.

1. Ex-post evaluation three (3) years after the project completion, in principle
2. Follow-up surveys on necessity basis

V. PROMOTION OF PUBLIC SUPPORT

For the purpose of promoting support for the Project, ODS will take appropriate measures to make the Project widely known to the people of Tunisia.

VI. MUTUAL CONSULTATION

JICA, MRDP and ODS will consult each other whenever any major issues arise in the course of Project implementation.



VII. AMENDMENTS

The Record of Discussions may be amended by the Minutes of Meetings between JICA, MRDP and ODS.

The minutes of meetings will be signed by authorized persons of each side who may be different from the signers of the record of discussions.

- Annex 1 Project Organization Chart
- Annex 2 A List of Proposed Members of Steering Committee
- Annex 3 A List of Proposed Members of Working Group
- Annex 4 TOR of Environmental and Social Considerations

anf

Project Organization Chart

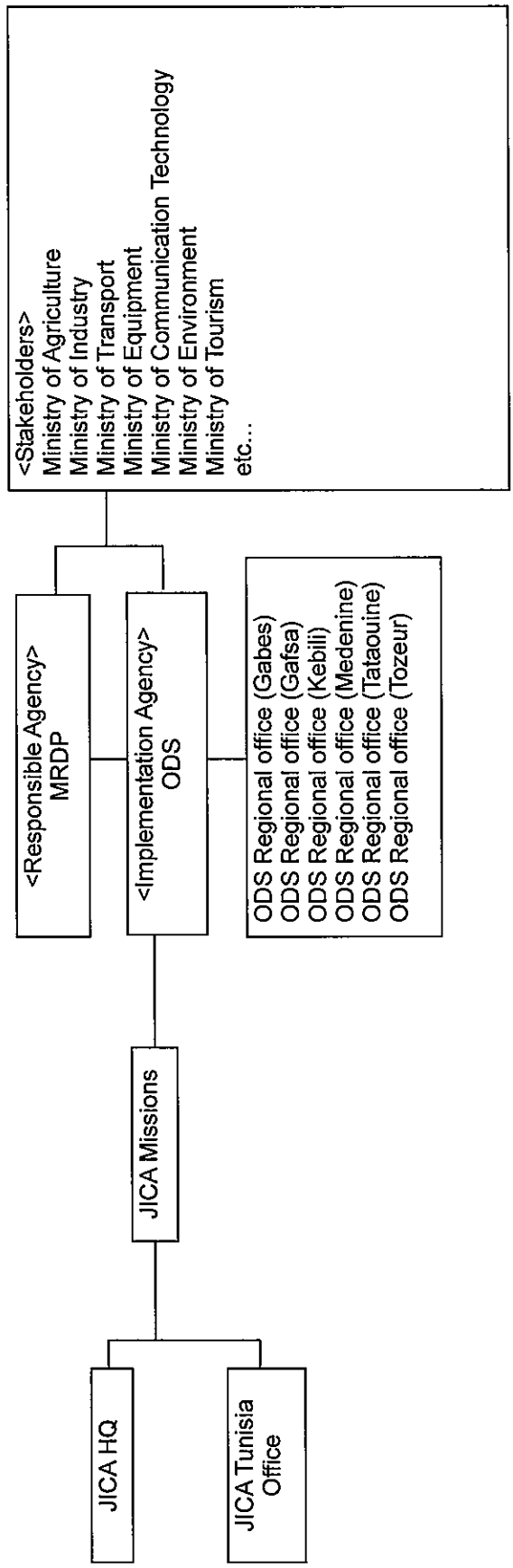

A List of Proposed Members of Steering Committee

1. Function

The Steering Committee will be held when the JICA missions submit the reports and/or whenever the necessity arises in order to fulfill the following functions;

- (1) To monitor and supervise the entire project:
- (2) To discuss and approve the reports;
- (3) To coordinate among the relevant organizations; and
- (4) To review and exchange views on major issues arising from or in connection with the Project.

2. Members

- a. Chair :Director General, Regional Development, MRDP
- b. Co-chair :Director General, ODS
- c. Members :Director General, Infrastructure, MRDP
:Director General, Productive Sector, MRDP
:Director General, Prevision, MRDP
:Director, Regional Development Department, MRDP
:Leader, the JICA expert team

The chair may invite necessary representatives of relevant ministries other than indicated above.

A List of Proposed Members of Working Group

1. Function

The Working Group will be held at least bimonthly and/or whenever the necessity arises in order to fulfill the following functions;

- (1) To carry out surveys and analyze the current situation of the Project area;
- (2) To prepare reports for presentation to the S/C;
- (3) To examine and analyze the technical aspects of the Reports;
- (4) To monitor and evaluate the Project;
- (5) To coordinate the Project with stakeholders; and
- (6) To deal with any issues instructed to consult by S/C.

2. Members

- a. Chair :Director General, ODS
- b. Co-chair :Leader, the JICA missions
- c. Members :Director, Common Interest Management Department
:Director, Promotion and Private Investment Department
:Director, Planning and Statistics Department
:Director, Assistance of Development and Evaluation Department
:Director, Coordination Department
:Director, Information Division
:Director, Regional Development Department, Gabes
:Director, Regional Development Department, Gafsa
:Director, Regional Development Department, Kebili
:Director, Regional Development Department, Medenine
:Director, Regional Development Department, Tataouine
:Director, Regional Development Department, Tozeur

Members of relevant ministries' regional offices other than indicated above will be determined through mutual consultations between JICA and ODS during the Project, as necessary.

TOR of Environmental and Social Considerations

The project should include Terms of Reference (TOR) for Environmental and Social Considerations in line with the JICA Guidelines as the bellows;

1. Consideration of alternatives for achieving the goals of the Project,
2. Consideration of contents of the developed policy and plans,
3. Implementation of scoping,
4. Confirmation of environment and social situation as the base line,
5. Confirmation of system and regulation for environment and social consideration,
6. Forecast of the environmental impact,
7. Evaluation of the environmental impact and examination of alternatives,
8. Confirmation of mitigation,
9. Confirmation of monitoring method, and
10. Assistance of stakeholder meetings.

mf



MAIN POINTS DISCUSSED

1. Target year of a strategy and a development plan
The Tunisian side explained that there was the 11th national decade plan (2007-2016¹) as the current national development plan, and duration of a developed strategy should be the next twenty (20) years after the completion of the project and duration of a regional development plan should be the next ten (10) years after that.
Both sides agreed that the target year of the Regional Development Strategy developed in the Project was 2033 and that of the Regional Development Plan was 2023 respectively.
2. Coverage of the Regional Development Plan
Both sides agreed that the Regional Development Plan would target at the southern region as a whole area. Therefore, the development plan of each governorate would be out of scope.
Both sides also agreed that the Regional Development Plan would describe future vision of the southern region and actions for achieving the vision, and exclude investment project plans, detailed development project plans and feasibility studies of projects.
3. Process of public consultation
Tunisian side explained that there was a regional development committee in each governorate consisting of representatives of politician, labor union, economic association, professionals and so on, and that a regional development plan of each governorate should be consulted with the regional development committee in the course of development as citizen participation procedures.
Both sides confirmed that the regional development plan targeting at the whole southern area including six (6) governorates, not each governorate and that there was no proper committee covering this area.
Therefore, both sides agreed that ODS should organize workshops three (3) times during the Project as a public consultation process, and that each workshop would be held in the timing of the Inception Report (ICR), Interim Report (ITR), and Draft Final Report (DFR), and that representatives of each regional development committee would be invited in workshops. JICA experts should fully support ODS to organize and proceed workshops. JICA should bear expenses necessary for workshops.
4. Management of workshops
Both sides agreed that three (3) workshops should be managed by ODS and staff of ODS should make presentations in the workshops with assistance of JICA experts.
Both sides agreed that member of workshops would be carefully selected by

¹ Note d'orientation du XI^{ème} Plan et de la décennie 2007-2016

ODS and informed to JICA Tunisia office in written by 31st January, 2013.

5. Capacity development of MRDP and ODS
Tunisian side requested that capacity development of MRDP and ODS staff should be included in the Project activities.
Both sides agreed that on-the-job training though daily works with JICA experts and training courses in Japan should be carried out in the Project.
6. Field of experts
Tunisian side requested to add an expert on the field of information and communications technology (ICT) in terms of one of possibilities of industry promotion.
Japanese side explained that situation of ICT would be surveyed and the results would be analyzed in the Project.
Both sides agreed the field of industry promotion should cover the field of ICT.
7. Communication with counterparts
Both sides agreed that JICA consultants should closely communicate with ODS about their schedule in order for ODS to organize relevant organizations and take his ownership among relevant organizations.
8. Past JICA activities to be taken into consideration
JICA implemented several activities such as One Village One Product (OVOP) by a senior volunteer and the Project of Grass-roots Grant Aid in the southern region. Both sides agreed that the Project will take the past JICA activities into consideration.
9. Provision of office space in MRDP
Both sides agreed that MRDP provided suitable office space with necessary equipment for JICA experts.

END

anf

