

2 - 1

Multiplication and Division of Fractions

Multiplying a Fraction by a Whole Number (1)

Example

One dL of paint can cover a $\frac{2}{7}$ m² area. How much area can 3 dL of paint cover?

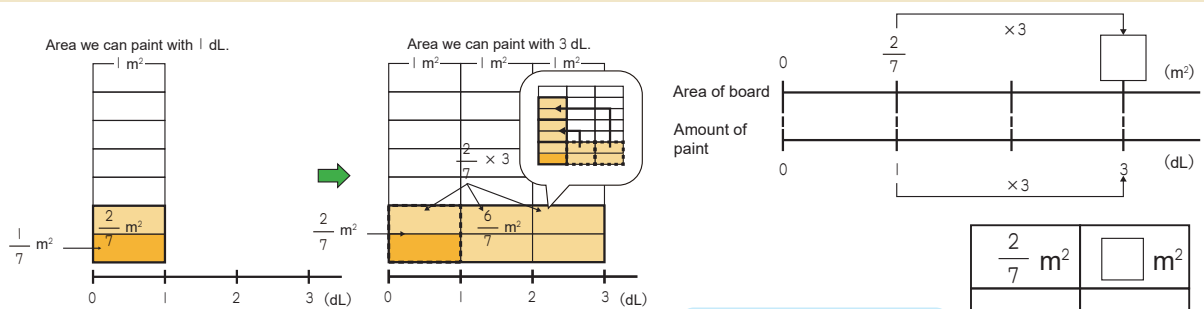

Math sentence

$$\frac{2}{7} \times 3 = \frac{2 \times 3}{7} = \frac{6}{7}$$

There are six $(2 \times 3) \frac{1}{7}$ s.

Answer

$$\frac{6}{7} \text{ m}^2$$

To multiply a fraction by a whole number, multiply the numerator by the whole number.

$$\frac{\bullet}{\blacksquare} \times \blacktriangle = \frac{\bullet \times \blacktriangle}{\blacksquare}$$

1 $\frac{2}{9}$ kg of flour is needed to make one cake. How much flour is needed to make 4 cakes?

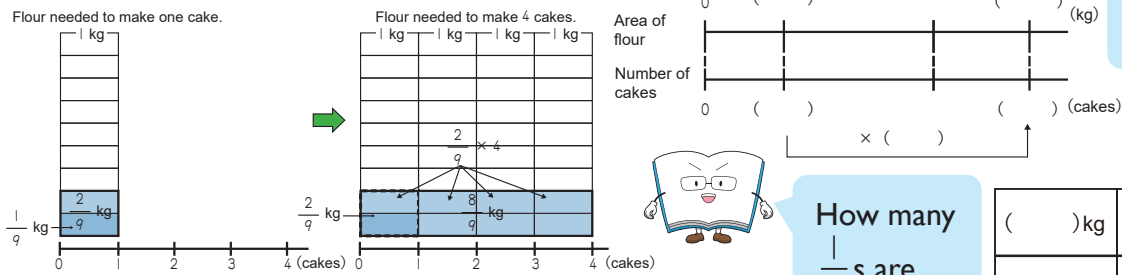

Math sentence

How many $\frac{1}{9}$ s are there?

Answer

2 Calculate the following multiplication problems. Leave the answer as improper fractions.

1 $\frac{3}{5} \times 2 = \frac{\square}{\square} \times \frac{\square}{\square} = \frac{\square}{\square}$

2 $\frac{3}{10} \times 3 = \frac{\square}{\square} \times \frac{\square}{\square} = \frac{\square}{\square}$

3 $\frac{4}{7} \times 5$

4 $\frac{3}{5} \times 6$

5 $\frac{1}{3} \times 7$

6 $\frac{5}{8} \times 9$

2 - 2

Multiplication and Division of Fractions

Multiplying a Fraction by a Whole Number (2)

Example 1 Calculate $\frac{7}{12} \times 4$



Student A

$$\frac{7}{12} \times 4 = \frac{7 \times 4}{12} = \frac{28}{12} = \frac{7}{3}$$

He simplified the answer at the end.



Student B

$$\frac{7}{12} \times 4 = \frac{7 \times \cancel{4}^1}{\cancel{12}_3} = \frac{7}{3}$$

She simplified it in the middle of calculation.

Student A simplified the product after calculating it (calculated twice), but Student B simplified in the middle of calculation (calculated once). The way of Student B is easier to calculate. This is the ingenuity of calculation.



1 Calculate the following multiplication problems. Simplify when possible. Leave the answer as improper fractions.

① $\frac{5}{6} \times 3 = \frac{\square}{\square} \times \frac{\square}{\square} = \frac{\square}{\square}$

② $\frac{5}{8} \times 4 = \frac{\square}{\square} \times \frac{\square}{\square} = \frac{\square}{\square}$

③ $\frac{4}{15} \times 3$

④ $\frac{11}{12} \times 18$

⑤ $\frac{3}{8} \times 20$

⑥ $\frac{13}{6} \times 12$

Example 2 Calculate $1\frac{2}{3} \times 4$

$$1\frac{2}{3} \times 4 = \frac{5}{3} \times 4 = \frac{5 \times 4}{3} = \frac{20}{3} \text{ or } 6\frac{2}{3}$$

We can change a mixed number to an improper fraction, and then calculate it by using the formula shown in the previous page.

Mixed numbers make it easy to imagine the size of numbers, but we convert mixed numbers to improper fractions when calculating.



2 Calculate the following multiplication problems. Simplify when possible.

① $1\frac{5}{6} \times 9 = \frac{\square}{\square} \times \square = \frac{\square}{\square} \times \frac{\square}{\square} = \frac{\square}{\square} \text{ or } \frac{\square}{\square}$

② $1\frac{5}{8} \times 6 = \frac{\square}{\square} \times \square = \frac{\square}{\square} \times \frac{\square}{\square} = \frac{\square}{\square} \text{ or } \frac{\square}{\square}$

③ $3\frac{3}{4} \times 2$

④ $2\frac{2}{9} \times 6$

2 - 3

Multiplication and Division of Fractions

Dividing a Fraction by a Whole Number (1)

Example

Two dL of paint can cover $\frac{4}{7} \text{ m}^2$. How much area can 1 dL of paint cover?

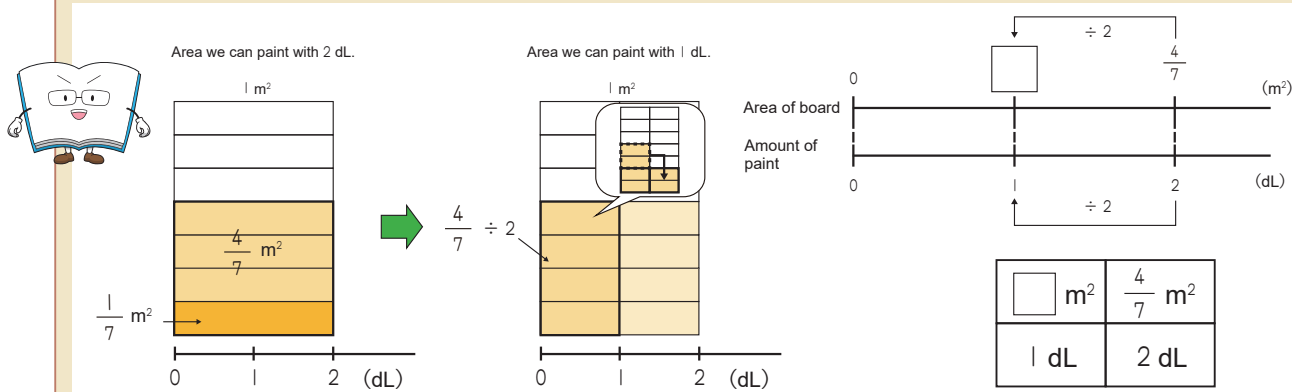

Math sentence

$$\frac{4}{7} \div 2 = \frac{4 \div 2}{7} = \frac{2}{7}$$

Answer $\frac{2}{7} \text{ m}^2$

1 $\frac{8}{9}$ L of oil can run a machine for 4 hours. How many L of oil is needed to run the machine for 1 hour?

Complete the number line diagram and table.

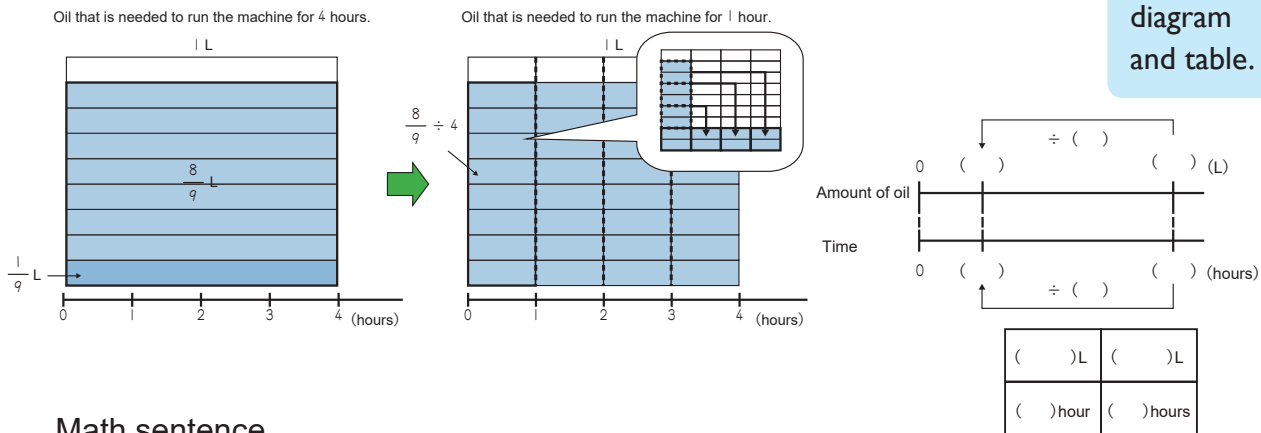

Math sentence

Answer _____

2 Calculate the following division problems.

1 $\frac{9}{4} \div 3$

2 $\frac{4}{5} \div 2$

3 $\frac{6}{7} \div 3$

4 $\frac{12}{5} \div 6$

5 $\frac{15}{8} \div 3$

6 $\frac{20}{3} \div 5$

2 - 4

Multiplication and Division of Fractions

Dividing a Fraction by a Whole Number (2)

Example 1 Calculate $\frac{3}{5} \div 2$

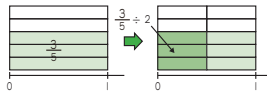

$$\frac{3}{5} \div 2 = \frac{3}{5 \times 2} = \frac{3}{10}$$

Three (3) is not divisible by 2 as the whole number. Therefore, we cannot do $\frac{3 \div 2}{5}$. How can we calculate this?



To divide a fraction by a whole number, multiply the fraction by the whole number's reciprocal. Remember, a whole number can be written as a fraction, $\blacktriangle = \frac{\blacktriangle}{1}$.

Its reciprocal is $\frac{1}{\blacktriangle}$.

$$\frac{\bullet}{\blacksquare} \div \blacktriangle = \frac{\bullet}{\blacksquare} \times \frac{1}{\blacktriangle}$$

1 Calculate the following division problems. Simplify when possible.

① $\frac{4}{5} \div 3 = \frac{\square}{\square} \times \frac{\square}{\square} = \frac{\square}{\square}$

② $\frac{5}{6} \div 2 = \frac{\square}{\square} \times \frac{\square}{\square} = \frac{\square}{\square}$

③ $\frac{3}{8} \div 5$

④ $\frac{4}{7} \div 3$

⑤ $\frac{10}{3} \div 4$

⑥ $\frac{12}{5} \div 15$

Example 2 Calculate $1\frac{3}{7} \div 5$

$$1\frac{3}{7} \div 5 = \frac{10}{7} \div 5 = \frac{10}{7 \times 5} = \frac{2}{7}$$

When dividing a mixed number by a whole number, convert the mixed number to an improper fraction first. Multiply the improper fraction by the whole number's reciprocal.

2 Calculate the following division problems. Simplify when possible.

① $1\frac{4}{7} \div 6 = \frac{\square}{\square} \div \square = \frac{\square}{\square} \times \frac{\square}{\square} = \frac{\square}{\square}$

② $2\frac{2}{3} \div 5 = \frac{\square}{\square} \div \square = \frac{\square}{\square} \times \frac{\square}{\square} = \frac{\square}{\square}$

③ $1\frac{3}{4} \div 2$

④ $2\frac{3}{5} \div 6$

⑤ $3\frac{1}{9} \div 4$

⑥ $1\frac{1}{6} \div 7$

2 - 5

Multiplication and Division of Fractions

Review

1 Calculate the following multiplication problems. Simplify when possible.

1 $\frac{5}{8} \times 3$

2 $\frac{3}{4} \times 9$

3 $\frac{5}{12} \times 3$

4 $\frac{1}{6} \times 10$

5 $1\frac{5}{6} \times 4$

6 $3\frac{2}{5} \times 10$

2 Calculate the following division problems. Simplify when possible.

1 $\frac{9}{8} \div 3$

2 $\frac{32}{7} \div 8$

3 $\frac{2}{9} \div 6$

4 $\frac{6}{7} \div 4$

5 $3\frac{5}{9} \div 8$

6 $2\frac{2}{5} \div 6$

3 Write the math sentence for the following word problems and calculate. Simplify when possible.

Complete the number line diagrams and tables.



1 $\frac{7}{12}$ kg of flour is needed to make one loaf of bread. How much flour is needed to make 3 loaves?

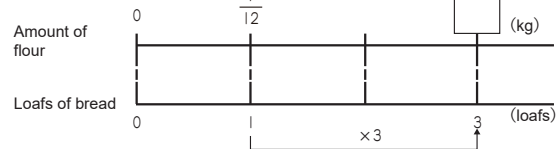
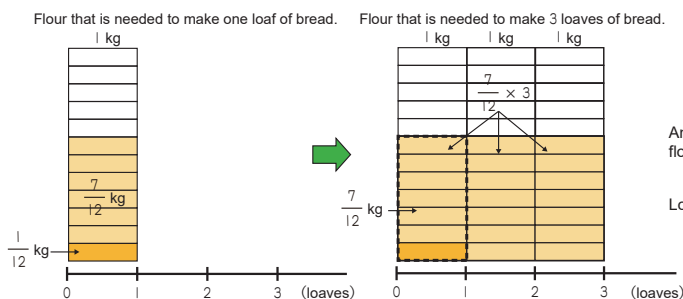

$\frac{7}{12}$ kg	<input type="text"/> kg
1 loaf	3 loaves

Math sentence

Answer

- 2 A 1 m wire weighs $\frac{2}{25}$ kg. How much will 5 m of this wire weigh?

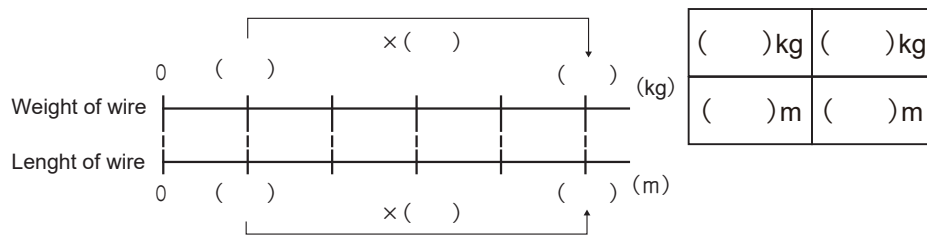
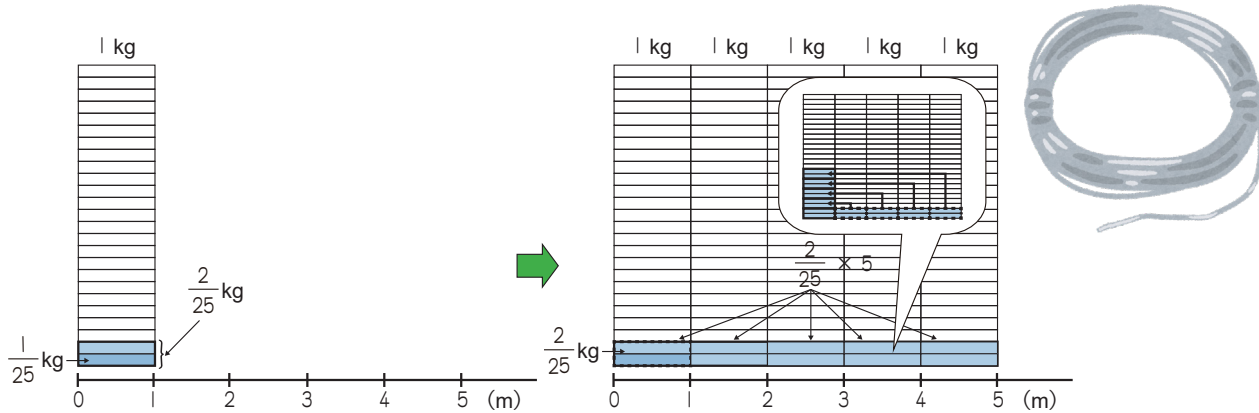

Math sentence

Answer _____

- 3 A pump can pump $\frac{12}{5}$ L of water in 3 minutes. How much water can it pump in 1 minute?

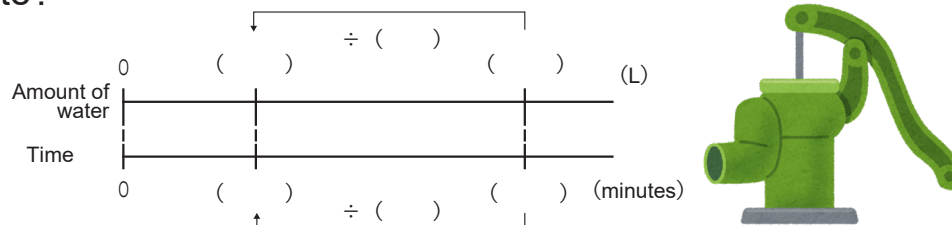

Math sentence

() L	() L
() minute	() minutes

Answer _____

- 4 $2\frac{2}{9}$ L of milk tea is shared equally among 4 people. How many L of tea will each person get?

Math sentence



Answer _____